

A (Ace) Servo for the Next Generation MINAS A4 Series



Advanced Gain Tuning

- Further Evolution in Real-Time Auto-Gain Tuning

Agile and Intelligent

- Improved Damping Control handles all types of machines, from low to high stiffness machines with simple but solid operation

Almighty

- Position Control, Velocity Control and Torque Control in one Driver supports multiplicity of application.

Amazingly slim size

- Another Evolution in down-sizing, by 25% in size (compared to A-series)

MINAS A4 Series

Contents

● Features	A4-1
● Details of Features	A4-3
● List of Specifications	A4-7
● Model Designation	A4-8
● Wiring Example	A4-9
● Table of Part Numbers and Options	A4-13
● Driver	
<Common Specifications>	A4-15
<Standard Wiring Example of Main Circuit>	A4-17
<Encoder Wiring Diagram>	A4-19
<Standard Wiring Example of Control Circuit Standard>	A4-20
<Table of Applicable Motors>	A4-21
<Dimensions>	A4-22
● Motor	
<Ratings/Specifications/Torque Characteristics>	A4-49
MAMA	A4-49
MSMD	A4-51
MQMA	A4-59
MSMA	A4-63
MDMA	A4-67
MGMA	A4-73
MFMA	A4-77
MHMA	A4-81
<Dimensions>	A4-87
MAMA	A4-87
MSMD	A4-88
MQMA	A4-90
MSMA	A4-91
MDMA	A4-93
MGMA	A4-96
MFMA	A4-99
MHMA	A4-101
● Motor with Gear Reducer/MSMD	
<General Specifications>	A4-105
<Ratings/Specifications>	A4-106
<Torque Characteristics>	A4-107
<Dimensions>	A4-108
● Conformity to CE and UL	A4-109
● IP65 Rating	A4-112
● Options	A4-113
● Recommended components	A4-127

Remarks :Instruction manual is available as an option as
 Japanese version : DV0P4200 and
 English version : DV0P4210

Details of Features

1. Further Adjustment-Free Operation

High-functionality Real-Time Auto-Gain Tuning

- Corresponds to even variation of load inertia. Offers real automatic gain tuning to low and high stiffness machines with a combination of an adaptive filter.
- Supports the vertical axis application where the load torque is different in rotational direction.
- Prevents the machine from over-traveling during automatic gain tuning with over-travel detecting function.
- Enables you to set and check while monitoring real-time automatic gain tuning conditions on the front panel.

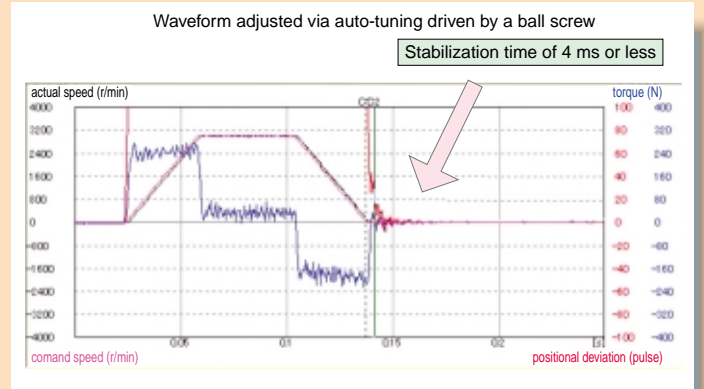

2. Further High-Speed and High-Response

Velocity response (bandwidth) of 1kHz

- Implementation of Instantaneous Velocity Observer realizes a detection of motor speed with higher speed and higher resolution.

*) In case of high stiffness machine

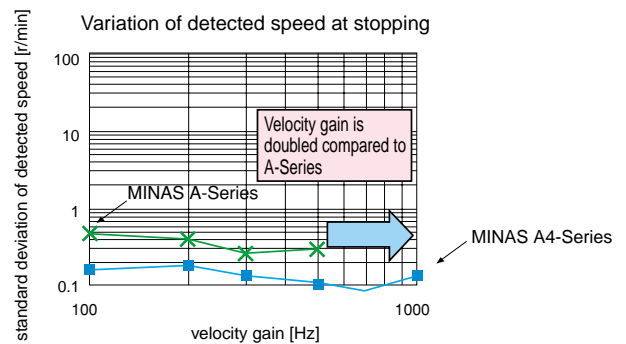
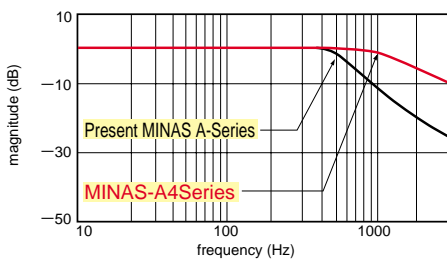

High-functionality Real-Time Auto-Gain Tuning

- Supports the low stiffness machine of belt-driven and the high stiffness machine of short stroke ball screw driven, and enables to realize high-speed positioning with high-functionality real-time auto-gain tuning.

3. Further Reduction of Vibration

Adaptive filter

- Makes the notch filter frequency automatically follow the machine resonance frequency.
- Suppression of "Judder" noise of the machine can be expected which is caused by variation of the machines or resonance frequency due to aging.

2-channel notch filters

- 2-channel notch filters are equipped in the driver independent from adaptive filter.
- You can set up both frequency and width for each of 2 filters, and set up frequency in unit of 1Hz.
- Suppression of "Judder" noise of the machine which has multiple resonance points can be expected

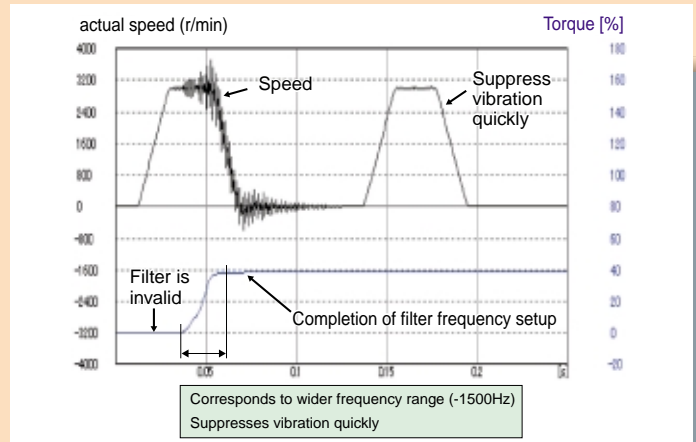

Effect of notch filter

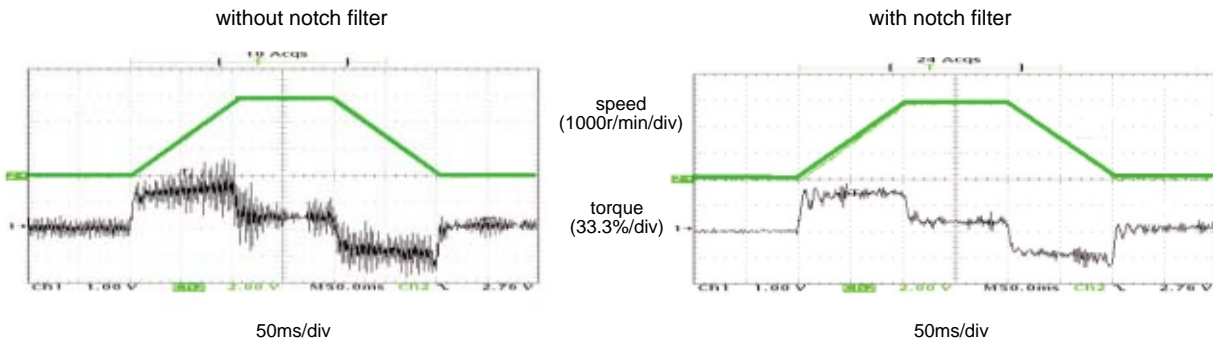

Damping control

- 2-channel damping filters are equipped in this driver. You can suppress vibration occurring at both starting and stopping in low stiffness machine, by manually setting up vibration frequency in 0.1Hz unit.
- You can also switch the vibration frequency set by 2-channel with rotating direction or with an external input to correspond to the variation of vibration frequency caused by the machine position.
- Easy setup with entry of only frequency and filter value. Improper setup values do not result in unstable operation



4. Further Flexibility and Multiplicity

Setup support with substantial monitoring function

- Faster communication speed of RS232/RS485 (Max.57600bps) establishes an easy and comfortable operating condition for setup support software, "PANATERM[®]".
- Displays the factors of no-motor run and helps you to analyze the causes of troubles.
- You can set up the panel operation lock to inhibit the operation from the front panel, thus enables you to prevent miss-operation such as unintentional change of parameters.

*Note) Refer to page "F4" for setup support software.

Command control modes

- Offers you "Position", "Velocity (including internal 8-speed)" and "Torque" command control modes
- You can set up any one of the command control modes, or selectable two command control mode with parameter.
- You can set up any command control mode depending on your application.

Monitoring function with front panel

- LED display and analog monitor terminals are installed in the front panel.
- Displays "Motor speed", "Motor torque" Position deviation", "Motor load factor" and "Regeneration load factor" on LED.
- You can monitor "Motor speed", "Motor torque" and "Position deviation" through analog monitor terminals.

Trial run (JOG)

- Features the function for trial (JOG) run through the front panel or console (option) without connecting to a host controller.
- You can shorten the machine setup time.

Full-closed control (High precision positioning)

- Features the full-closed control of position and velocity, using the signals from linear scale installed on the load side and high resolution encoder.

Note) Applicable external linear scales are as follows,

AT500 series by Mitutoyo (Resolution 0.05[μ m], max, speed 2[m/s])

ST771 series by Mitutoyo (Resolution 0.5[μ m], max, speed 2[m/s])

- Best suits to high precision machines.

Inrush current suppressing function

- Inrush current suppressing resistor is equipped in this driver, which prevents the circuit breaker shutdown of the power supply caused by inrush current at power-on.
- Prevents unintentional shutdown of the power supply circuit breaker in multi-axes application and does not give load to the power line.

Regeneration discharging function

- Discharges the regenerative energy with resistor, which energy is generated while stopping the load with large moment of inertia, or use in up-down operation, and is returned to the driver from the motor.
- No regeneration discharge resistor is built-in to Frame A driver (MADDT1105 type.) and Frame B driver (MBDDT2210 type.), and we recommend you to connect optional regenerative resistor.
- Regenerative resistor is built-in to Frame C to F drivers, however, connection of the optional regenerative resistor bring you further regenerative capability.

Built-in dynamic brake

- You can select the dynamic brake action which short the servo motor windings of U, V and W, at Servo-OFF, CW/CCW over-travel inhibition, power shutdown and trip.
- You can select the action sequence setup depending on the machine requirement.

Positioning pulse

- Corresponds up to 2Mpps of pulse input at positioning control.

Setup support software

- With the setup support software, "PANATERM[®]" via RS232/RS485 communication port, you can monitor the running status of the driver and set up parameters.
- You can read out the absolute position data of the motor with absolute encoder.

Wave-form graphic function

- With the setup support software, "PANATERM[®]", you can monitor the "Command speed", "Actual speed", "Torque", "Position deviation" and "Positioning complete signal".
 - Helps you to analyze the machine and shorten the setup time
- *Note) Refer to page "F4" for setup support software.

Torque limit value switching

- You can setup 2 torque limits and use them for tension control or press & hold control
- It is possible to apply it to bumping homing

SEMI F47 voltage sag immunity

- Features the function which complies to voltage sag immunity standard of SEMI F47 at no load or light load.
- Useful for semiconductor industry.

Notes)

- 1)Not applicable to single phase, 100V type.
- 2)Verify with the actual machine condition to F47, voltage sag immunity standard.

Frequency analyzing function

- You can confirm the response frequency characteristics of total machine mechanism including the servo motor with the setup support software, "PANATERM[®]"
 - Helps you to analyze the machine and shorten the setup time
- *Note) Refer to page "F4" for setup support software.









■Applicable overseas safety standards



Subject	Standard conformed		
Motor	IEC60034-1	IEC60034-5	Conforms to Low-Voltage Directives
	UL1004	CSA22.2 NO.100	
Motor and driver	EN50178	UL508C	Conforms to references by EMC Directives
	EN55011	Radio Disturbance Characteristics of Industrial, Scientific and Medical (ISM) Radio-Frequency Equipment	
	EN61000-6-2	Immunity for Industrial Environments	
	IEC61000-4-2	Electrostatic Discharge Immunity Test	
	IEC61000-4-3	Radio Frequency Electromagnetic Field Immunity Test	
	IEC61000-4-4	Electric High-Speed Transition Phenomenon/Burst Immunity Test	
	IEC61000-4-5	Lightening Surge Immunity Test	
	IEC61000-4-6	High Frequency Conduction Immunity Test	
	IEC61000-4-11	Instantaneous Outage Immunity Test	

- I E C : International Electrotechnical Commission
- E N : Europaischen Normen
- EMC : Electromagnetic Compatibility
- U L : Underwriters Laboratories
- CSA : Canadian Standards Association

List of Specifications

	Motor series	Rated output (kW)	Rated rotational speed (Max. speed) (r/min)	Rotary encoder		Brake	Gear	CE/UL	Enclosure	Features	Applications
				2500P/r incremental	17bit absolute/incremental	Holding	High precision				
Ultra low inertia	MAMA 	0.1-0.75 4 models 0.1, 0.2, 0.4 and 0.75	5000 (6000)	○	○	○	—	○	IP65 (Except shaft through hole and connector)	·Small capacity ·Suitable for the machines directly coupled with high speed ball screw and high stiffness and high repetitive application	·SMT machines ·Inserters ·High repetitive positioning application
Low inertia	MSMD 	0.05-0.75 5 models 0.05, 0.1, 0.2, 0.4 and 0.75	3000 (5000) *For 400W/100V and 750W 3000 (4500)	○	○	○	○	○	IP65 (Except shaft through hole and connector)	·Small capacity ·Suitable for all applications	·Inserters ·Belt driven machines ·Unloading robot
	MQMA 	0.1-0.4 3 models 0.1, 0.2, and 0.4	3000 (5000) *For 400W/100V 3000 (4500)	○	○	○	—	○	IP65 (Except shaft through hole and connector)	·Small capacity ·Suitable for flat type and low stiffness machines with belt driven	·SMT machines ·Inserters ·Belt driven machines ·Unloading robot
	MSMA 	1.0-5.0 6 models 1.0,1.5,2.0, 3.0,4.0 and 5.0	3000 (5000) *For 4kW and 5kW 3000 (4500)	○	○	○	—	○	IP65 (Except cannon plug/connector pins)	·Middle capacity ·Suitable for the machines directly coupled with ball screw and high stiffness and high repetitive application	·SMT machines ·Inserter ·Food machines
Middle inertia	MDMA 	1.0-7.5 6 models 1.0,1.5,2.0, 3.0,4.0,5.0 and 7.5	2000 (3000) *For 7.5kW 1500 (3000)	○	○	○	—	○	IP65 (Except cannon plug/connector pins)	·Middle capacity ·Suitable for low stiffness machines with belt driven	·Belt driven machines ·Conveyors ·Robots
	MGMA 	0.9-6.0 4 models 0.9,2.0, 3.0,4.5 and 6.0	1000 (2000)	○	○	○	—	○	IP65 (Except cannon plug/connector pins)	·Middle capacity ·Suitable for machines requiring low speed with high torque	·Belt driven machines ·Conveyors ·Robots
	MFMA 	0.4-4.5 4 models 0.4,1.5, 2.5 and 4.5	2000 (3000)	○	○	○	—	○	IP65 (Except cannon plug/connector pins)	·Middle capacity ·Flat type and suitable for machines with space limitation	·Robots ·Food machines
High inertia	MHMA 	0.5-7.5 7 models 0.5,1.0,1.5, 2.0,3.0,4.0, 5.0 and 7.5	2000 (3000) *For 7.5kW 1500 (3000)	○	○	○	—	○	IP65 (Except cannon plug/connector pins)	·Middle capacity ·Suitable for low stiffness machines with belt driven, and large load moment of inertia	·Belt driven machines ·Conveyors ·Robots

Motor is sharing with A4P series

Model Designation

■ Servo Motor

M S M D 5 A Z S 1 S * *

Symbol	Type
MAMA	Ultra low inertia (100W-750W)
MSMD	Low inertia (50W-750W)
MQMA	Low inertia (100W-400W)
MSMA	Low inertia (1.0kW-5.0kW)
MDMA	Middle inertia (1.0kW-7.5kW)
MGMA	Middle inertia (900W-6.0kW)
MFMA	Middle inertia (400W-4.5kW)
MHMA	High inertia (500W-7.5kW)

Special specifications

Design order
1 : Standard

Rotary encoder specifications

Symbol	Format	Pulse counts	Resolution	Wires
P	Incremental	2500P/r	10000	5
S	Absolute/ Incremental common	17bit	131072	7

Voltage specifications

Symbol	Specifications
1	100V
2	200V
Z	100V/200V common(50W only)

Motor rated output

Symbol	Rated output	Symbol	Rated output
5A	50W	15	1.5kW
01	100W	20	2.0kW
02	200W	25	2.5kW
04	400W	30	3.0kW
05	500W	40	4.0kW
08	750W	45	4.5kW
09	900W	50	5.0kW
10	1.0kW	60	6.0kW
		75	7.5kW

Motor structure

MSMD (standard stock), MQMA (build to order)

Symbol	Shaft		Holding brake		Oil seal	
	Round	Key-way, center tap	without	with	without	with*
A	●		●		●	
B	●			●	●	
S		●	●		●	
T		●		●	●	

*Motor with oil seal is manufactured by order.

MSMA, MDMA, MGMA, MFMA, MHMA

Symbol	Shaft		Holding brake		Oil seal	
	Round	Key-way	without	with	without	with
C	●		●			●
D	●			●		●
G		●	●			●
H		●		●		●

Products are standard stock items or build to order items. See index (page F31).

MAMA

Symbol	Shaft		Holding brake		Oil seal	
	Round	Key-way	without	with	without	with
A	●		●		●	
B	●			●	●	
E		●	●		●	
F		●		●	●	

Products are standard stock items or build to order items. See index (page F31).

See page, A4-49 for motor specifications

■ Motor with reduction gear

M S M D 0 1 1 P 3 1 N

Symbol	Type
MSMD	Low inertia (100W-750W)

Motor rated output

Symbol	Rated output
01	100W
02	200W
04	400W
08	750W

Voltage specifications

Symbol	Specifications
1	100V
2	200V

Rotary encoder specifications

Symbol	Format	Pulse counts	Resolution	Wires
P	Incremental	2500P/r	10000	5
S	Absolute/ Incremental common	17bit	131072	7

Gear reduction ration, gear type

Symbol	Gear reduction ratio	Motor output (W)				Gear type
		100	200	400	750	
1N	1 / 5	●	●	●	●	For high accuracy
2N	1 / 9	●	●	●	●	
3N	1 / 15	●	●	●	●	
4N	1 / 25	●	●	●	●	

Motor structure

Symbol	Shaft		Holding brake	
	Key-way	without	with	
3	●	●		
4	●		●	

See page, A4-105 for motor with gear reducer specifications

■ Servo Driver

M A D D T 1 2 0 5 * * *

Special specifications

Frame symbol

Symbol	Frame
MADD	A4 series, Frame A
MBDD	A4 series, Frame B
MCDD	A4 series, Frame C
MDDD	A4 series, Frame D
MEDD	A4 series, Frame E
MFDD	A4 series, Frame F
MGDD	A4 series, Frame G

Power device Max. current rating

Symbol	Power device Max. current rating
T1	1.0A
T2	1.5A
T3	3.0A
T5	5.0A
T7	7.5A
TA	1.0A
TB	1.5A
TC	3.0A

Supply voltage specifications

Symbol	Specifications
1	Single phase, 100V
2	Single phase, 200V
3	3-phase, 200V
5	Single/3-phase, 200V

Current detector current rating

Symbol	Current detector, current rating
05	5A
07	7.5A
10	1.0A
20	2.0A
30	3.0A
40	4.0A
64	6.4A
90	9.0A
A2	1.2A
B4	2.4A

See page, A4-15 for driver specifications

Wiring example

Driver Frame Type Symbol (Frame A, B, C, D)

For details, refer to the Instruction Manual.

●Wiring of main circuit

Circuit Breaker (NFB)

Protects the power lines.
Shuts off the circuit when overcurrent passes.

Noise Filter (NF)

Prevents external noise from the power lines.
And reduces an effect of the noise generated by the servo driver.

Magnetic Contactor (MC)

Turns on/off the main power of the servo driver.
Surge absorber to be used together with this.

Reactor (L)

Reduces harmonic current of the main power.

Pin RB1, RB2 and RB3...

- RB2 and RB3 to be kept shorted for normal operation.
- When the internal regenerative resistor capacity has shortage, disconnect between RB2 and RB3, then connect an external regenerative resistor between RB1 and RB2.

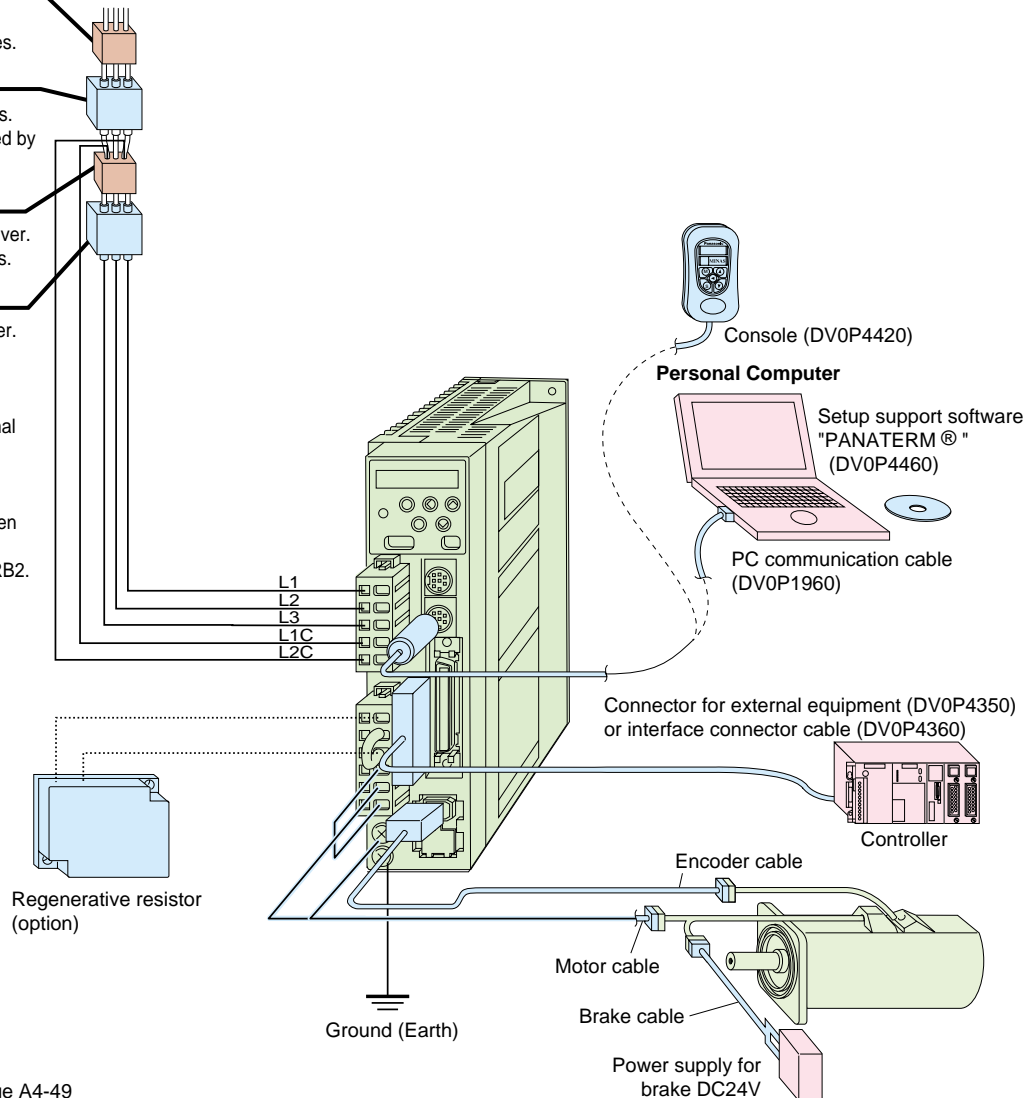

Motor to page A4-49

Driver to page A4-15

Option to page A4-113

Recommended equipments to page A4-12

Parts customer to prepare

Driver Frame Type Symbol (Frame E, F)

For details, refer to the Instruction Manual.

●Wiring of main circuit

Circuit Breaker (NFB)

Protects the power lines.
Shuts off the circuit when overcurrent passes.

Noise Filter (NF)

Prevents external noise from the power lines.
And reduces an effect of the noise generated by the servo driver.

Magnetic Contactor (MC)

Turns on/off the main power of the servo driver.
Surge absorber to be used together with this.

Reactor (L)

Reduces harmonic current of the main power.

P, B1 and B2...

- B1 and B2 to be kept shorted for normal operation.
- When the internal regenerative resistor capacity has shortage, disconnect between B1 and B2, then connect an external regenerative resistor between P and B2.

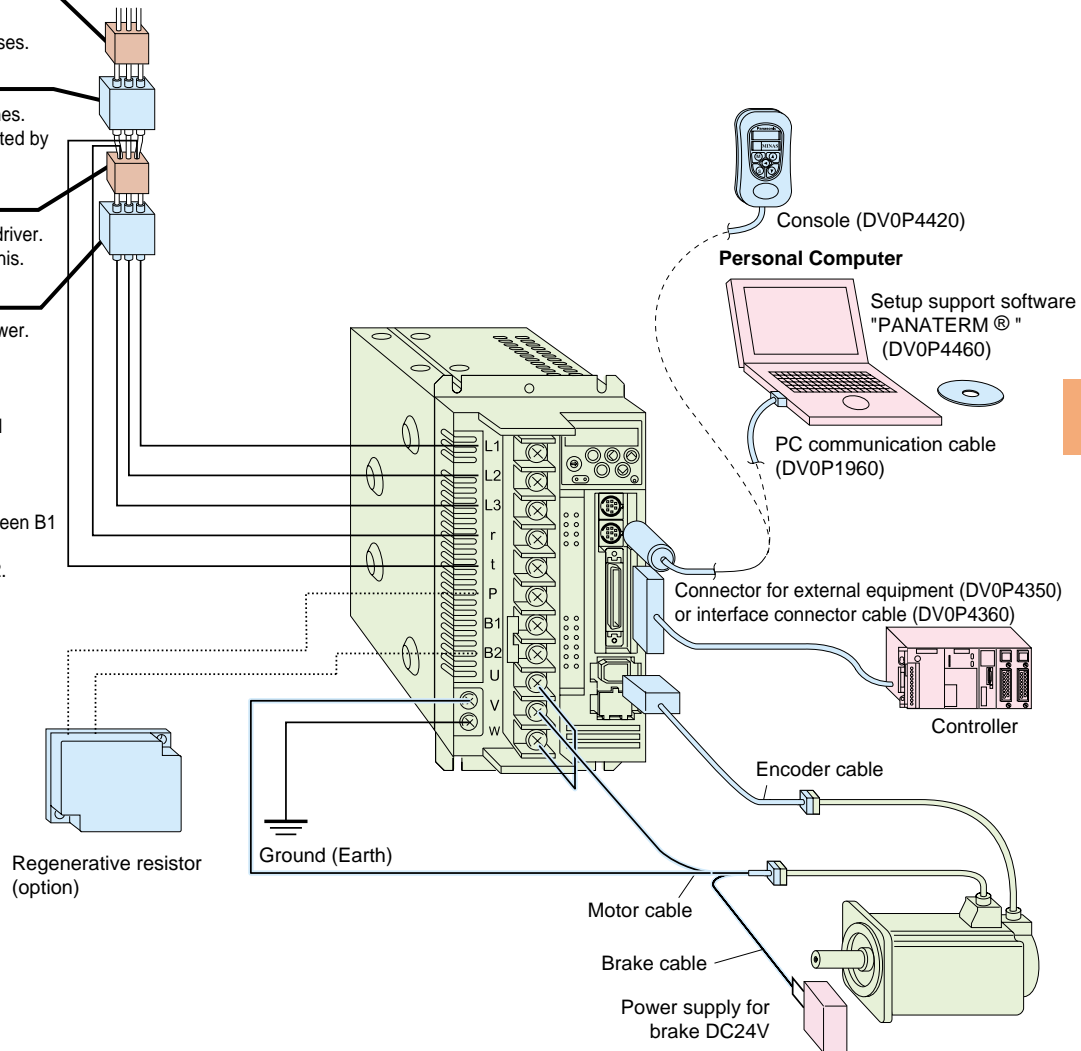

Motor to page A4-49

Driver to page A4-15

Option to page A4-113

Recommended equipments to page A4-12

Parts customer to prepare

Wiring example

Driver Frame Type Symbol (Frame G)

For details, refer to the Instruction Manual.

●Wiring of main circuit

Magnetic Circuit Breaker (MCB)

Used to protect the power lines: overcurrent will shutoff the circuit.

Noise filter (NF)

Prevents external noise coming from the power line, or reduces noise generated by the servo motor.

Magnetic contactor (MC)

Turns on/off the main power to the servo motor.
Used together with a surge absorber.

Reactor (L)

Reduces harmonics in power line.

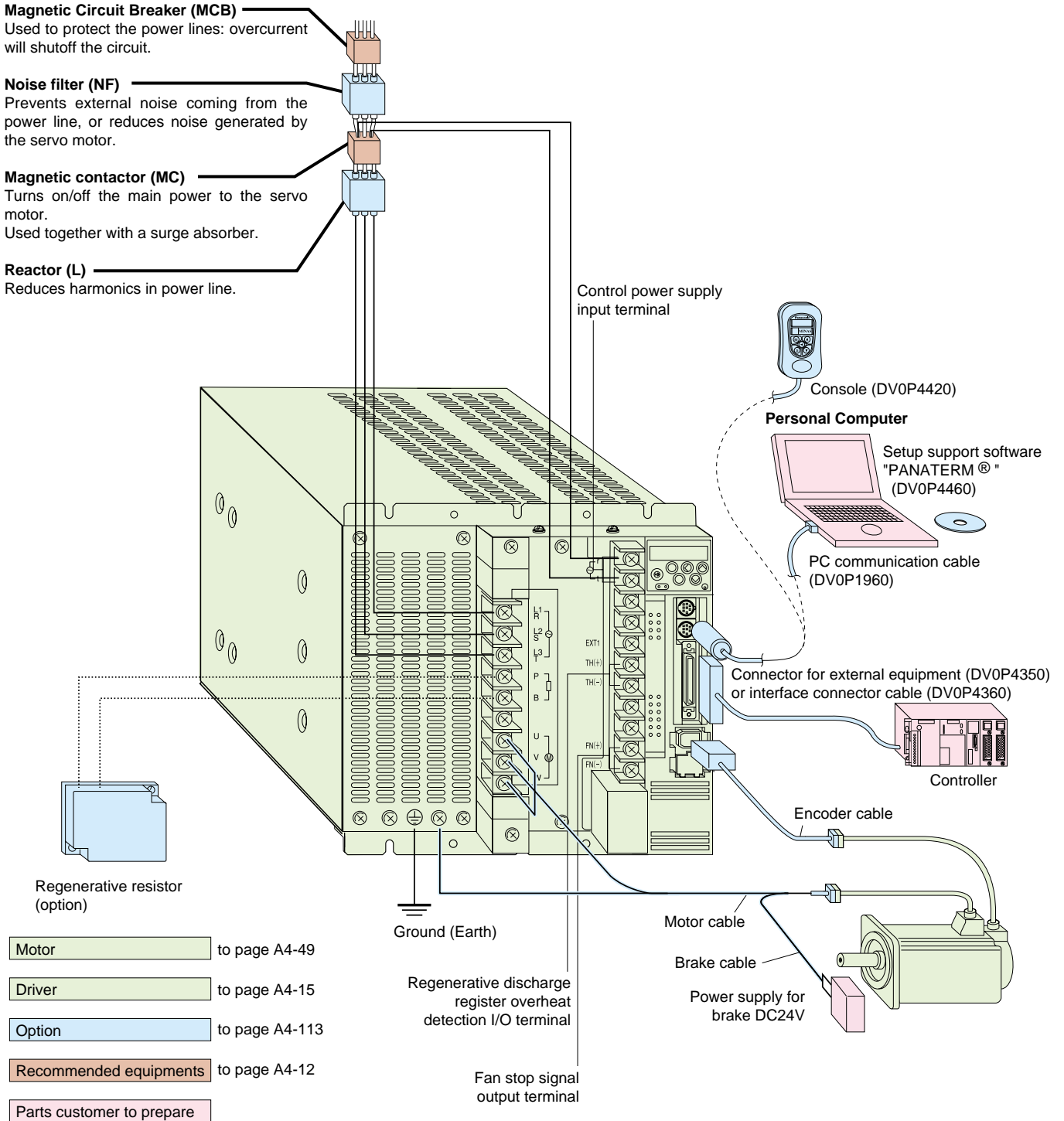

List of recommended peripheral equipments

Power supply voltage	Applicable motor		Power capacity (at rated load)	Circuit breaker (rated current)	Noise filter	Surge absorber	Noise filter (signal)	Magnetic contactor (Contact)	Cable diameter (Main circuit)	Cable diameter (control circuit)	Connector	
	Series	Output										
Single phase, 100V	MSMD	50W	Approx. 0.4kVA	BBC 2101N (10A)	DV0P 4170	DV0P 4190	DV0P 1460	BMFT61041N (3P+1a)	0.75mm ² to 2.0mm ² AWG14 to 18		Connection to exclusive connector	
	MSMD	100W										
	MQMA	200W	Approx. 0.5kVA									
		400W	Approx. 0.9kVA									
Single phase, 200V	MSMD	50W	Approx. 0.5kVA									
		100W	Approx. 0.3kVA									
	MAMA MQMA	100W	Approx. 0.3kVA									
		200W	Approx. 0.5kVA									
	MSMD MQMA	200W	Approx. 0.5kVA									
		400W	Approx. 0.9kVA									
	Single/ 3-phase, 200V	MAMA	400W	Approx. 0.9kVA	BBC 3151N (15A)	DV0P 4180	DV0P 1460	DV0P 1450	BMFT61541N (3P+1a)	2.0mm ² AWG14	0.75mm ² AWG18	Connection to exclusive connector
		MFMA	500W									
MSMD		750W	Approx. 1.1kVA									
MAMA			Approx. 1.3kVA									
MDMA		1.0kW	Approx. 1.8kVA	BBC 3201N (20A)	DV0P 4220							
MHMA		900W										
MGMA		1.0kW										
MSMA		1.0kW										
3-phase, 200V	MSMA	2.0kW	Approx. 3.3kVA	BBC 3301N (30A)	DV0P 4180	DV0P 1450	DV0P 1450	BMFT61842N (3P+1a)	3.5mm ² AWG12		Connection to terminal block M5	
	MDMA											
	MHMA											
	MFMA	2.5kW	Approx. 3.8kVA	BBC 3501N (50A)	DV0P 3410							
	MGMA	2.0kW										
	MSMA	3.0kW	Approx. 4.5kVA									
								MDMA				
								MHMA				
	MSMA	4.0kW	Approx. 6.0kVA									
				MDMA								
	MFMA	4.5kW	Approx. 6.8kVA	BBC 3601N (60A)	DV0P 3410							
	MGMA											
MSMA	5.0kW	Approx. 7.5kVA										
			MDMA									
			MHMA									
MGMA	6.0kW	Approx. 9.0kVA	BBC 3601N (60A)	DV0P 3410								
MDMA	7.5kW				Approx. 11kVA							
MHMA								L1, L2, L3 5.3mm ² AWG10 U, V, W 14mm ² AWG6				

- Select a single and 3-phase common specifications corresponding to the power supplies.
- Listed circuit breaker and magnetic contactor are manufactured by Matsushita Electric Works.
To conform to EC Directives, install a circuit breaker which conforms to IEC and UL Standards (UL Listed and  marked) between noise filter and power supply without fail.
- For details of noise filter, refer to Page A4-110.

<Remarks>

- Select a circuit breaker and noise filter which match to the capacity of power supply (including a load condition).
- Terminal block and earth terminals
Use a copper conductor cables with temperature rating of 60°C or higher.
Earth terminals for Frame A to D are M4 and M5 for Frame E to F.
Larger tightening torque for screws than the max. value (M4 : 1.2 N · m, M5 : 2.0 N · m) may damage the terminal block.
- Use an earth cable with diameter of 2.0mm² (AWG14) or larger for 50W to 2.5kW, 3.5mm² (AWG12) or larger for 3kW to 4kW, 5.3mm² (AWG10) or larger for 4.5kW to 5kW and 14mm² (AWG6) or larger for 6kW to 7.5kW.
- Use the attached exclusive connector for A to D-frame, and maintain the peeled off length of 8-9mm.
- Tighten the screws of the connector, CN X5 for the host controller with the torque of 0.3 to 0.35 N · m.

Table of Part Numbers and Options

Power supply	Motor series	Rated rotational speed (r/min)	Output (W)	2500P/r, Incremental			17bit, Absolute/Incremental common				2500P/r and 17bit common		
				Motor Note) 1	Rating/Spec. (page)	Encoder cable Note) 2	Motor Note) 1	Rating/Spec. (page)	Encoder cable Note) 2	Encoder cable Note) 2	Driver	Frame symbol	
Single phase 200V	MAMA Ultra	5000	100	MAMA012P1	A4-49		MAMA012S1	A4-49			MADDT1207	A-frame	
			200	MAMA022P1	A4-49		MAMA022S1	A4-49			MBDDT2210	B-frame	
			400	MAMA042P1	A4-49		MAMA042S1	A4-49			MCDDT3520	C-frame	
			750	MAMA082P1	A4-49		MAMA082S1	A4-49			MDDDT5540	D-frame	
	3-phase, 200V	low inertia		400	MAMA042P1	A4-49		MAMA042S1	A4-49			MCDDT3520	C-frame
				750	MAMA082P1	A4-49		MAMA082S1	A4-49			MDDDT5540	D-frame
Single phase 100V	MSMD Low inertia		50	MSMD5AZP1	A4-51		MSMD5AZS1	A4-51			MADDT1105	A-frame	
			100	MSMD011P1	A4-51		MSMD011S1	A4-51			MADDT1107		
			200	MSMD021P1	A4-53		MSMD021S1	A4-53			MBDDT2110	B-frame	
			400	MSMD041P1	A4-53		MSMD041S1	A4-53			MCDDT3120	C-frame	
	MQMA Low inertia Flat			100	MQMA011P1	A4-59	MFECA 0* * 0EAM	MQMA011S1	A4-59	MFECA 0* * 0EAE	MFECA 0* * 0EAD	MADDT1107	A-frame
				200	MQMA021P1	A4-59		MQMA021S1	A4-59			MBDDT2110	B-frame
				400	MQMA041P1	A4-59		MQMA041S1	A4-59			MCDDT3120	C-frame
Single phase 200V	MSMD Low inertia	3000	50	MSMD5AZP1	A4-55		MSMD5AZS1	A4-55			MADDT1205	A-frame	
			100	MSMD012P1	A4-55		MSMD012S1	A4-55			MADDT1207		
			200	MSMD022P1	A4-57		MSMD022S1	A4-57			MBDDT2210	B-frame	
			400	MSMD042P1	A4-57		MSMD042S1	A4-57			MCDDT3520	C-frame	
			750	MSMD082P1	A4-57		MSMD082S1	A4-57					
	MQMA Low inertia Flat			100	MQMA012P1	A4-61		MQMA012S1	A4-61			MADDT1205	A-frame
				200	MQMA022P1	A4-61		MQMA022S1	A4-61			MADDT1207	
				400	MQMA042P1	A4-61		MQMA042S1	A4-61			MBDDT2210	B-frame
	MSMA Low inertia			1000	MSMA102P1	A4-63		MSMA102S1	A4-63			MDDDT5540	
				1500	MSMA152P1	A4-63		MSMA152S1	A4-63				
	MDMA Middle inertia	2000		1000	MDMA102P1	A4-67		MDMA102S1	A4-67			MDDDT3530	D-frame
				1500	MDMA152P1	A4-67		MDMA152S1	A4-67				
	MGMA Middle inertia	1000		900	MGMA092P1	A4-73	MFECA 0* * 0ESD	MGMA092S1	A4-73	MFECA 0* * 0ESE	MFECA 0* * 0ESD	MDDDT5540	
	MFMA Middle inertia	2000		400	MFMA042P1	A4-77		MFMA042S1	A4-77			MCDDT3520	C-frame
				1500	MFMA152P1	A4-77		MFMA152S1	A4-77			MDDDT5540	D-frame
				500	MHMA052P1	A4-81		MHMA052S1	A4-81			MCDDT3520	C-frame
				1000	MHMA102P1	A4-81		MHMA102S1	A4-81			MDDDT3530	D-frame
1500				MHMA152P1	A4-81		MHMA152S1	A4-81			MDDDT5540		
3-phase, 200V	MSMD Low inertia		750	MSMD082P1	A4-57	MFECA 0* * 0EAM	MSMD082S1	A4-57	MFECA 0* * 0EAE	MFECA 0* * 0EAD	MCDDT3520	C-frame	
	MSMA Low inertia	3000		1000	MSMA102P1	A4-63		MSMA102S1	A4-63			MDDDT5540	D-frame
				1500	MSMA152P1	A4-63		MSMA152S1	A4-63				
				2000	MSMA202P1	A4-63		MSMA202S1	A4-63			MEDDT7364	E-frame
				3000	MSMA302P1	A4-65		MSMA302S1	A4-65			MFDDTA390	
				4000	MSMA402P1	A4-65		MSMA402S1	A4-65			MFDDTB3A2	F-frame
	MDMA Middle inertia	2000 (Note) 3		5000	MSMA502P1	A4-65		MSMA502S1	A4-65			MFDDTB3A2	
				1000	MDMA102P1	A4-67		MDMA102S1	A4-67			MDDDT3530	D-frame
				1500	MDMA152P1	A4-67		MDMA152S1	A4-67			MDDDT5540	
				2000	MDMA202P1	A4-69		MDMA202S1	A4-69			MEDDT7364	E-frame
				3000	MDMA302P1	A4-69		MDMA302S1	A4-69			MFDDTA390	
				4000	MDMA402P1	A4-71		MDMA402S1	A4-71			MFDDTB3A2	F-frame
	MGMA Middle inertia	1000		5000	MDMA502P1	A4-71		MDMA502S1	A4-71			MGDDTC3B4	G-frame
				7500	MDMA752P1	A4-71		MDMA752S1	A4-71				
				900	MGMA092P1	A4-73		MGMA092S1	A4-73			MDDDT5540	D-frame
				2000	MGMA202P1	A4-73	MFECA 0* * 0ESD	MGMA202S1	A4-73	MFECA 0* * 0ESE	MFECA 0* * 0ESD	MFDDTA390	
				3000	MGMA302P1	A4-75		MGMA302S1	A4-75			MFDDTB3A2	F-frame
	MFMA Middle inertia			4500	MGMA452P1	A4-75		MGMA452S1	A4-75			MGDDTC3B4	G-frame
				6000	MGMA602P1	A4-75		MGMA602S1	A4-75				
				400	MFMA042P1	A4-77		MFMA042S1	A4-77			MCDDT3520	C-frame
				1500	MFMA152P1	A4-77		MFMA152S1	A4-77			MDDDT5540	D-frame
	MHMA High inertia	2000 (Note) 3		2500	MFMA252P1	A4-79		MFMA252S1	A4-79			MEDDT7364	E-frame
				4500	MFMA452P1	A4-79		MFMA452S1	A4-79			MFDDTB3A2	F-frame
500				MHMA052P1	A4-81		MHMA052S1	A4-81			MCDDT3520	C-frame	
1000				MHMA102P1	A4-81		MHMA102S1	A4-81			MDDDT3530	D-frame	
1500				MHMA152P1	A4-81		MHMA152S1	A4-81			MDDDT5540		
2000				MHMA202P1	A4-83		MHMA202S1	A4-83			MEDDT7364	E-frame	
3000				MHMA302P1	A4-83		MHMA302S1	A4-83			MFDDTA390		
4000				MHMA402P1	A4-83		MHMA402S1	A4-83			MFDDTB3A2	F-frame	
MHMA High inertia			5000	MHMA502P1	A4-83		MHMA502S1	A4-83			MFDDTB3A2		
			7500	MHMA752P1	A4-85		MHMA752S1	A4-85			MGDDTC3B4	G-frame	

Optional parts						
Motor cable Note) 2	Motor cable (with brake) Note) 2	Brake cable Note) 2	Regenerative resistor	Reactor	Noise filter	
			DV0P4283	DV0P220	DV0P4170	
			DV0P4284	DV0P221	DV0P4180 DV0P4220	
			DV0P4283	DV0P220	DV0P4180	
			DV0P4284	DV0P221	DV0P4220	
			DV0P4280	DV0P227	DV0P4170	
			DV0P4283	DV0P228	DV0P4180	
			DV0P4282			
MFMCA 0* *0EED	—	MFMCB 0* *0GET	DV0P4280	DV0P227	DV0P4170	
			DV0P4283	DV0P228	DV0P4180	
			DV0P4282			
			DV0P4281	DV0P220	DV0P4170	
			DV0P4283	DV0P221	DV0P4180	
			DV0P4281	DV0P220	DV0P4170	
			DV0P4283	DV0P221	DV0P4180	
			DV0P4284	DV0P222	DV0P4220	
MFMCD 0* *2ECD	MFMCA 0* *2FCD	—	DV0P4283	DV0P220	DV0P4180	
			DV0P4284	DV0P222	DV0P4220	
MFMCA 0* *2ECD			DV0P4283	DV0P220	DV0P4180	
MFMCD 0* *2ECD			DV0P4284	DV0P222	DV0P4220	
MFMCA 0* *0EED	—	MFMCB 0* *0GET	DV0P4283	DV0P221	DV0P4180	
MFMCD 0* *2ECD	MFMCA 0* *2FCD		DV0P4284	DV0P222	DV0P4220	
MFMCD0* *2ECT	MFMCA0* *2FCT		DV0P4285	DV0P223		
MFMCA 0* *3ECT	MFMCA 0* *3FCT		DV0P4285	DV0P224 DV0P225	DV0P3410	
MFMCD 0* *2ECD	MFMCA 0* *2FCD		DV0P4284	DV0P222	DV0P4220	
MFMCD0* *2ECT	MFMCA0* *2FCT		DV0P4285	DV0P223		
MFMCA 0* *3ECT	MFMCA 0* *3FCT		DV0P4285	DV0P224 DV0P225	DV0P3410	
—	—		DV0P4285 X4 in parallel	—	DV0P3410	
MFMCD 0* *2ECD	MFMCA 0* *2FCD	—	DV0P4284	DV0P222	DV0P4220	
MFMCA 0* *3ECT	MFMCA 0* *3FCT		DV0P4285	DV0P223 DV0P224	DV0P3410	
—	—		DV0P4285 X4 in parallel	—		
MFMCA 0* *2ECD	MFMCA 0* *2FCD		DV0P4283	DV0P220	DV0P4180	
MFMCD 0* *3ECT	MFMCA 0* *3FCT		DV0P4284	DV0P222	DV0P4220	
—	—		DV0P4285	DV0P224	DV0P3410	
MFMCA 0* *3ECT	MFMCA 0* *3FCT		DV0P4285 X2 in parallel	—	DV0P3410	
MFMCD 0* *2ECD	MFMCA 0* *2FCD		DV0P4283	DV0P220	DV0P4180	
—	—		DV0P4284	DV0P222	DV0P4220	
MFMCA 0* *3ECT	MFMCA 0* *3FCT		DV0P4285	DV0P223		
—	—		DV0P4285 X4 in parallel	—		
MFMCA 0* *3ECT	MFMCA 0* *3FCT		DV0P4285	DV0P224 DV0P225	DV0P3410	
—	—		DV0P4285 X4 in parallel	—		

Carrying page

Options		Part No.	Carrying page
Instruction manual	Japanese	DV0P4200	—
	English	DV0P4210	—
Console		DV0P4420	A4-124
Setup support software, PANATERM [®]	Japanese	DV0P4460	A4-123
	English		
RS232 communication cable (for connection with PC)		DV0P1960	A4-119
RS485 communication cable		DV0P1970 DV0P1971 DV0P1972	A4-119
Interface cable		DV0P4360	A4-119
Connector kit for external equipment		DV0P4350	A4-118
Connector kit for motor and encoder		DV0P4290	A4-120
		DV0P4380	
		DV0P4310	
		DV0P4320	A4-121
		DV0P4330	
		DV0P4340	A4-122
		DV0P3470	
	DV0P3480		
Battery for absolute encoder		DV0P2990	A4-126
Mounting bracket	Frame A	DV0P4271	A4-123
	Frame B	DV0P4272	
	Frame C	DV0P4273	
	Frame D	DV0P4274	
Encoder cable	MFECA0* *0EAD	A4-115	
	MFECA0* *0EAE		
	MFECA0* *0EAM		
	MFECA0* *0ESD		
	MFECA0* *0ESE		
Motor cable	MFMCA0* *0EED	A4-116	
	MFMCA0* *2ECD		
	MFMCA0* *3ECT		
	MFMCD0* *2ECD		
	MFMCD0* *2ECT		
	MFMCD0* *3ECT		
Motor cable (with brake)	MFMCA0* *2FCD	A4-117	
	MFMCA0* *2FCT		
	MFMCA0* *3FCT		
Brake cable		MFMCB0* *0GET	A4-117
Regenerative resistor	50Ω, 25W	DV0P4280	A4-125
	100Ω, 25W	DV0P4281	
	25Ω, 50W	DV0P4282	
	50Ω, 50W	DV0P4283	
	30Ω, 100W	DV0P4284	
	20Ω, 130W	DV0P4285	
Reactor		DV0P220 to DV0P228	A4-124
Noise filter		DV0P4170 DV0P4180 DV0P4220 DV0P3410	A4-110
Surge absorber	Single phase 100V, 200V	DV0P4190	A4-110
	3-phase 200V	DV0P1450	
Noise filter for signal wire		DV0P1460	A4-111

Note) 1. □ represents the motor structure.

Note) 2. **represents the cable length (specified value)
For details, refer to cable specifications (A4-113).

Note) 3. 7.5kW output type: 1500(r/min)

Common Specifications of Driver

Basic Specifications	Input power	100V	Main circuit	Single phase, 100-115V	+10% -15%	50/60Hz	
			Control circuit	Single phase, 100-115V	+10% -15%	50/60Hz	
		200V	Main circuit	Frame A, B	Single phase, 200-240V	+10% -15%	50/60Hz
				Frame C, D	Single/3-phase, 200-240V	+10% -15%	50/60Hz
			Control circuit	Frame E to G	3-phase, 200-230V	+10% -15%	50/60Hz
				Frame A to D	Single phase, 200-240V	+10% -15%	50/60Hz
	Environment		Temperature	Operating : 0 to 55°C, Storage : -20 to +80°C			
			Humidity	Both operating and storage : 90%RH or less (free from condensation)			
			Altitude	1000m or lower			
			Vibration	5.88m/s ² or less, 10 to 60Hz (No continuous use at resonance frequency)			
	Control method		IGBT PWM Sinusoidal wave drive				
	Encoder feedback		17-bit (131072 resolution) absolute/incremental encoder, 2500P/r (10000 resolution) incremental encoder				
	External scale feedback		AT500 series, ST771 by Mitutoyo				
	Control signal		Input	10 inputs (1) Servo-ON, (2) Control mode switching, (3) Gain switching/Torque limit switching, (4) Alarm clear Other inputs vary depending on the control mode.			
			Output	6 outputs (1) Servo alarm, (2) Servo ready, (3) Release signal of external brake (4) Zero speed detection, (5) Torque in-limit. Other outputs vary depending on the control mode.			
	Analog signal		Input	3 inputs (16Bit A/D : 1 input, 10Bit A/D : 2 inputs)			
			Output	2 outputs (for monitoring) (1) Speed monitor (Monitoring of actual motor speed or command speed is enabled. Select the content and scale with parameter.), (2) Torque monitor (Monitoring of torque command, (approx.. 3V/rated torque)), deviation counter or full-closed deviation is enabled. Select the content or scale with parameter.)			
	Pulse signal		Input	2 inputs Select the exclusive input for line driver or photo-coupler input with parameter.			
			Output	4 outputs Feed out the encoder pulse (A, B and Z-phase) or external scale pulse (EXA, EXB and EXZ-phase) in line driver. Z-phase and EXZ-phase pulse is also fed out in open collector.			
	Communication function		RS232	1 : 1 communication to a host with RS232 interface is enabled.			
RS485			1 : n communication up to 15 axes to a host with RS485 interface is enabled.				
		(1) 5 keys (MODE, SET, UP, DOWN, SHIFT), (2) LED (6-digit)					
Front panel Regeneration		Frame A, B : no built-in regenerative resistor (external resistor only) Frame C to F : Built-in regenerative resistor (external resistor is also enabled.)					
Dynamic brake		Setup of action sequence at Power-OFF, Servo-OFF, at protective function activation and over-travel inhibit input is enabled.					
Control mode		Switching among the following 7 mode is enabled, (1) Position control, (2) Velocity control, (3) Toque control, (4) Position/Velocity control, (5) Position/Torque control, (6) Velocity/Torque control and (7) Full-closed control.					

Functions	Position control	Control input		① Deviation counter clear, ② Command pulse inhibition, ③ Electronic gear switching, ④ Damping control switching	
		Control output		① Positioning complete (In-position)	
		Pulse input	Max. command pulse frequency	Exclusive interface for line driver : 2Mpps, Line driver : 500kpps, Open collector : 200kpps	
			Input pulse signal format	Support (1) RS422 line drive signal and (2) Open collector signal from controller.	
			Type of input pulse	Differential input. Selectable with parameter, ((1) CW/CCW, (2) A and B-phase, (3) Command and Direction)	
			Electronic gear (Division/Multiplication of command pulse)	Process the command pulse frequency $\times \frac{(1 \text{ to } 10000) \times 2^{(0-17)}}{1 \text{ to } 10000}$ as a position command input	
			Smoothing filter	Primary delay filter or FIR type filter is selectable to the command input.	
		Analog input	Torque limit command input	Individual torque limit for both CW and CCW direction is enabled. (3V/rated torque)	
		Instantaneous speed observer		Usable	
		Damping control		Usable	
	Velocity control	Control input		① Speed zero clamp, ② Selection of internal speed setup, ③ Gain switching or Torque limit switching input	
		Control output		① Speed arrival (at-speed)	
		Analog input	Velocity command input	Setup of scale and rotational direction of the motor against the command voltage is enabled with parameter, with the permissible max. voltage input = $\pm 10V$ and 6V/rated speed (default setup).	
			Torque limit command input	Individual torque limit for both CW and CCW direction is enabled. (3V/rated torque)	
		Speed control range		1 : 5000	
		Internal speed command		8-speed with parameter setup	
		Soft-start/down function		Individual setup of acceleration and deceleration is enabled, with 0 to 10s/1000r/min. S-shaped acceleration/deceleration is also enabled.	
		Zero-speed clamp		0-clamp of internal speed command with speed zero clamp input is enabled.	
		Instantaneous speed observer		Usable	
		Speed command filter		Usable	
	Torque control	Control input		① Speed zero clamp	
		Control output		① Speed arrival (at-speed)	
		Analog input	Speed command input	Setup of scale and CW/CCW torque generating direction of the motor against the command voltage is enabled with parameter, with the permissible max. voltage input = $\pm 10V$ and 3V/rated speed (default setup).	
			Speed limit input	Speed limit input by analog voltage is enabled. Scale setup with parameter.	
		Speed limit function		Speed limit value with parameter or analog input is enabled.	
	Full-closed control	Control input		① Deviation counter clear, ② Command pulse input inhibition, ③ Electronic gear switching, ④ Damping control switching	
		Control output		① Full-closed positioning complete (in-position)	
		Pulse input	Max. command pulse frequency	Exclusive interface for line driver : 2Mpps, Line driver : 500kpps, Open collector : 200kpps	
			Input pulse signal format	Differential input. Selectable with parameter ((1) CCW/CW, (2) A and B-phase, (3) Command and direction)	
			Electronic gear (Division/Multiplication of command pulse)	Process the command pulse frequency $\times \frac{(1 \text{ to } 10000) \times 2^{(0-17)}}{1 \text{ to } 10000}$ as a position command input	
			Smoothing filter	Primary delay filter is adaptable to the command input.	
		Analog input	Torque limit command input	Individual torque limit for both CW and CCW direction is enabled. (3V/rated torque)	
		Setup range of division / multiplication of external scale		Setting of ratio between encoder pulse (denominator) and external scale pulse (numerator) is enabled within a range of $(1 \text{ to } 10000) \times 2^{(0-17)} / (1 \text{ to } 10000)$.	
		Common	Auto-gain tuning	Real-time	Corresponds to load inertia fluctuation, possible to automatically set up parameters related to notch filter.
				Normal mode	Estimates load inertia and sets up an appropriate servo gain.
	Fit-gain function			Automatically searches and sets up the value which makes the fastest settling time with external command input.	
	Masking of unnecessary input		Masking of the following input signal is enabled. (1) Over-travel inhibition, (2) Torque limit, (3) Command pulse inhibition, (4) Speed-zero clamp, (5) Counter clear		
	Division of encoder feedback pulse		Set up of any value is enabled (encoder pulses count is the max.).		
	Protective function		Soft error	Over-voltage, under-voltage, over-speed, over-load, over-heat, over-current and encoder error etc.	
			Hard error	Excess position deviation, command pulse division error, and EEPROM error etc.	
	Traceability of alarm data		Traceable up to past 14 alarms including the present one.		
	Damping control function		Manual setup with parameter		
Setup	Manual		5push switches on front panel <input type="button" value="MODE"/> <input type="button" value="SET"/> <input type="button" value="▲"/> <input type="button" value="▼"/> <input type="button" value="◀"/>		
	Setup support software	PANATERM® (Supporting OS : Windows98, Windows ME, Windows2000, and WindowsXP)			

Standard Wiring Example of Main Circuit

■ Frame A, B

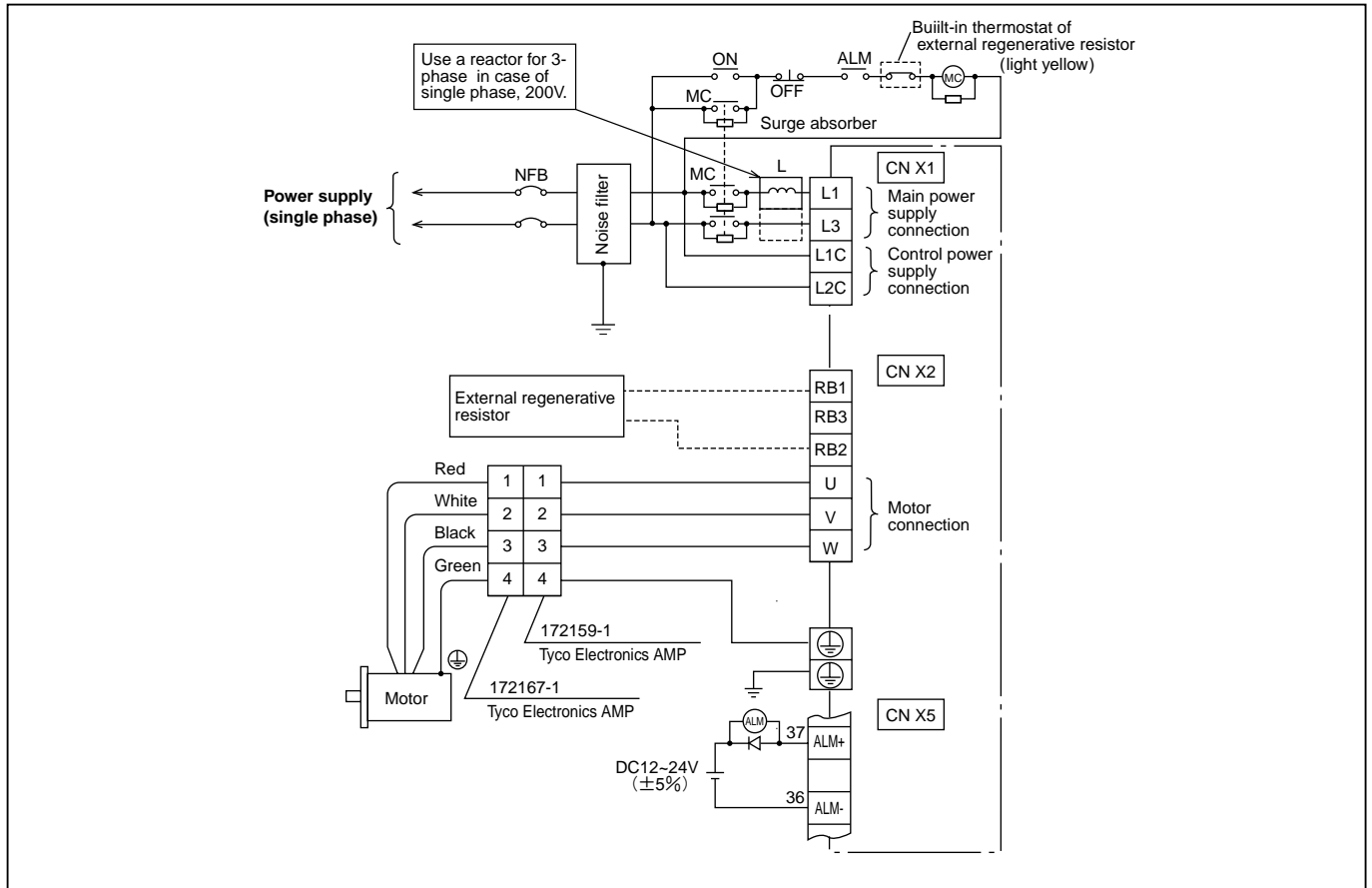

■ Frame C, D

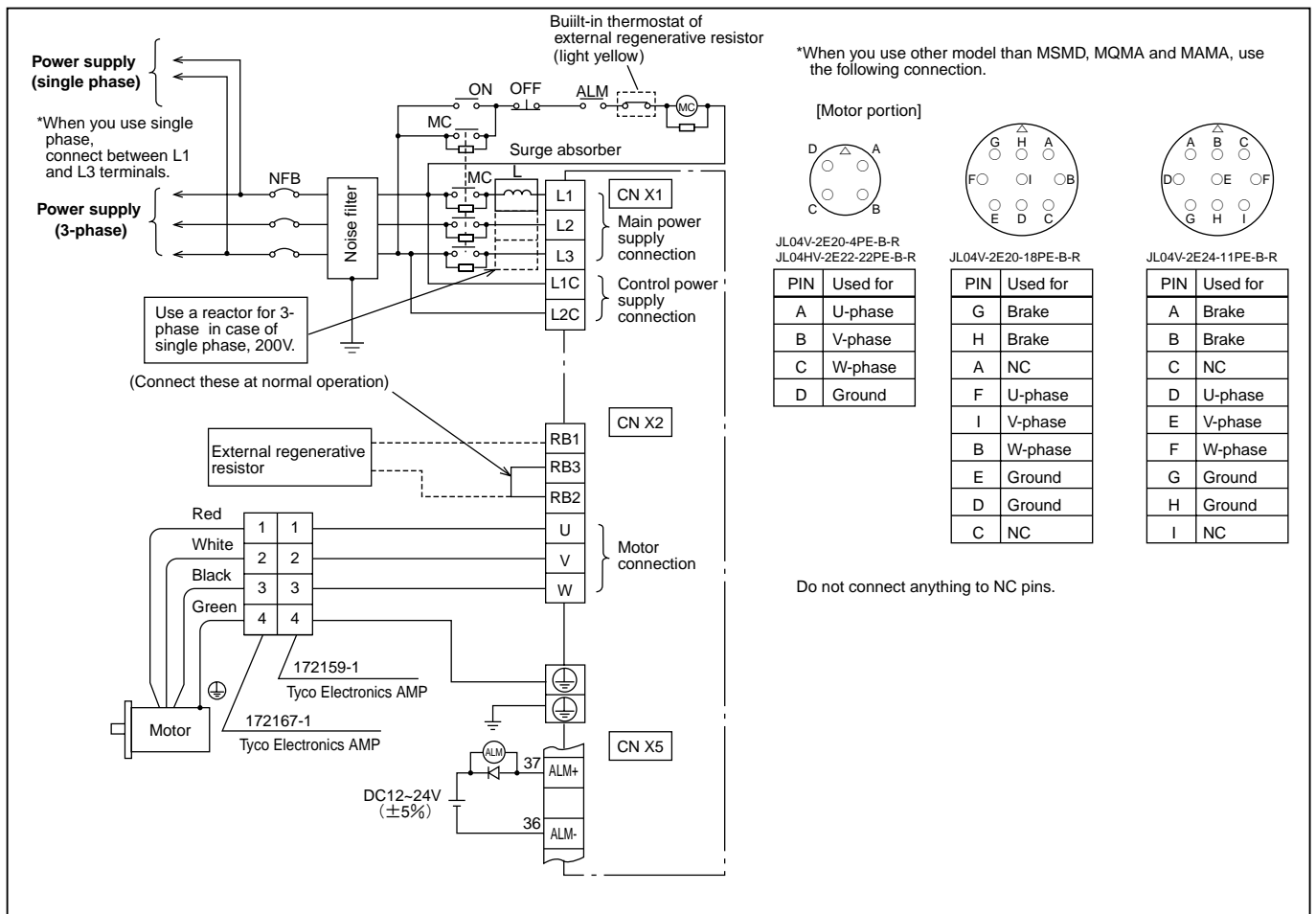

Frame E, F

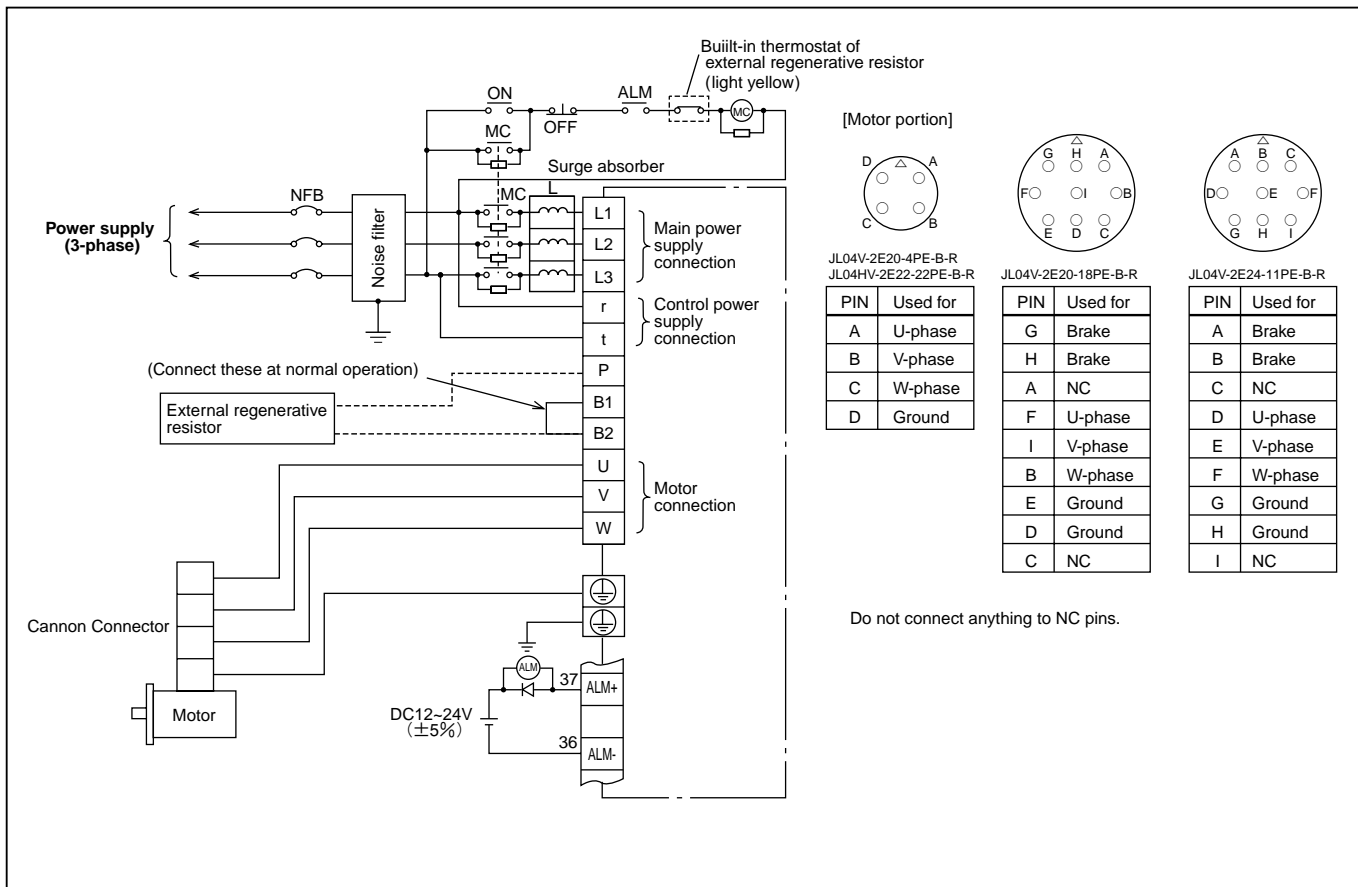

Frame G

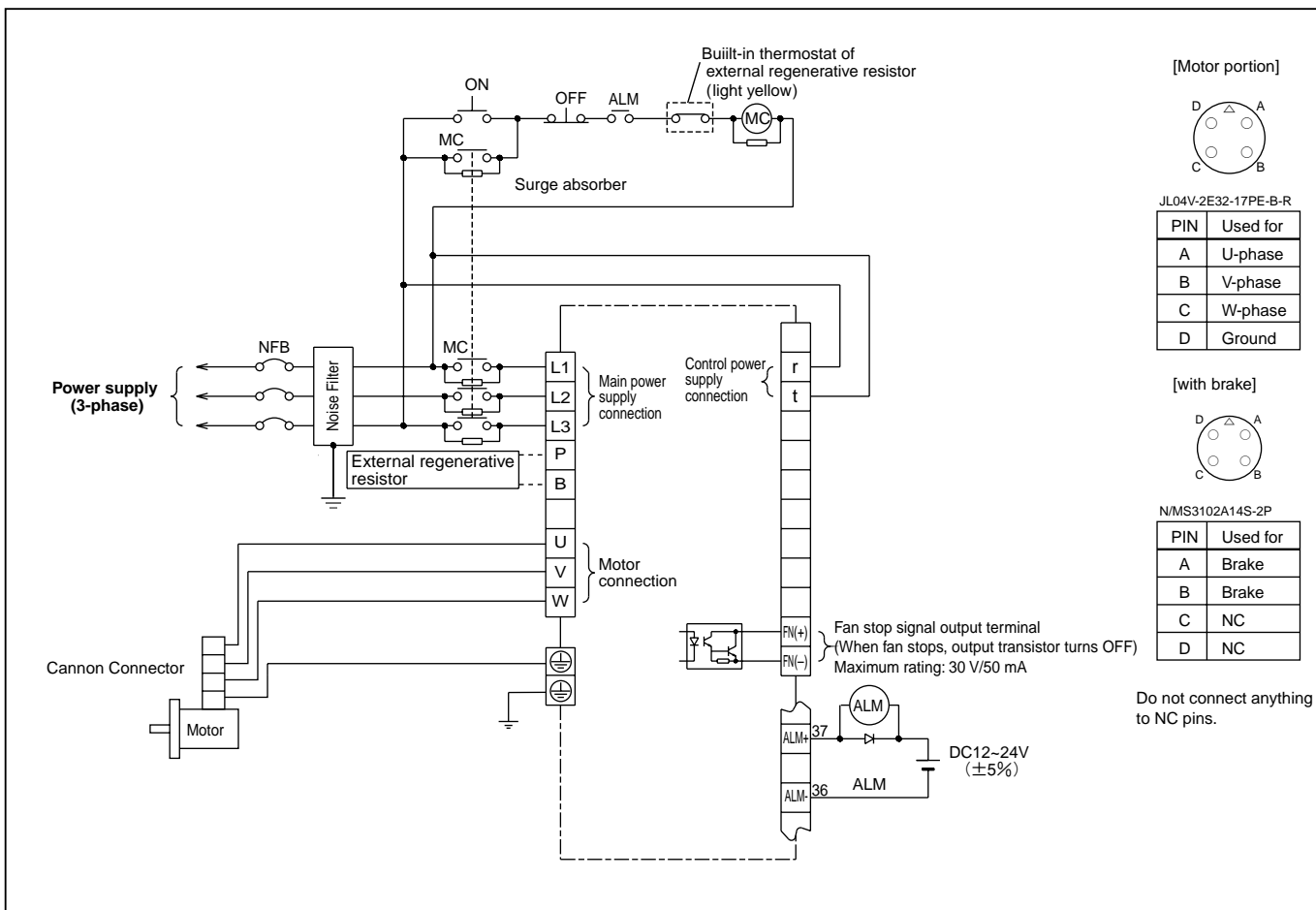

MINAS A4 Standard Wiring Example of Main Circuit

Encoder Wiring Diagram

2500P/r Incremental encoder

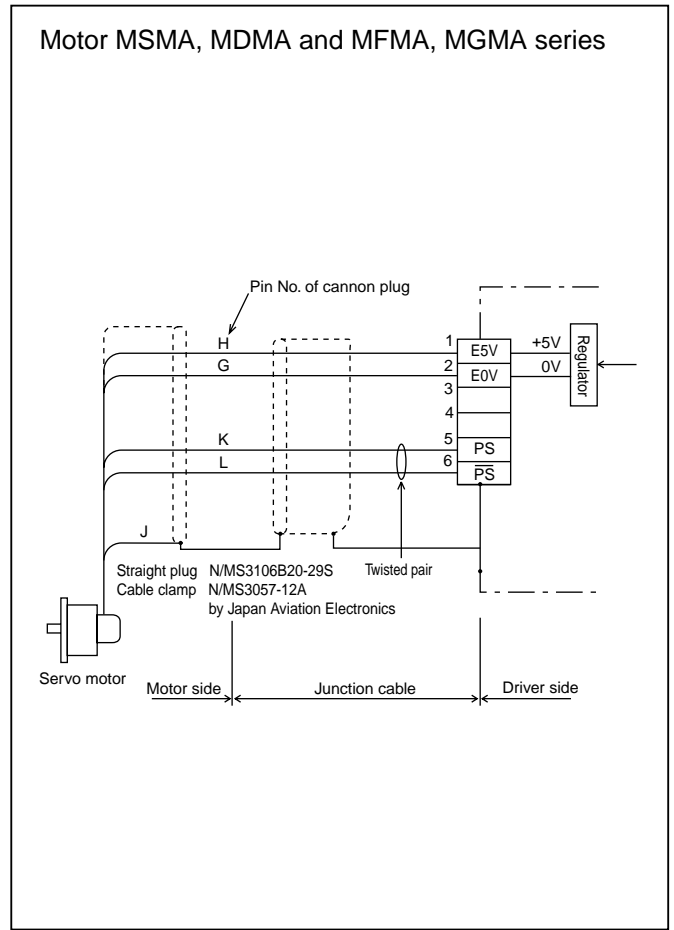
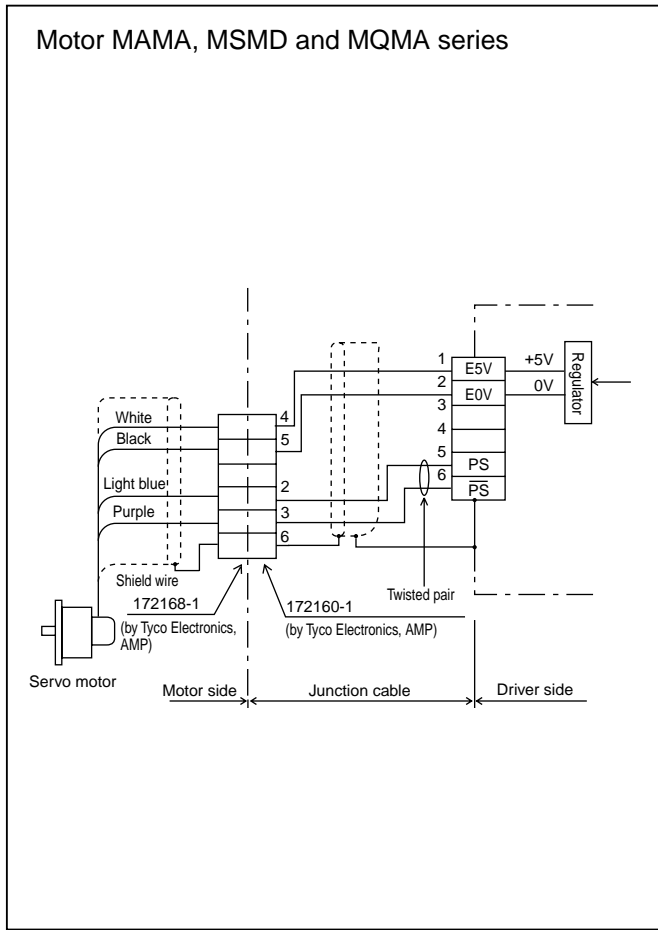

17bit Absolute encoder

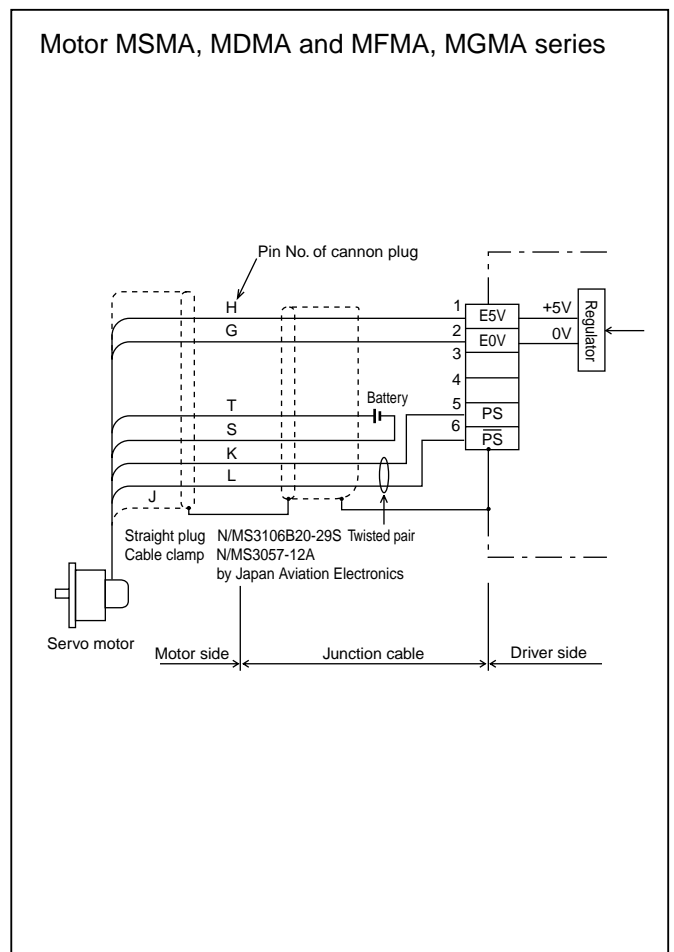
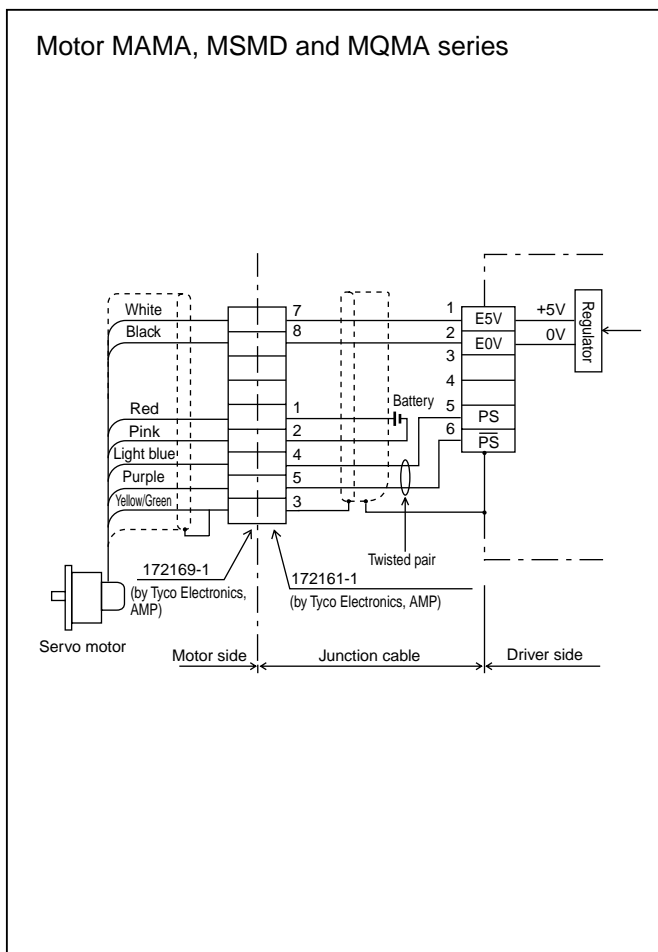

Standard Wiring Example of Control Circuit

Wiring examples at each control mode

● CN X5 Wiring example at position control mode

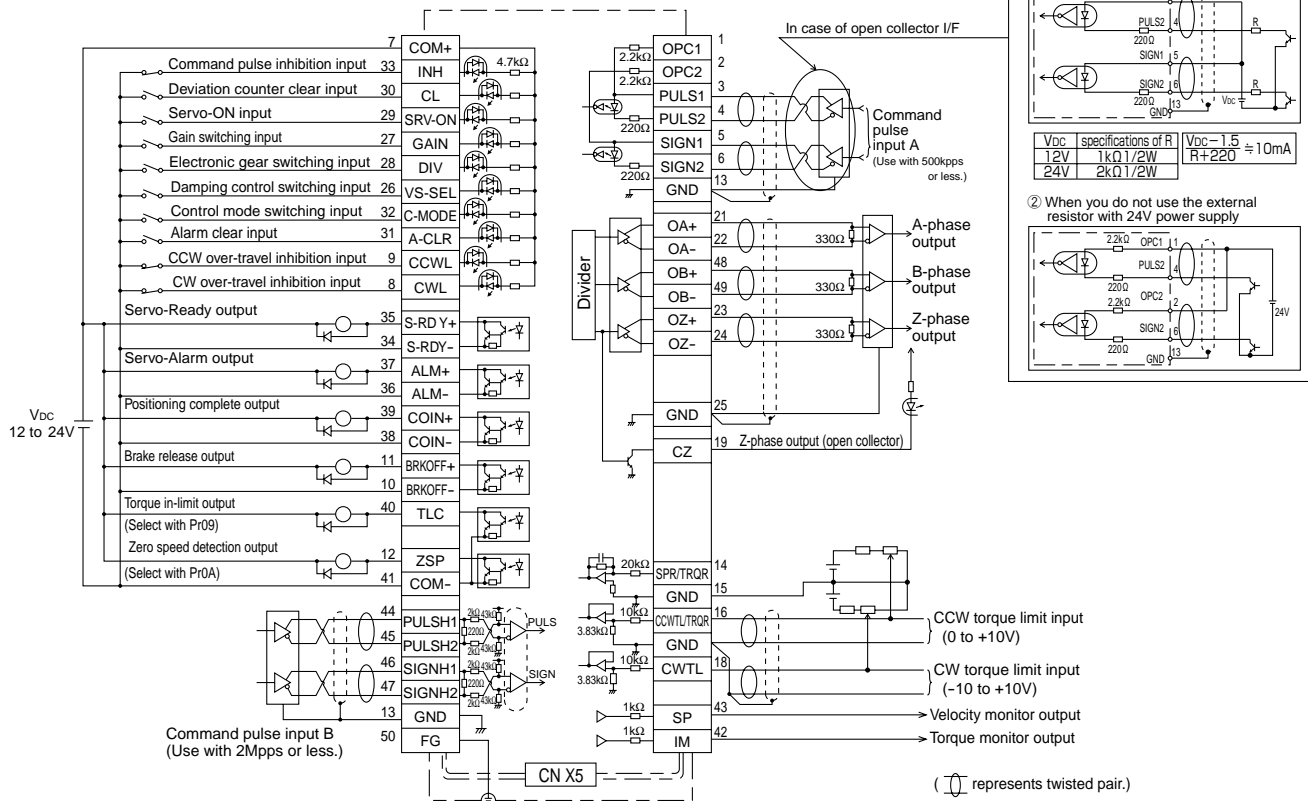

MINAS A4 Encoder Wiring Diagram / Standard Wiring Example of Control Circuit

● CN X5 Wiring example at velocity control mode

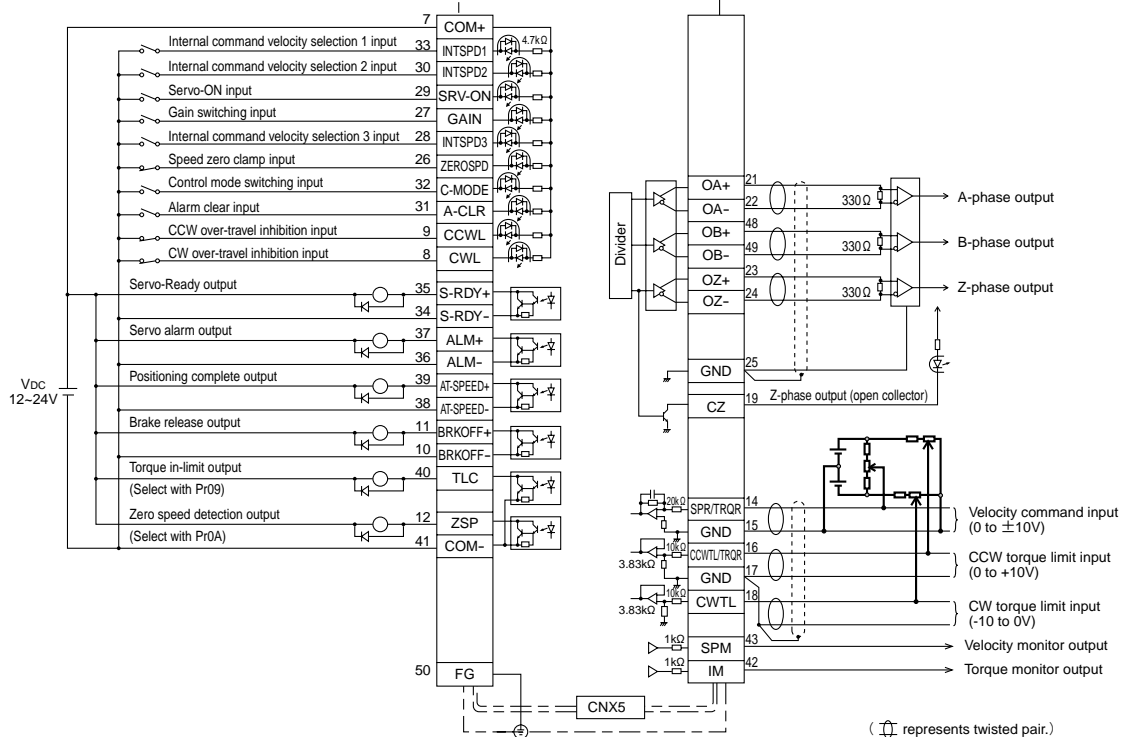

● CN X5 Wiring example at torque control mode

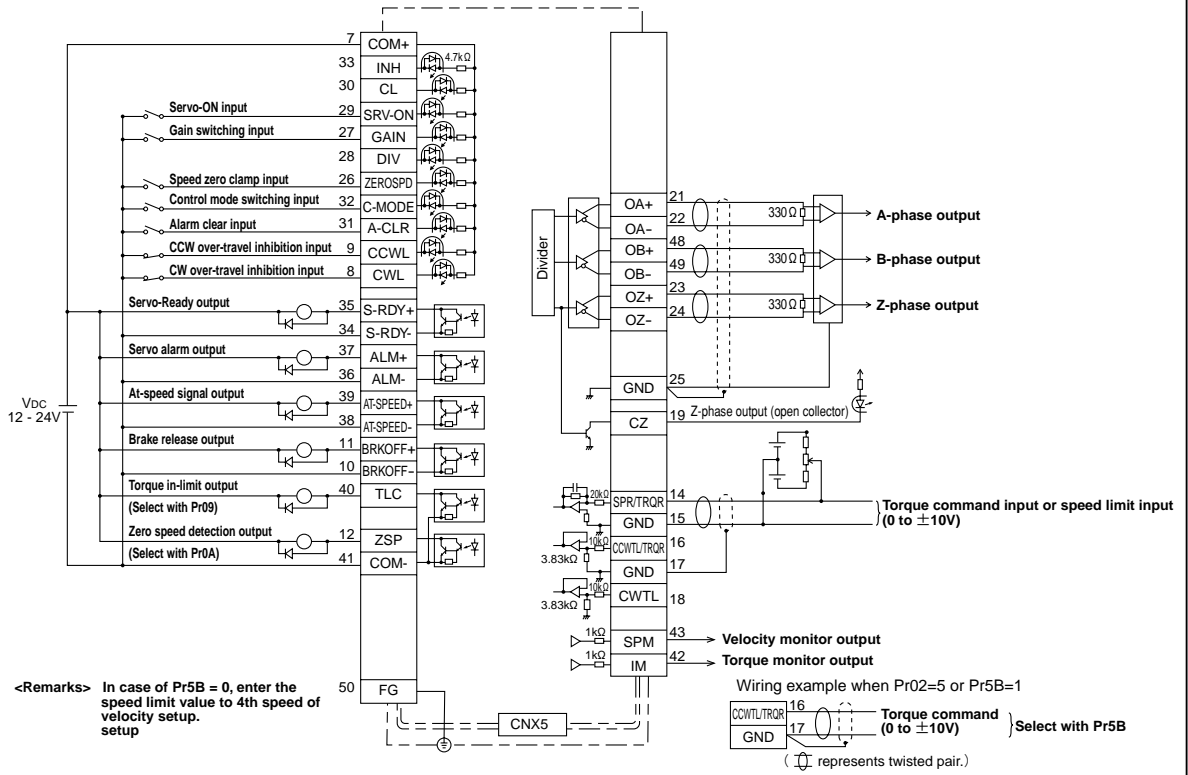

Table of Applicable Motors

Driver		Motor series							
Frame symbol	Part No.	MAMA	MSMD	MQMA	MSMA	MDMA	MGMA	MFMA	MHMA
A-frame	MADDT1105		MSMD5AZ***						
	MADDT1107		MSMD011***	MQMA011***					
	MADDT1205		MSMD5AZ***	MQMA012***					
			MSMD012***						
B-frame	MADDT1207	MAMA012***	MSMD022***	MQMA022***					
	MBDDT2110		MSMD021***	MQMA021***					
C-frame	MBDDT2210	MAMA022***	MSMD042***	MQMA042***					
	MCDDT3120		MSMD041***	MQMA041***					
D-frame	MCDDT3520	MAMA042***	MSMD082***					MFMA042***	MHMA052***
	MDDDT3530					MDMA102***			MHMA102***
E-frame	MDDDT5540	MAMA082***			MSMA102***	MDMA152***	MGMA092***	MFMA152***	MHMA152***
					MSMA152***				
F-frame	MEDDT7364				MSMA202***	MDMA202***		MFMA252***	MHMA202***
	MFDDTA390				MSMA302***	MDMA302***	MGMA202***		MHMA302***
G-frame	MFDDTB3A2				MSMA402***	MDMA402***	MGMA302***	MFMA452***	MHMA402***
					MSMA502***	MDMA502***	MGMA452***		MHMA502***
	MGDDTC3B4					MDMA752***	MGMA602***		MHMA752***

Refer to page, A4-13, Table of Part Numbers and Options as well.

Driver/Dimensions

Frame A

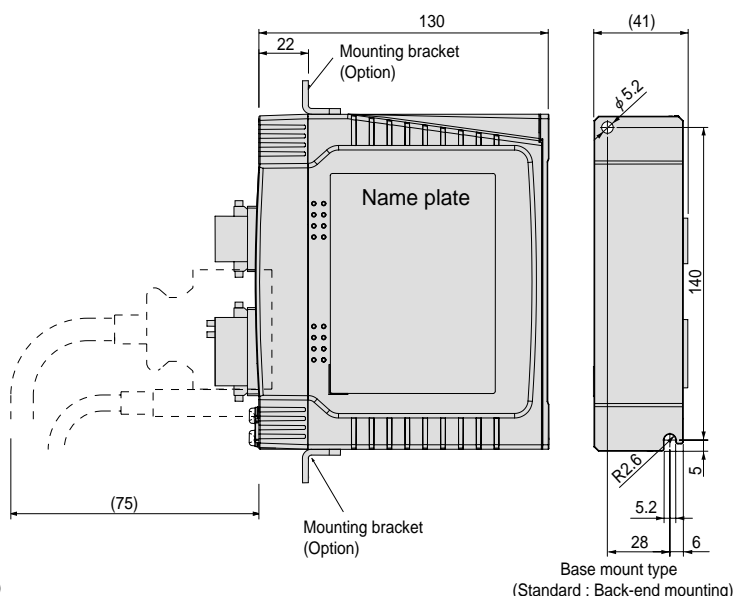
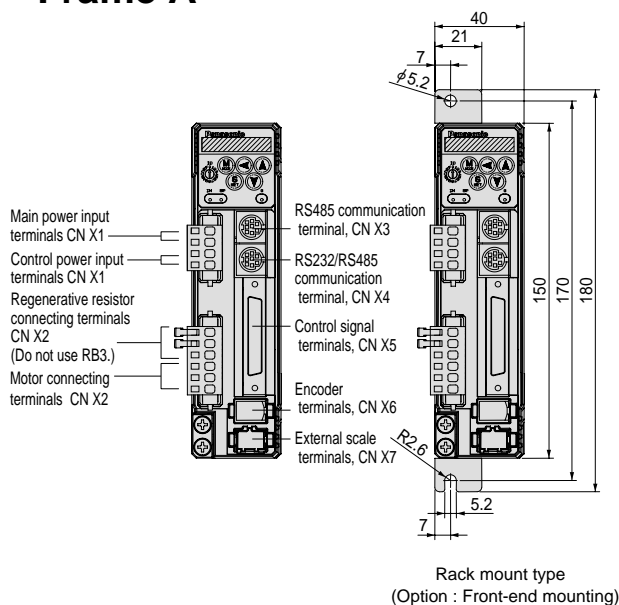

Connector at driver side

Connector sign	Connector type	Manufacturer
CNX7	53460-0629 (or equivalent)	Molex Inc.
CNX6	53460-0629 (or equivalent)	Molex Inc.
CNX5	529865079 (or equivalent)	Molex Inc.
CNX4	MD-S8000-10 (or equivalent)	J.S.T. Mfg.Co., Ltd.
CNX3	MD-S8000-10 (or equivalent)	J.S.T. Mfg.Co., Ltd.
CNX2	S06B-F32SK-GGXR (or equivalent)	J.S.T. Mfg.Co., Ltd.
CNX1	S04B-F32SK-GGXR (or equivalent)	J.S.T. Mfg.Co., Ltd.

Connector at Power Supply and Motor side

Connector sign	Connector type	Manufacturer
CNX2	06JFAT-SAXGF (or equivalent)	J.S.T. Mfg.Co., Ltd.
CNX1	04JFAT-SAXGF (or equivalent)	J.S.T. Mfg.Co., Ltd.

Mass 0.8kg

Frame B

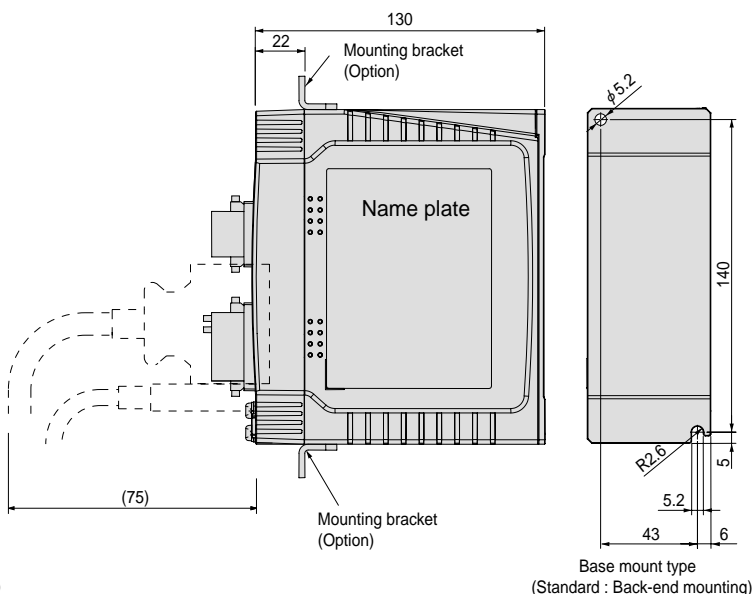
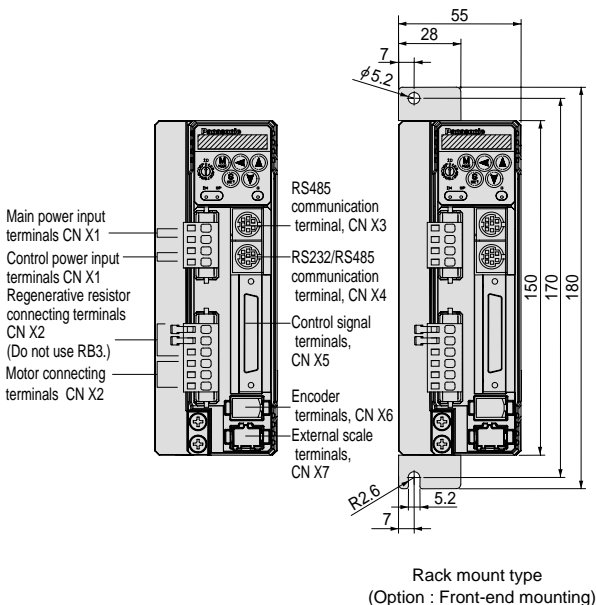

Connector at driver side

Connector sign	Connector type	Manufacturer
CNX7	53460-0629 (or equivalent)	Molex Inc.
CNX6	53460-0629 (or equivalent)	Molex Inc.
CNX5	529865079 (or equivalent)	Molex Inc.
CNX4	MD-S8000-10 (or equivalent)	J.S.T. Mfg.Co., Ltd.
CNX3	MD-S8000-10 (or equivalent)	J.S.T. Mfg.Co., Ltd.
CNX2	S06B-F32SK-GGXR (or equivalent)	J.S.T. Mfg.Co., Ltd.
CNX1	S04B-F32SK-GGXR (or equivalent)	J.S.T. Mfg.Co., Ltd.

Connector at Power Supply and Motor side

Connector sign	Connector type	Manufacturer
CNX2	06JFAT-SAXGF (or equivalent)	J.S.T. Mfg.Co., Ltd.
CNX1	04JFAT-SAXGF (or equivalent)	J.S.T. Mfg.Co., Ltd.

Mass 1.1kg

Driver/Dimensions

Frame C

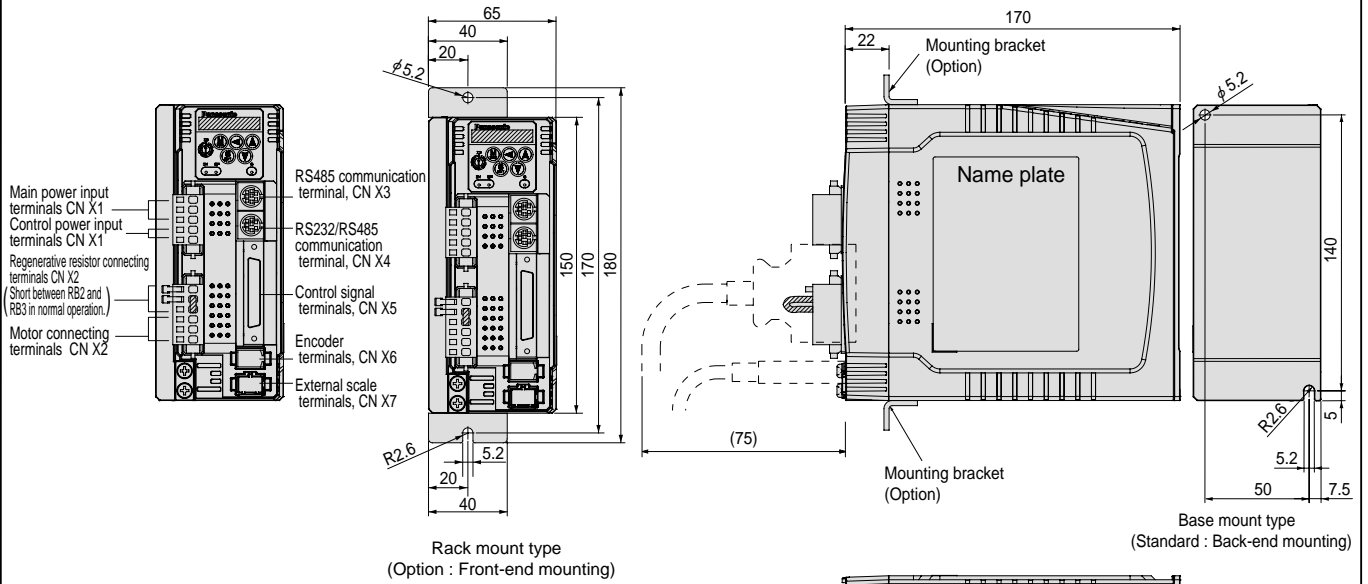

Connector at driver side

Connector sign	Connector type	Manufacturer
CNX7	53460-0629 (or equivalent)	Molex Inc.
CNX6	53460-0629 (or equivalent)	Molex Inc.
CNX5	529865079 (or equivalent)	Molex Inc.
CNX4	MD-S8000-10 (or equivalent)	J.S.T. Mfg.Co., Ltd.
CNX3	MD-S8000-10 (or equivalent)	J.S.T. Mfg.Co., Ltd.
CNX2	S06B-F32SK-GGXR (or equivalent)	J.S.T. Mfg.Co., Ltd.
CNX1	S05B-F32SK-GGXR (or equivalent)	J.S.T. Mfg.Co., Ltd.

Connector at Power Supply and Motor side

Connector sign	Connector type	Manufacturer
CNX2	06JFAT-SAXGF (or equivalent)	J.S.T. Mfg.Co., Ltd.
CNX1	05JFAT-SAXGF (or equivalent)	J.S.T. Mfg.Co., Ltd.

Mass 1.5kg

Frame D

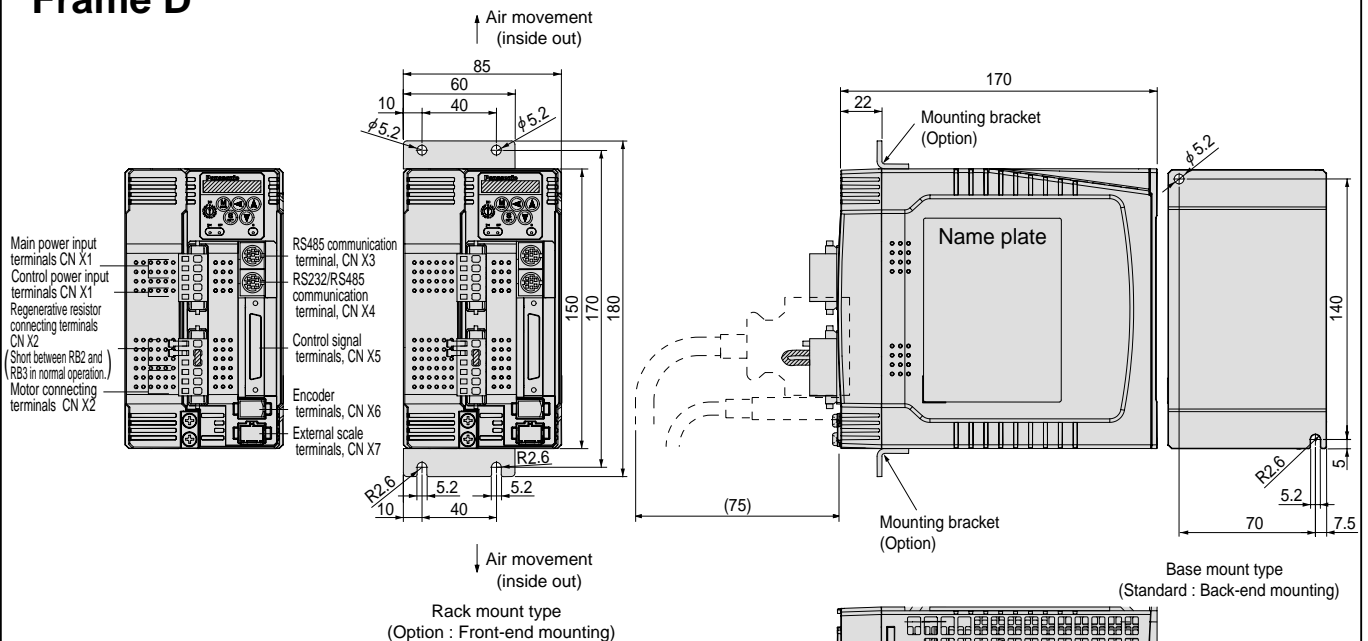

Connector at driver side

Connector sign	Connector type	Manufacturer
CNX7	53460-0629 (or equivalent)	Molex Inc.
CNX6	53460-0629 (or equivalent)	Molex Inc.
CNX5	529865079 (or equivalent)	Molex Inc.
CNX4	MD-S8000-10 (or equivalent)	J.S.T. Mfg.Co., Ltd.
CNX3	MD-S8000-10 (or equivalent)	J.S.T. Mfg.Co., Ltd.
CNX2	S06B-F32SK-GGXR (or equivalent)	J.S.T. Mfg.Co., Ltd.
CNX1	S05B-F32SK-GGXR (or equivalent)	J.S.T. Mfg.Co., Ltd.

Connector at Power Supply and Motor side

Connector sign	Connector type	Manufacturer
CNX2	06JFAT-SAXGF (or equivalent)	J.S.T. Mfg.Co., Ltd.
CNX1	05JFAT-SAXGF (or equivalent)	J.S.T. Mfg.Co., Ltd.

Mass 1.7kg

Frame E

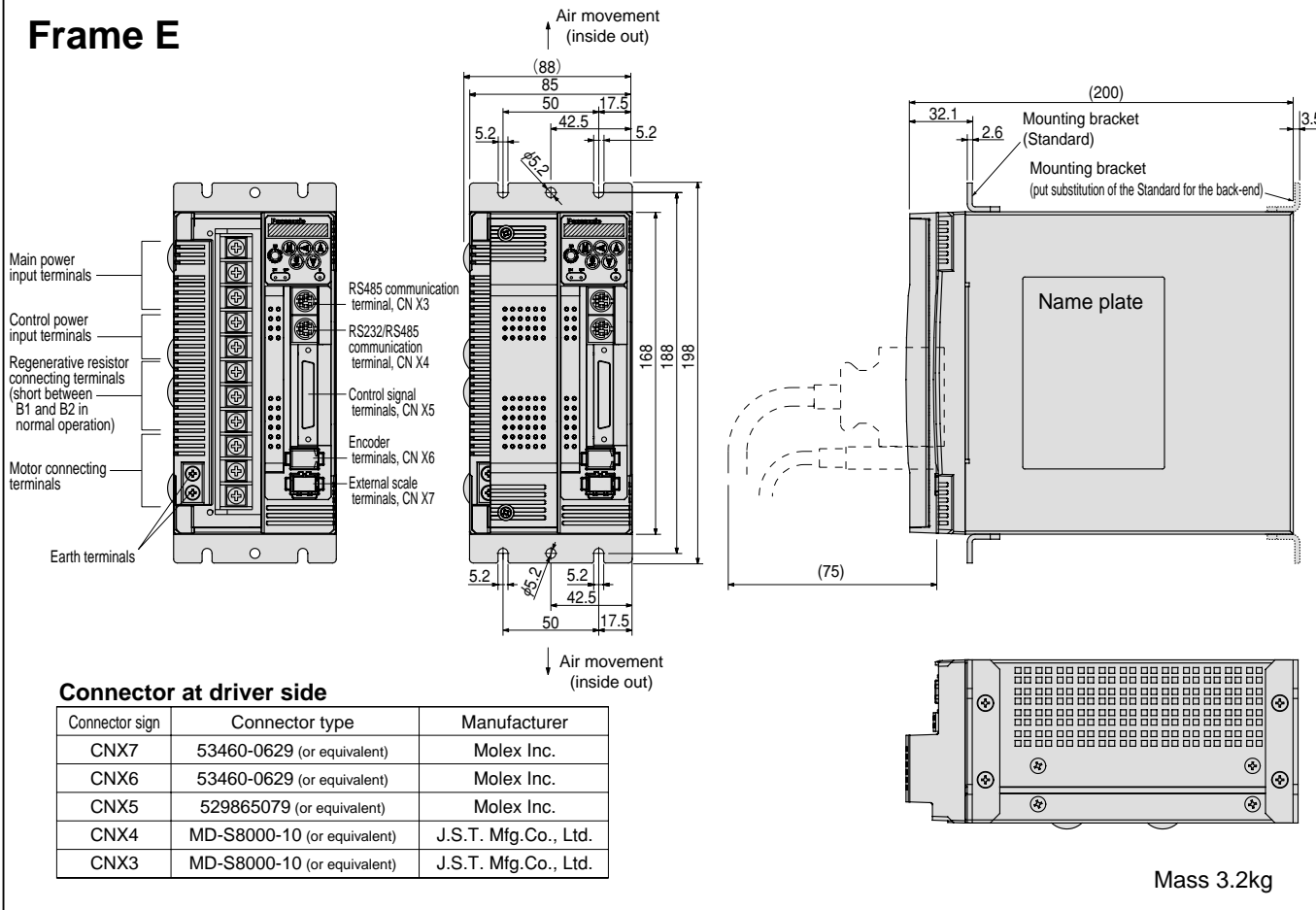

Frame F

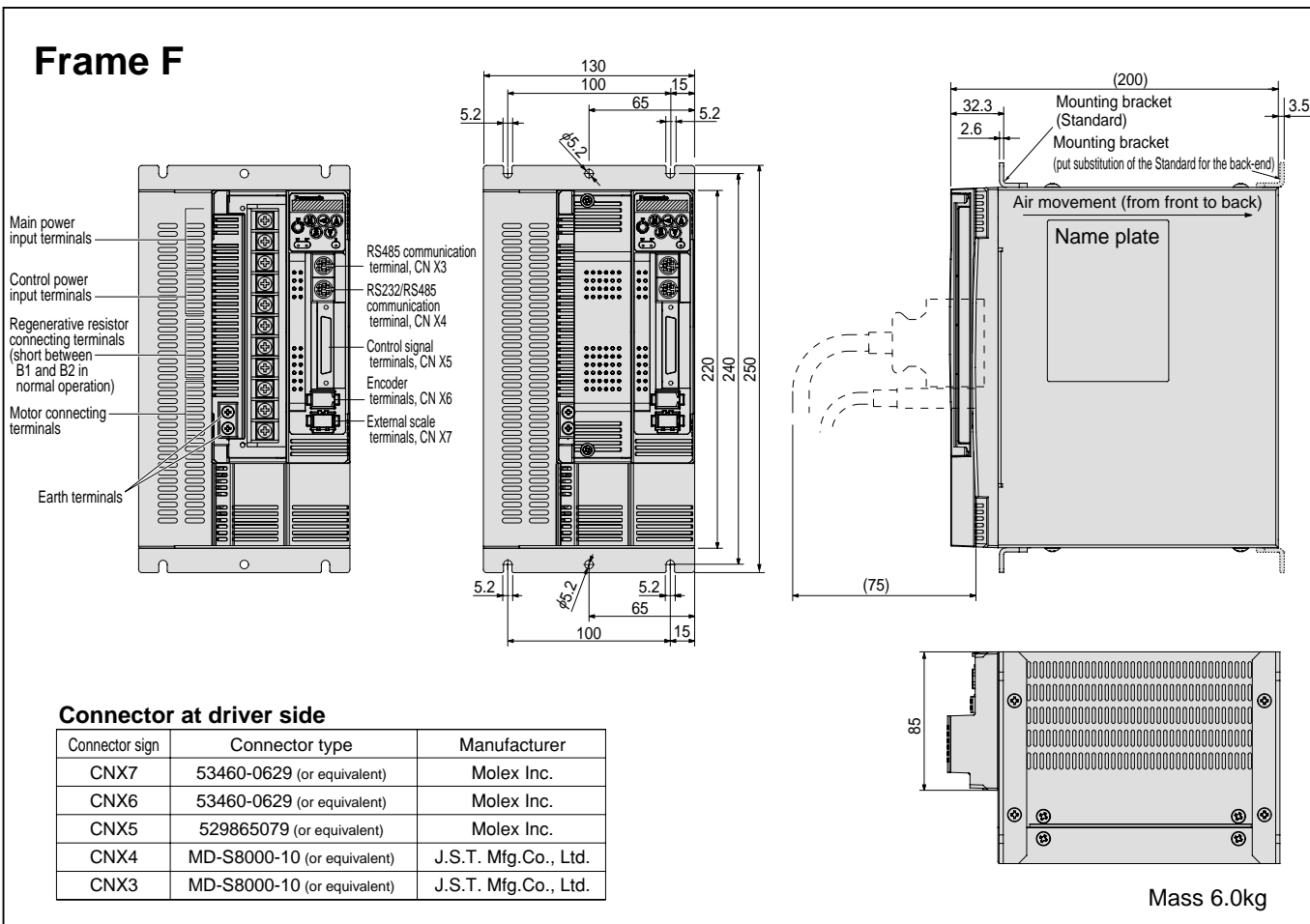

Driver/Dimensions

Frame G

[Terminal block cover B opened]

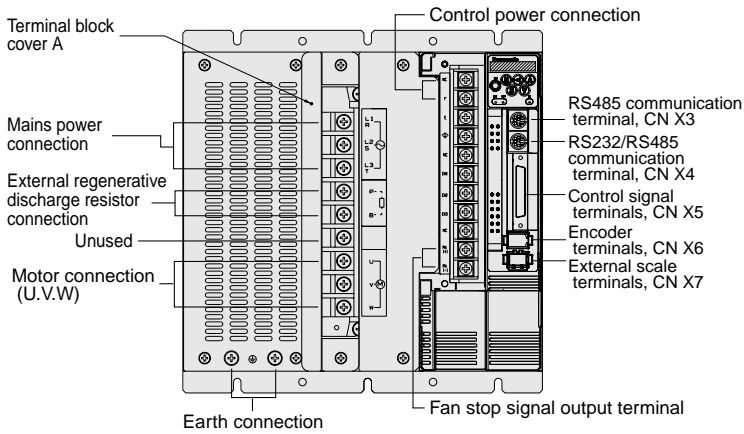

[Terminal block cover B closed]

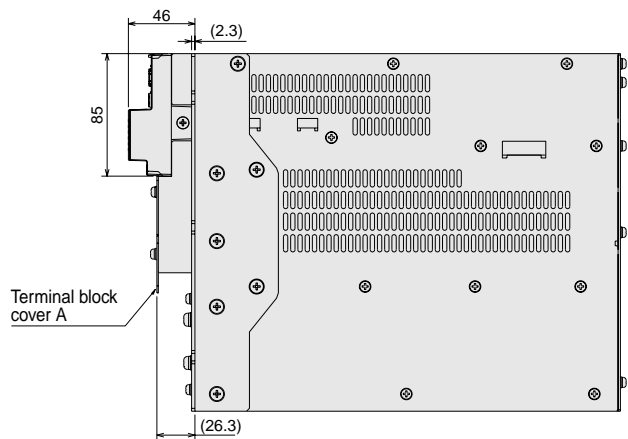
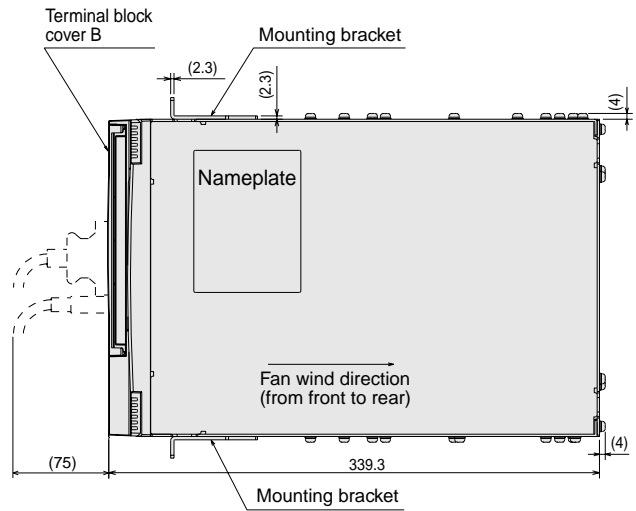
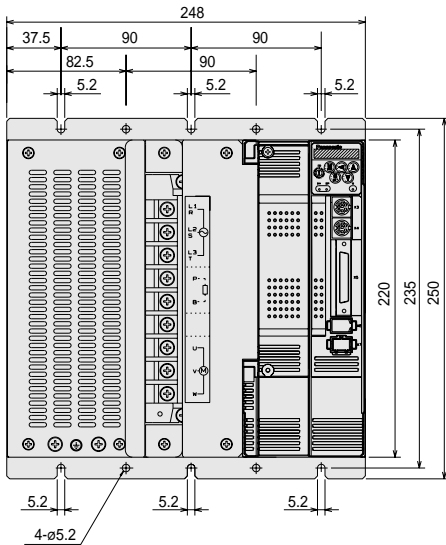

Connector at driver side

Connector sign	Connector type	Manufacturer
CNX7	53460-0629 (or equivalent)	Molex Inc.
CNX6	53460-0629 (or equivalent)	Molex Inc.
CNX5	529865079 (or equivalent)	Molex Inc.
CNX4	MD-S8000-10 (or equivalent)	J.S.T. Mfg.Co., Ltd.
CNX3	MD-S8000-10 (or equivalent)	J.S.T. Mfg.Co., Ltd.

Mass 17.0kg

MEMO

Lined writing area consisting of horizontal lines and a dotted margin line at the top and bottom.



MINAS A4 Driver / Dimensions

I/O Command Type Servo Motor Inherits Strongest Servo Core

MINAS A4P Series



Achieves System Simplification and Cost Reduction

1. Built-in NC Functions

- NC functions allow positioning by I/O command only.
- A target can be positioned (by teaching) without complicated pulse calculations.
- In addition to travel distances, point tables combine 16 types of preset speeds, linear acceleration/deceleration or S-shaped acceleration/deceleration, and 4 types of acceleration and deceleration.
- Two types of continuous operations are available depending on required machine specifications; continuous positioning with a temporary stop at any point and a combined block operation without a temporary stop.
- Sequential operation can be set to execute a maximum of 60 positioning points automatically.
- 8 types of homing operation modes are available. If a bumping homing is selected, simplified return-to-origin can be executed without any origin sensor.

2. Neither a positioning unit nor a pulse generator is required

- A maximum of 60 positioning points can be stored. No complicated programming is required as before.
- Positioning points can be specified as absolute positions or relative positions.
- Positioning can be performed directly at an absolute position without requiring homing operation by using the MINAS A4P as an absolute encoder in combination with a motor equipped with a 17-bit absolute/incremental encoder.

MINAS A4P Series

Contents

● Features	A4-27
● Details of Features	A4-29
● List of Specifications	A4-33
● Model Designation	A4-34
● Wiring Example	A4-35
● Table of Part Numbers and Options	A4-37
● Driver	
<Common Specifications>	A4-39
<Standard Wiring Example of Main Circuit>	A4-41
<Encoder Wiring Diagram>	A4-43
<Standard Wiring Example of Control Circuit Standard>	A4-44
<Table of Applicable Motors>	A4-44
<Dimensions>	A4-45
● Motor	
<Ratings/Specifications/Torque Characteristics>	A4-49
MAMA	A4-49
MSMD	A4-51
MQMA	A4-59
MSMA	A4-63
MDMA	A4-67
MGMA	A4-73
MFMA	A4-77
MHMA	A4-81
<Dimensions>	A4-87
MAMA	A4-87
MSMD	A4-88
MQMA	A4-90
MSMA	A4-91
MDMA	A4-93
MGMA	A4-96
MFMA	A4-99
MHMA	A4-101
● Motor with Gear Reducer/MSMD	
<General Specifications>	A4-105
<Ratings/Specifications>	A4-106
<Torque Characteristics>	A4-107
<Dimensions>	A4-108
● Conformity to CE and UL	A4-109
● IP65 Rating	A4-112
● Options	A4-113
● Recommended components	A4-127

Remarks :Instruction manual is available as an option as
 Japanese version : DV0P4480 and
 English version : DV0P4490

Details of Features

Inherits high performance and advanced functioning

1. Further Adjustment-Free Operation

High-functionality Real-Time Auto-Gain Tuning

- Corresponds to even variation of load inertia. Offers real automatic gain tuning to low and high stiffness machines with a combination of an adaptive filter.
- Supports the vertical axis application where the load torque is different in rotational direction.
- Prevents the machine from over-traveling during automatic gain tuning with software limit protective function.

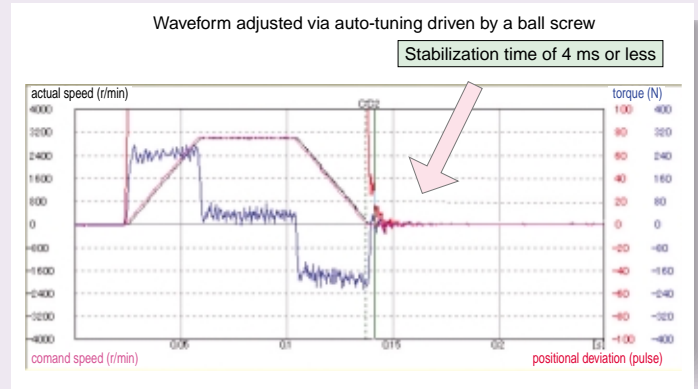

2. Further High-Speed and High-Response

Velocity response (bandwidth) of 1kHz

- Implementation of Instantaneous Velocity Observer realizes a detection of motor speed with higher speed and higher resolution.

*) In case of high stiffness machine

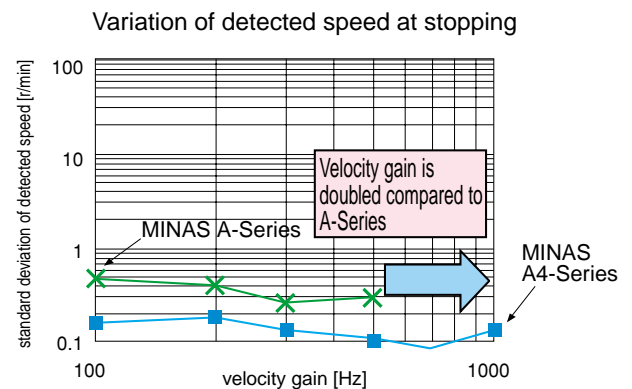
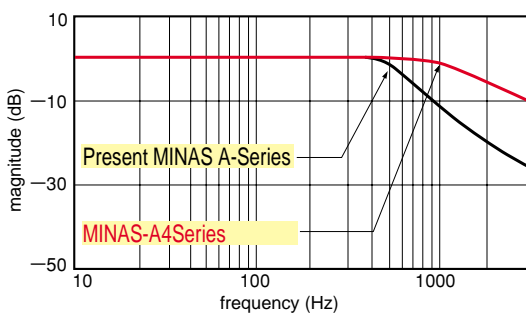

High-functionality Real-Time Auto-Gain Tuning

- Supports the low stiffness machine of belt-driven and the high stiffness machine of short stroke ball screw driven, and enables to realize high-speed positioning with high-functionality real-time auto-gain tuning.

3. Further Reduction of Vibration

Adaptive filter

- Makes the notch filter frequency automatically follow the machine resonance frequency.
- Suppression of "Judder" noise of the machine can be expected which is caused by variation of the machines or resonance frequency due to aging.

2-channel notch filters

- 2-channel notch filters are equipped in the driver independent from adaptive filter.
- You can set up both frequency and width for each of 2 filters, and set up frequency in unit of 1Hz.
- Suppression of "Judder" noise of the machine which has multiple resonance points can be expected

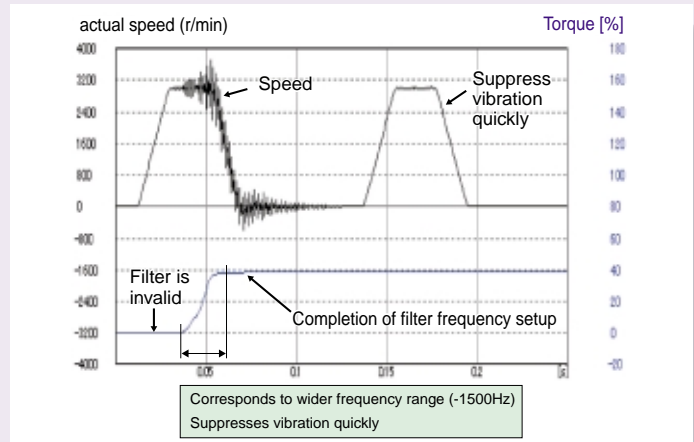

Effect of notch filter

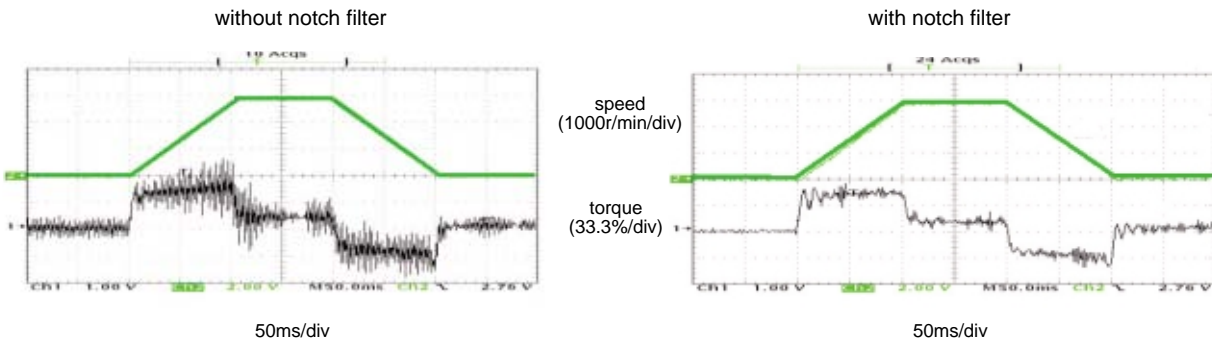

Damping control

- 2-channel damping filters are equipped in this driver. You can suppress vibration occurring at both starting and stopping in low stiffness machine, by manually setting up vibration frequency in 0.1Hz unit.
- You can also switch the vibration frequency set by 2-channel with rotating direction or with an external input to correspond to the variation of vibration frequency caused by the machine position.
- Easy setup with entry of only frequency and filter value. Improper setup values do not result in unstable operation

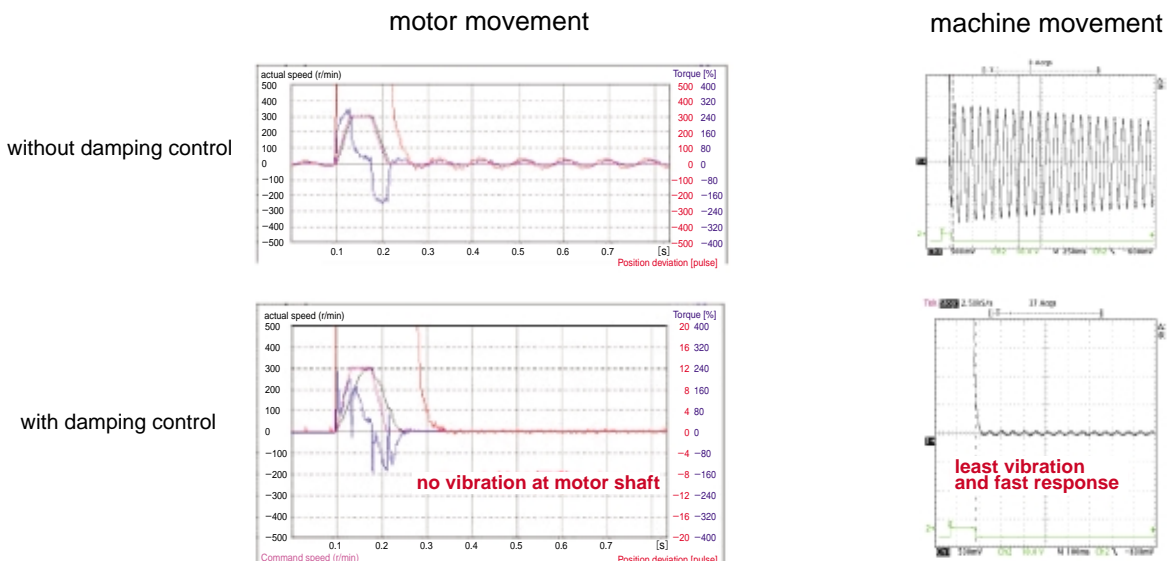

4. Further Flexibility and Multiplicity

Dedicated Console (DV0P4420)

- Enables easy parameter setting/changing, control state monitoring, status/error log viewing, and parameter saving/loading.
- Makes it easy to move a target position, set a positioning point and perform teaching.
- Can select and display 16 types of operation data including motor rotational speed and torque in the monitor mode.

Control Mode

- Makes it possible to select position control via the motor's internal encoder or fully-closed control based on an external scale.

Analog Monitor Terminal

- "Motor rotational speed", "Command speed", "torque command" and "positional deviation" can be observed by oscilloscope through the analog monitor pin at the front panel of the amplifier.

Trial run (JOG)

- Features the function for trial (JOG) run through console (option) without connecting to a host controller.
- You can shorten the machine setup time.

Full-closed control (High precision positioning)

- Features the full-closed control of position and velocity, using the signals from linear scale installed on the load side and high resolution encoder.

Note) Applicable external linear scales are as follows,

AT500 series by Mitutoyo (Resolution 0.05[μ m], max, speed 2[m/s])

ST771 series by Mitutoyo (Resolution 0.5[μ m], max, speed 2[m/s])

- Best suits to high precision machines.

Inrush current suppressing function

- Inrush suppressing resistor is equipped in this driver, which prevents the circuit breaker shutdown of the power supply caused by inrush current at power-on.
- Prevents unintentional shutdown of the power supply circuit breaker

Regeneration discharging function

- Discharges the regenerative energy with resistor, which energy is generated while stopping the load with large moment of inertia, or use in up-down operation, and is returned to the driver from the motor.
- No regeneration discharge resistor is built-in to Frame A driver (MADDT1105P type.) and Frame B driver (MBDDT2210P type.), and we recommend you to connect optional regenerative resistor.
- Regenerative resistor is built-in to Frame C to F drivers, however, connection of the optional regenerative resistor bring you further regenerative capability.

Built-in dynamic brake

- You can select the dynamic brake action which short the servo motor windings of U, V and W, at Servo-OFF, CW/CCW over-travel inhibition, power shutdown and trip.
- You can select the action sequence setup depending on the machine requirement.

Setup support software

- With the setup support software, "PANATERM[®]" via RS232 communication port, you can monitor the running status of the driver and set up parameters.

Wave-form graphic function

- With the setup support software, "PANATERM[®]", you can monitor the "Command speed", "Actual speed", "Torque", "Position deviation" and "Positioning complete signal".
 - Helps you to analyze the machine and shorten the setup time
- *Note) Refer to page "F4" for setup support software.

Selectable Torque Limit Value

- A torque limit can be set for each rotational direction.
- According to the specification of the machine, a maximum torque can be set for each rotational direction as necessary.

Built in sequence of bumping homing

- You can select 8 kind of homing mode.

SEMI F47 voltage sag immunity

- Features the function which complies to voltage sag immunity standard of SEMI F47 at no load or light load.
- Useful for semiconductor industry.

Notes)

- 1)Not applicable to single phase, 100V type.
- 2)Verify with the actual machine condition to F47, voltage sag immunity standard.

Frequency analyzing function

- You can confirm the response frequency characteristics of total machine mechanism including the servo motor with the setup support software, "PANATERM[®]"
 - Helps you to analyze the machine and shorten the setup time
- *Note) Refer to page "F4" for setup support software.









■Applicable overseas safety standards



Subject	Standard conformed		
Motor	IEC60034-1	IEC60034-5	UL1004 CSA22.2 NO.100
	EN50178	UL508C	
Motor and driver	EN55011	Radio Disturbance Characteristics of Industrial, Scientific and Medical (ISM) Radio-Frequency Equipment	
	EN61000-6-2	Immunity for Industrial Environments	
	IEC61000-4-2	Electrostatic Discharge Immunity Test	
	IEC61000-4-3	Radio Frequency Electromagnetic Field Immunity Test	
	IEC61000-4-4	Electric High-Speed Transition Phenomenon/Burst Immunity Test	
	IEC61000-4-5	Lightening Surge Immunity Test	
	IEC61000-4-6	High Frequency Conduction Immunity Test	
	IEC61000-4-11	Instantaneous Outage Immunity Test	
			Conforms to Low-Voltage Directives
			Conforms to references by EMC Directives

I E C : International Electrotechnical Commission
 E N : Europaischen Normen
 EMC : Electromagnetic Compatibility
 U L : Underwriters Laboratories
 CSA : Canadian Standards Association

List of Specifications

	Motor series	Rated output (kW)	Rated rotational speed (Max. speed) (r/min)	Rotary encoder		Brake Holding	Gear High precision	CE/UL	Enclosure	Features	Applications
				2500P/r incremental	17bit absolute/incremental						
Ultra low inertia	MAMA 	0.1-0.75 4 models 0.1, 0.2, 0.4 and 0.75	5000 (6000)	○	○	○	—	○	IP65 (Except shaft through hole and connector)	·Small capacity ·Suitable for the machines directly coupled with high speed ball screw and high stiffness and high repetitive application	·SMT machines ·Inserters ·High repetitive positioning application
Low inertia	MSMD 	0.05-0.75 5 models 0.05, 0.1, 0.2, 0.4 and 0.75	3000 (5000) *For 400W/100V and 750W 3000 (4500)	○	○	○	○	○	IP65 (Except shaft through hole and connector)	·Small capacity ·Suitable for all applications	·Inserters ·Belt driven machines ·Unloading robot
	MQMA 	0.1-0.4 3 models 0.1, 0.2, and 0.4	3000 (5000) *For 400W/100V 3000 (4500)	○	○	○	—	○	IP65 (Except shaft through hole and connector)	·Small capacity ·Suitable for flat type and low stiffness machines with belt driven	·SMT machines ·Inserters ·Belt driven machines ·Unloading robot
	MSMA 	1.0-5.0 6 models 1.0,1.5,2.0, 3.0,4.0 and 5.0	3000 (5000) *For 4kW and 5kW 3000 (4500)	○	○	○	—	○	IP65 (Except cannon plug/connector pins)	·Middle capacity ·Suitable for the machines directly coupled with ball screw and high stiffness and high repetitive application	·SMT machines ·Inserter ·Food machines
Middle inertia	MDMA 	1.0-5.0 6 models 1.0,1.5,2.0, 3.0,4.0 and 5.0	2000 (3000)	○	○	○	—	○	IP65 (Except cannon plug/connector pins)	·Middle capacity ·Suitable for low stiffness machines with belt driven	·Belt driven machines ·Conveyers ·Robots
	MGMA 	0.9-4.5 4 models 0.9,2.0, 3.0 and 4.5	1000 (2000)	○	○	○	—	○	IP65 (Except cannon plug/connector pins)	·Middle capacity ·Suitable for machines requiring low speed with high torque	·Belt driven machines ·Conveyers ·Robots
	MFMA 	0.4-4.5 4 models 0.4,1.5, 2.5 and 4.5	2000 (3000)	○	○	○	—	○	IP65 (Except cannon plug/connector pins)	·Middle capacity ·Flat type and suitable for machines with space limitation	·Robots ·Food machines
High inertia	MHMA 	0.5-5.0 7 models 0.5,1.0,1.5, 2.0,3.0,4.0 and 5.0	2000 (3000)	○	○	○	—	○	IP65 (Except cannon plug/connector pins)	·Middle capacity ·Suitable for low stiffness machines with belt driven, and large load moment of inertia	·Belt driven machines ·Conveyers ·Robots

Motor is sharing with A4 series

Model Designation

■ Servo Motor

M S M D 5 A Z S 1 S * *

Symbol	Type
MAMA	Ultra low inertia (100W-750W)
MSMD	Low inertia (50W-750W)
MQMA	Low inertia (100W-400W)
MSMA	Low inertia (1.0kW-5.0kW)
MDMA	Middle inertia (1.0kW-5.0kW)
MGMA	Middle inertia (900W-4.5kW)
MFMA	Middle inertia (400W-4.5kW)
MHMA	High inertia (500W-5.0kW)

Motor rated output

Symbol	Rated output	Symbol	Rated output
5A	50W	15	1.5kW
01	100W	20	2.0kW
02	200W	25	2.5kW
04	400W	30	3.0kW
05	500W	40	4.0kW
08	750W	45	4.5kW
09	900W	50	5.0kW
10	1.0kW		

Design order
1 : Standard

Rotary encoder specifications

Symbol	Format	Pulse counts	Resolution	Wires
P	Incremental	2500P/r	10000	5
S	Absolute/ Incremental common	17bit	131072	7

Voltage specifications

Symbol	Specifications
1	100V
2	200V
Z	100V/200V common(50W only)

Special specifications

Motor structure

MSMD(standard stock), MQMA(build to order)

Symbol	Shaft		Holding brake		Oil seal	
	Round	Key-way, center tap	without	with	without	with*
A	●		●		●	
B	●			●	●	
S		●	●		●	
T		●		●	●	

* Motor with oil seal is manufactured by order.

MSMA, MDMA, MGMA, MFMA, MHMA

Symbol	Shaft		Holding brake		Oil seal	
	Round	Key-way	without	with	without	with
C	●		●			●
D	●			●	●	●
G		●	●			●
H		●		●		●

Products are standard stock items or build to order items. See index (page F31).

MAMA

Symbol	Shaft		Holding brake		Oil seal	
	Round	Key-way	without	with	without	with
A	●		●		●	
B	●			●	●	
E		●	●		●	
F		●		●	●	

Products are standard stock items or build to order items. See index (page F31).

See page, A4-49 for motor specifications

■ Motor with reduction gear

M S M D 0 1 1 P 3 1 N

Symbol	Type
MSMD	Low inertia (100W-750W)

Motor rated output

Symbol	Rated output
01	100W
02	200W
04	400W
08	750W

Voltage specifications

Symbol	Specifications
1	100V
2	200V

Gear reduction ratio, gear type

Symbol	Gear reduction ratio	Motor output (W)				Gear type
		100	200	400	750	
1N	1 / 5	●	●	●	●	For high accuracy
2N	1 / 9	●	●	●	●	
3N	1 / 15	●	●	●	●	
4N	1 / 25	●	●	●	●	

Motor structure

Symbol	Shaft		Holding brake	
	Key-way	without	without	with
3	●		●	
4	●			●

Rotary encoder specifications

Symbol	Format	Pulse counts	Resolution	Wires
P	Incremental	2500P/r	10000	5
S	Absolute/ Incremental common	17bit	131072	7

See page, A4-105 for motor with gear reducer specifications

■ Servo Driver

M A D D T 1 2 0 5 P * *

Special specifications

Frame symbol

Symbol	Frame
MADD	A4 series, Frame A
MBDD	A4 series, Frame B
MCDD	A4 series, Frame C
MDDD	A4 series, Frame D
MEDD	A4 series, Frame E
MFDD	A4 series, Frame F

Power device Max. current rating

Symbol	Power device Max. current rating
T1	1.0 A
T2	1.5 A
T3	3.0 A
T5	5.0 A
T7	7.5 A
TA	1.0 A
TB	1.5 A

Supply voltage specifications

Symbol	Specifications
1	Single phase, 100V
2	Single phase, 200V
3	3-phase, 200V
5	Single/3-phase, 200V

Current detector current rating

Symbol	Current detector, current rating
05	5 A
07	7.5 A
10	1.0 A
20	2.0 A
30	3.0 A
40	4.0 A
64	6.4 A
90	9.0 A
A2	1.2 A

Interface

Symbol	Specifications
P	I/O Operation

See page, A4-39 for driver specifications

Wiring example

Driver Frame Type Symbol (Frame A, B, C, D)

For details, refer to the Instruction Manual.

●Wiring of main circuit

Circuit Breaker (NFB)

Protects the power lines.
Shuts off the circuit when overcurrent passes.

Noise Filter (NF)

Prevents external noise from the power lines.
And reduces an effect of the noise generated by the servo driver.

Magnetic Contactor (MC)

Turns on/off the main power of the servo driver.
Surge absorber to be used together with this.

Reactor (L)

Reduces harmonic current of the main power.

Pin RB, RB2 and RB3...

- RB2 and RB3 to be kept shorted for normal operation.

- When the internal regenerative resistor capacity has shortage, disconnect between RB2 and RB3, then connect an external regenerative resistor between RB1 and RB2.

Motor	to page A4-49
Driver	to page A4-39
Option	to page A4-113
Recommended equipments	
Parts customer to prepare	

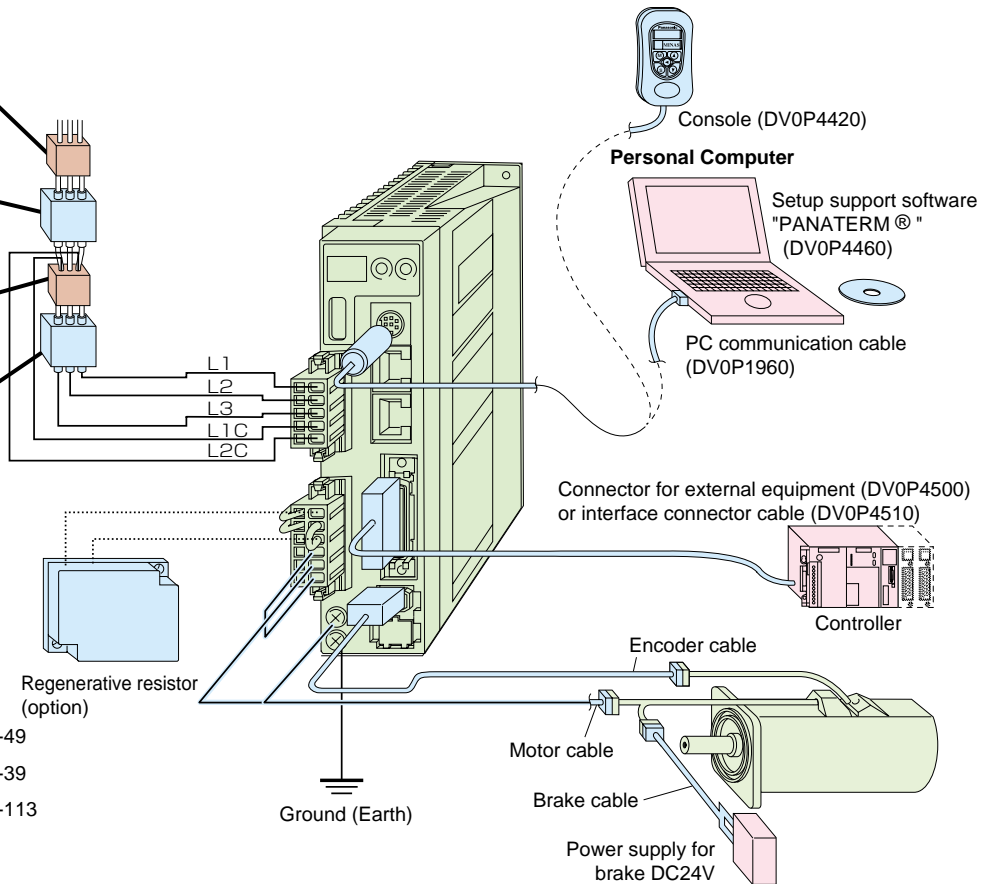

■List of recommended peripheral equipments

Power supply voltage	Applicable motor		Power capacity (at rated load)	Circuit breaker (rated current)	Noise filter	Surge absorber	Noise filter (signal)	Magnetic contactor (Contact)	Cable diameter (Main circuit)	Cable diameter (control circuit)	Connector	
	Series	Out put										
Single phase, 100V	MSMD	50W	Approx. 0.4kVA	DVOP 4170				BMFT61041N (3P+1a)	0.75mm ² to 2.0mm ² AWG14 to 18	0.75mm ² AWG18	Connection to exclusive connector	
		100W										
	MQMA	200W										Approx. 0.5kVA
		400W										
Single phase, 200V	MSMD	50W	BBC 2101N (10A)	DVOP 4190	DVOP 1460		BMFT61541N (3P+1a)	0.75mm ² to 2.0mm ² AWG14 to 18	0.75mm ² AWG18	Connection to exclusive connector		
		100W										
	MQMA	100W									Approx. 0.3kVA	
		200W										Approx. 0.5kVA
	MSMD	200W		Approx. 0.5kVA	DVOP 4170			BMFT61542N (3P+1a)	0.75mm ² to 2.0mm ² AWG14 to 18	0.75mm ² AWG18	Connection to exclusive connector	
		400W										Approx. 0.9kVA
	MQMA	400W		Approx. 0.9kVA					0.75mm ² to 2.0mm ² AWG14 to 18	0.75mm ² AWG18	Connection to exclusive connector	

Power supply voltage	Applicable motor		Power capacity (at rated load)	Circuit breaker (rated current)	Noise filter	Surge absorber	Noise filter (signal)	Magnetic contactor (Contact)	Cable diameter (Main circuit)	Cable diameter (control circuit)	Connector									
	Series	Out put																		
Single/3-phase, 200V	MAMA	400W	Approx. 0.9kVA	BBC 3151N (15A)	DVOP 4180			BMFT61542N (3P+1a)	0.75mm ² to 2.0mm ² AWG14 to 18	0.75mm ² AWG18	Connection to exclusive connector									
		MFMA																		
	MHMA	500W										Approx. 1.1kVA								
		MSMD											Approx. 1.3kVA							
	MAMA	750W										Approx. 1.6kVA								
	MDMA	1.0kW											Approx. 1.8kVA	DVOP 1450	DVOP 1460			BMFT61842N (3P+1a)	2.0mm ² AWG14	0.75mm ² AWG18
		MHMA																		
	MGMA	900W										Approx. 2.3kVA	DVOP 4220							Connection to exclusive connector
	MSMA	1.0kW																		
	MDMA	1.5kW										Approx. 2.3kVA	BBC 3201N (20A)							Connection to exclusive connector
	MFMA																			
	MHMA																			

● Select a single and 3-phase common specifications corresponding to the power supplies.

● Listed circuit breaker and magnetic contactor are manufactured by Matsushita Electric Works.

To conform to EC Directives, install a circuit breaker which conforms to IEC and UL Standards (UL Listed and ® marked) between noise filter and power supply without fail.

● For details of noise filter, refer to Page A4-110.

<Remarks>

- Select a circuit breaker and noise filter which match to the capacity of power supply (including a load condition).
- Terminal block and earth terminals
Use a copper conductor cables with temperature rating of 60°C or higher.
Earth terminals for Frame A to D are M4 and M5 for Frame E to F.
Larger tightening torque for screws than the max. value (M4 : 1.2 N · m, M5 : 2.0 N · m) may damage the terminal block.
- Use an earth cable with diameter of 2.0mm² (AWG14) or larger for 50W to 1.5kW, 3.5mm² (AWG12) or larger for 3kW to 4kW and 5.3mm² (AWG10) or larger for 4.5kW to 5kW.
- Use the attached exclusive connector for A to D-frame, and maintain the peeled off length of 8-9mm.
- Tighten the screws of the connector, CN X5 for the host controller with the torque of 0.3 to 0.35 N · m.
- Larger torque than 0.35 N · m may damage the connector at the driver side.

Driver Frame Type Symbol (Frame E, F)

For details, refer to the Instruction Manual.

●Wiring of main circuit

Circuit Breaker (NFB)

Protects the power lines.
Shuts off the circuit when overcurrent passes.

Noise Filter (NF)

Prevents external noise from the power lines.
And reduces an effect of the noise generated by the servo driver.

Magnetic Contactor (MC)

Turns on/off the main power of the servo driver.
Surge absorber to be used together with this.

Reactor (L)

Reduces harmonic current of the main power.

Pin RB, RB2 and RB3...

· B1 and B2 to be kept shorted for normal operation.

· When the internal regenerative resistor capacity has shortage, disconnect between B1 and B2, then connect an external regenerative resistor between P and B2.

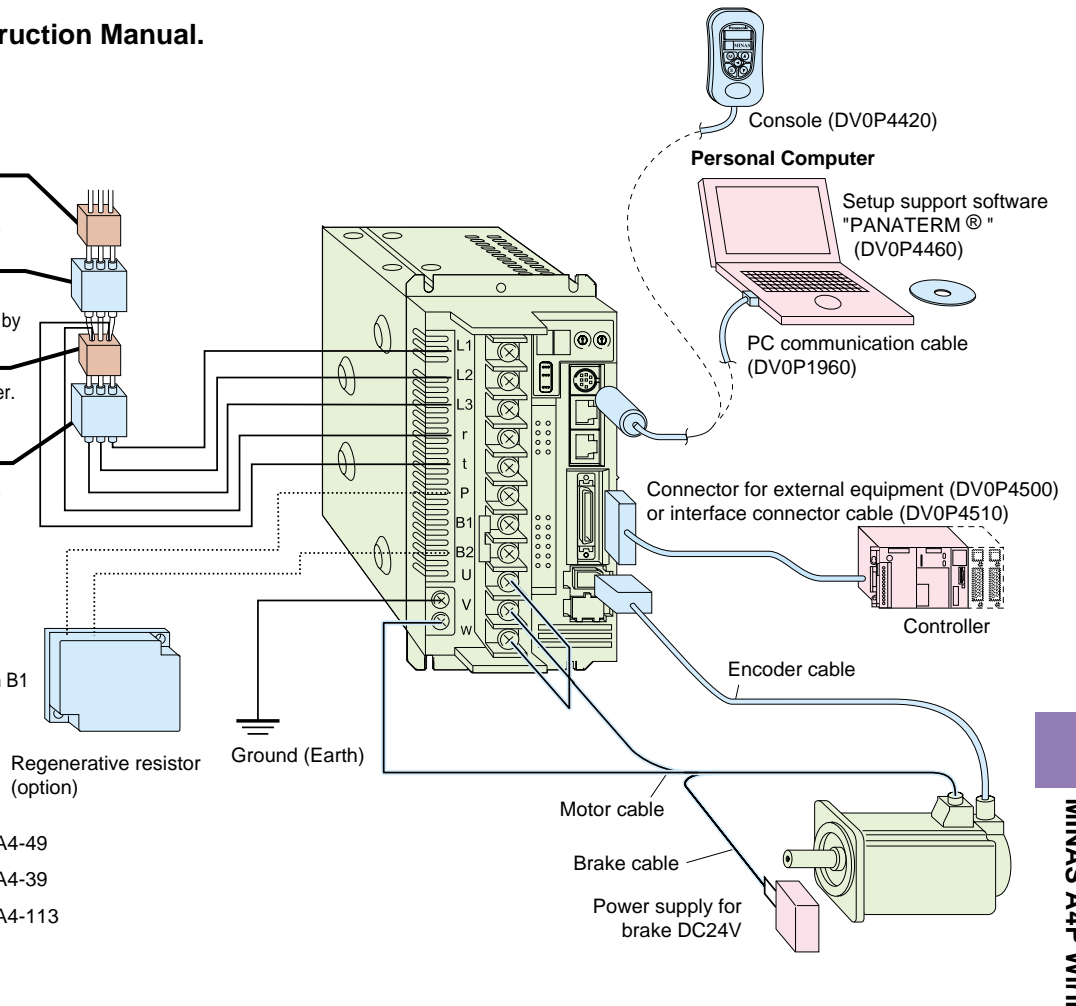

Motor	to page A4-49
Driver	to page A4-39
Option	to page A4-113
Recommended equipments	
Parts customer to prepare	

■List of recommended peripheral equipments

Power supply voltage	Applicable motor Series	Out put	Power capacity (rated load)	Circuit breaker (rated current)	Noise filter	Surge absorber	Noise filter (signal)	Magnetic contactor (Contact)	Cable diameter (Main circuit)	Cable diameter (control circuit)	Connector					
3-phase, 200V	MSMA	2.0kW	Approx. 3.3kVA	BBC 3301N (30A)	DVOP 4220			BMF6352N (3P+2a2b)	2.0mm ² AWG14	0.75mm ² AWG18	Connection to terminal block M5					
	MDMA															
	MHMA															
	MFMA	2.5kW	Approx. 3.8kVA									DVOP 1450	DVOP 1460			3.5mm ² AWG12
	MGMA															
	MSMA															
	MDMA	3.0kW	Approx. 4.5kVA	BBC 3501N (50A)	DVOP 3410			5.3mm ² AWG10								
	MHMA															
	MGMA															
	MSMA	4.0kW	Approx. 6.0kVA						DVOP 3410							
	MDMA															
	MHMA															
	MFMA	4.5kW	Approx. 6.8kVA	DVOP 3410												
	MGMA															
MSMA																
MDMA	5.0kW	Approx. 7.5kVA	DVOP 3410													
MHMA																

- Select a single and 3-phase common specifications corresponding to the power supplies.
- Listed circuit breaker and magnetic contactor are manufactured by Matsushita Electric Works.

To conform to EC Directives, install a circuit breaker which conforms to IEC and UL Standards (UL Listed and ® marked) between noise filter and power supply without fail.

- For details of noise filter, refer to Page A4-110.

<Remarks>

- Select a circuit breaker and noise filter which match to the capacity of power supply (including a load condition).
- Terminal block and earth terminals
Use a copper conductor cables with temperature rating of 60°C or higher.
Earth terminals for Frame A to D are M4 and M5 for Frame E to F.
Larger tightening torque for screws than the max. value (M4 : 1.2 N · m, M5 : 2.0 N · m) may damage the terminal block.
- Use an earth cable with diameter of 2.0mm² (AWG14) or larger for 50W to 1.5kW, 3.5mm² (AWG12) or larger for 3kW to 4kW and 5.3mm² (AWG10) or larger for 4.5kW to 5kW.
- Use the attached exclusive connector for Frame A to D and maintain the peeled off length of 8-9mm.
- Tighten the screws of the connector, CN X5 for the host controller with the torque of 0.3 to 0.35 N · m.
- Larger torque than 0.35N · m may damage the connector at the driver side.

Table of Part Numbers and Options

Power supply	Motor series	Rated rotational speed (r/min)	Output (W)	2500P/r, Incremental			17bit, Absolute/Incremental common				2500P/r and 17bit common			
				Motor Note) 1	Rating/Spec. (page)	Encoder cable Note) 2	Motor Note) 1	Rating/Spec. (page)	Encoder cable Note) 2	Encoder cable Note) 2	Driver	Frame symbol		
Single phase 200V	MAMA Ultra	5000	100	MAMA012P1	A4-49		MAMA012S1	A4-49			MADDT1207P	A-frame		
			200	MAMA022P1	A4-49		MAMA022S1	A4-49			MBDDT2210P	B-frame		
			400	MAMA042P1	A4-49		MAMA042S1	A4-49			MCDDT3520P	C-frame		
			750	MAMA082P1	A4-49		MAMA082S1	A4-49			MDDDT5540P	D-frame		
			3-phase, 200V	low inertia	400	MAMA042P1	A4-49		MAMA042S1	A4-49			MCDDT3520P	C-frame
					750	MAMA082P1	A4-49		MAMA082S1	A4-49			MDDDT5540P	D-frame
Single phase 100V	MSMD Low inertia	5000	50	MSMD5AZP1	A4-51		MSMD5AZS1	A4-51			MADDT1105P	A-frame		
			100	MSMD011P1	A4-51		MSMD011S1	A4-51			MADDT1107P			
			200	MSMD021P1	A4-53		MSMD021S1	A4-53			MBDDT2110P	B-frame		
			400	MSMD041P1	A4-53		MSMD041S1	A4-53			MCDDT3120P	C-frame		
	MQMA Low inertia Flat	5000	100	MQMA011P1	A4-59	MFCEA 0* * 0EAM	MQMA011S1	A4-59	MFCEA 0* * 0EAE	MFCEA 0* * 0EAD	MADDT1107P	A-frame		
			200	MQMA021P1	A4-59		MQMA021S1	A4-59			MBDDT2110P	B-frame		
			400	MQMA041P1	A4-59		MQMA041S1	A4-59			MCDDT3120P	C-frame		
			750	MQMA082P1	A4-59		MQMA082S1	A4-59			MDDDT5540P	D-frame		
Single phase 200V	MSMD Low inertia	3000	50	MSMD5AZP1	A4-55		MSMD5AZS1	A4-55			MADDT1205P	A-frame		
			100	MSMD012P1	A4-55		MSMD012S1	A4-55			MADDT1207P			
			200	MSMD022P1	A4-57		MSMD022S1	A4-57			MBDDT2210P	B-frame		
			400	MSMD042P1	A4-57		MSMD042S1	A4-57			MCDDT3520P	C-frame		
			750	MSMD082P1	A4-57		MSMD082S1	A4-57			MDDDT5540P	D-frame		
	MQMA Low inertia Flat	3000	100	MQMA012P1	A4-61		MQMA012S1	A4-61			MADDT1205P	A-frame		
			200	MQMA022P1	A4-61		MQMA022S1	A4-61			MADDT1207P			
			400	MQMA042P1	A4-61		MQMA042S1	A4-61			MBDDT2210P	B-frame		
	MSMA Low inertia	3000	1000	MSMA102P1	A4-63		MSMA102S1	A4-63			MDDDT5540P	D-frame		
			1500	MSMA152P1	A4-63		MSMA152S1	A4-63			MDDDT3530P			
	MDMA Middle inertia	2000	1000	MDMA102P1	A4-67		MDMA102S1	A4-67			MDDDT5540P	D-frame		
			1500	MDMA152P1	A4-67		MDMA152S1	A4-67			MDDDT3530P			
	MGMA Middle inertia	1000	900	MGMA092P1	A4-73	MFCEA 0* * 0ESD	MGMA092S1	A4-73	MFCEA 0* * 0ESE	MFCEA 0* * 0ESD	MDDDT5540P	D-frame		
			400	MFMA042P1	A4-77		MFMA042S1	A4-77			MCDDT3520P		C-frame	
	MFMA Middle inertia	2000	1500	MFMA152P1	A4-77		MFMA152S1	A4-77			MDDDT5540P	D-frame		
			500	MHMA052P1	A4-81		MHMA052S1	A4-81			MCDDT3520P		C-frame	
	MHMA High inertia	2000	1000	MHMA102P1	A4-81		MHMA102S1	A4-81			MDDDT3530P	D-frame		
			1500	MHMA152P1	A4-81		MHMA152S1	A4-81			MDDDT5540P			
	3-phase, 200V	MSMD Low inertia	3000	750	MSMD082P1	A4-57	MFCEA 0* * 0EAM	MSMD082S1	A4-57	MFCEA 0* * 0EAE	MFCEA 0* * 0EAD	MCDDT3520P	C-frame	
				1000	MSMA102P1	A4-63		MSMA102S1	A4-63			MDDDT5540P	D-frame	
MSMA Low inertia		3000	1500	MSMA152P1	A4-63		MSMA152S1	A4-63			MDDDT5540P	D-frame		
			2000	MSMA202P1	A4-63		MSMA202S1	A4-63			MEDDT7364P			
			3000	MSMA302P1	A4-65		MSMA302S1	A4-65			MFDDTA390P	F-frame		
			4000	MSMA402P1	A4-65		MSMA402S1	A4-65			MFDDTB3A2P			
MDMA Middle inertia		2000	1000	MDMA102P1	A4-67		MDMA102S1	A4-67			MDDDT3530P	D-frame		
			1500	MDMA152P1	A4-67		MDMA152S1	A4-67			MDDDT5540P			
			2000	MDMA202P1	A4-69		MDMA202S1	A4-69			MEDDT7364P	E-frame		
			3000	MDMA302P1	A4-69		MDMA302S1	A4-69			MFDDTA390P			
			4000	MDMA402P1	A4-71		MDMA402S1	A4-71			MFDDTB3A2P	F-frame		
MGMA Middle inertia		1000	900	MGMA092P1	A4-73	MFCEA 0* * 0ESD	MGMA092S1	A4-73	MFCEA 0* * 0ESE	MFCEA 0* * 0ESD	MDDDT5540P	D-frame		
			2000	MGMA202P1	A4-73		MGMA202S1	A4-73			MFDDTA390P			
			3000	MGMA302P1	A4-75		MGMA302S1	A4-75			MFDDTB3A2P	F-frame		
			4500	MGMA452P1	A4-75		MGMA452S1	A4-75			MDDDT5540P			
MFMA Middle inertia		2000	400	MFMA042P1	A4-77		MFMA042S1	A4-77			MCDDT3520P	C-frame		
			1500	MFMA152P1	A4-77		MFMA152S1	A4-77			MDDDT5540P			
			2500	MFMA252P1	A4-79		MFMA252S1	A4-79			MEDDT7364P	E-frame		
			4500	MFMA452P1	A4-79		MFMA452S1	A4-79			MFDDTB3A2P			
MHMA High inertia		2000	500	MHMA052P1	A4-81		MHMA052S1	A4-81			MCDDT3520P	C-frame		
	1000		MHMA102P1	A4-81		MHMA102S1	A4-81			MDDDT3530P				
	1500		MHMA152P1	A4-81		MHMA152S1	A4-81			MDDDT5540P	D-frame			
	2000		MHMA202P1	A4-83		MHMA202S1	A4-83			MEDDT7364P				
	3000		MHMA302P1	A4-83		MHMA302S1	A4-83			MFDDTA390P	F-frame			
	4000		MHMA402P1	A4-83		MHMA402S1	A4-83			MFDDTB3A2P				
	5000		MHMA502P1	A4-83		MHMA502S1	A4-83			MDDDT5540P				

Optional parts						
	Motor cable Note) 2	Motor cable (with brake) Note) 2	Brake cable Note) 2	Regenerative resistor	Reactor	Noise filter
				DV0P4283	DV0P220	DV0P4170
						DV0P4180
				DV0P4284	DV0P221	DV0P4220
				DV0P4283	DV0P220	DV0P4180
				DV0P4284	DV0P221	DV0P4220
				DV0P4280	DV0P227	DV0P4170
				DV0P4283		
				DV0P4282	DV0P228	DV0P4180
				DV0P4280	DV0P227	DV0P4170
				DV0P4283		
				DV0P4282	DV0P228	DV0P4180
	MFMCB 0* *0EED	—	MFMCB 0* *0GET	DV0P4281	DV0P220	DV0P4170
				DV0P4283	DV0P221	DV0P4180
				DV0P4281	DV0P220	DV0P4170
				DV0P4283	DV0P221	
	MFMCB 0* *2EED			DV0P4284	DV0P222	DV0P4220
		MFMCB 0* *2FCD	—			
	MFMCB 0* *2EED			DV0P4283	DV0P220	DV0P4180
				DV0P4284	DV0P222	DV0P4220
				DV0P4283	DV0P220	DV0P4180
				DV0P4284	DV0P222	DV0P4220
	MFMCB 0* *0EED	—	MFMCB 0* *0GET	DV0P4283	DV0P221	DV0P4180
	MFMCB 0* *2EED	MFMCB 0* *2FCD		DV0P4284	DV0P222	DV0P4220
	MFMCB0* *2ECT	MFMCB0* *2FCT		DV0P4285	DV0P223	
	MFMCB 0* *3ECT	MFMCB 0* *3FCT		DV0P4285	DV0P224	
				X2 in parallel	DV0P225	DV0P3410
					—	
	MFMCB 0* *2EED	MFMCB 0* *2FCD		DV0P4284	DV0P222	DV0P4220
	MFMCB0* *2ECT	MFMCB0* *2FCT		DV0P4285	DV0P223	
	MFMCB 0* *3ECT	MFMCB 0* *3FCT		DV0P4285	DV0P224	
				X2 in parallel	DV0P225	DV0P3410
					—	
	MFMCB0* *2EED	MFMCB0* *2FCD	—	DV0P4284	DV0P222	DV0P4220
	MFMCB 0* *3ECT	MFMCB 0* *3FCT		DV0P4285	DV0P223	
				X2 in parallel	DV0P224	DV0P3410
					—	
	MFMCB 0* *2EED	MFMCB 0* *2FCD		DV0P4283	DV0P220	DV0P4180
				DV0P4284	DV0P222	
	MFMCB 0* *3ECT	MFMCB 0* *3FCT		DV0P4285	DV0P224	DV0P4220
				DV0P4285 X2 in parallel	—	DV0P3410
	MFMCB 0* *2EED	MFMCB 0* *2FCD		DV0P4283	DV0P220	DV0P4180
				DV0P4284	DV0P222	
				DV0P4285	DV0P223	
	MFMCB 0* *3ECT	MFMCB 0* *3FCT		DV0P4285	DV0P224	
				X2 in parallel	DV0P225	DV0P3410
					—	

Carrying page

Options		Part No.	Carrying page
Instruction manual	Japanese	DV0P4480	—
	English	DV0P4490	—
Console		DV0P4420	A4-124
Setup support software, PANATERM [®]	Japanese	DV0P4460	A4-123
	English		
RS232 communication cable (for connection with PC)		DV0P1960	A4-119
Interface cable		DV0P4510	A4-119
Connector kit for external equipment		DV0P4500	A4-118
Connector kit for motor and encoder		DV0P4290	A4-120
		DV0P4380	
		DV0P4310	
		DV0P4320	A4-121
		DV0P4330	
	DV0P4340		
Battery for absolute encoder		DV0P2990	A4-126
Mounting bracket	Frame A	DV0P4271	
	Frame B	DV0P4272	A4-123
	Frame C	DV0P4273	
	Frame D	DV0P4274	
Encoder cable	MFECA0* *0EAD		A4-115
	MFECA0* *0EAE		
	MFECA0* *0EAM		
	MFECA0* *0ESD		
Motor cable	MFECA0* *0ESE		
	MFMCB0* *0EED		A4-116
	MFMCB0* *2ECD		
	MFMCB0* *3ECT		
	MFMCB0* *2ECD		
Motor cable (with brake)	MFMCB0* *2ECT		
	MFMCB0* *3ECT		
	MFMCB0* *2FCD		A4-117
	MFMCB0* *2FCT		
Brake cable	MFMCB0* *0GET		A4-117
Regenerative resistor	50Ω, 25W	DV0P4280	
	100Ω, 25W	DV0P4281	
	25Ω, 50W	DV0P4282	A4-125
	50Ω, 50W	DV0P4283	
	30Ω, 100W	DV0P4284	
	20Ω, 130W	DV0P4285	
Reactor		DV0P220 to DV0P228	A4-124
Noise filter		DV0P4170	
		DV0P4180	A4-110
		DV0P4220	
		DV0P3410	
Surge absorber	Single phase 100V, 200V	DV0P4190	A4-110
	3-phase 200V	DV0P1450	
Noise filter for signal wire		DV0P1460	A4-111

Note) 1. □ represents the motor structure.

Note) 2. **represents the cable length (specified value)

For details, refer to cable specifications (A4-113).

Common Specifications of Driver

Basic specifications	Input power supply	100V-line	Main circuit power	Single phase, 100 – 115V	+10% –15%	50/60Hz	
			Control circuit power	Single phase, 100 – 115V	+10% –15%	50/60Hz	
		200V-line	Main circuit power	Type A, B	Single phase, 200 – 240V	+10% –15%	50/60Hz
				Type C, D	Single/3-phase, 200 – 240V	+10% –15%	50/60Hz
				Type E, F	3-phase, 200 – 230V	+10% –15%	50/60Hz
			Control circuit power	Type A to D	Single phase, 200 – 240V	+10% –15%	50/60Hz
				Type E, F	Single phase, 200 – 240V	+10% –15%	50/60Hz
					Single phase, 200 – 230V	+10% –15%	50/60Hz
	Operation conditions	Temperature		Operation temperature: 0 to 55 degrees Storage temperature: –20 to 80 degrees			
		Humidity		Operation/storage humidity 90%RH or less (no condensation)			
		Height above the sea		Height above the sea level: 1000 m or less			
		Vibration		5.88 m/s ² or less, 10 to 60 Hz (Continuous operation at resonance point is not allowed)			
	Control method			IGBT PWM method, sinusoidal drive			
	Control mode			Select Position control or Full-closed control by parameter.			
	Encoder feedback			17 Bit (resolution: 131072) 7-serial absolute encoder 2500 P/r (resolution: 10000) 5-serial incremental encoder			
	External scale feedback			Compatible with ST771 and AT500 made by Mitutoyo Corporation			
	Control signal	Input (14 inputs)		CW over-travel inhibit, CCW over-travel inhibit, Home sensor, Emergency stop, Point specifying x6 Servo-ON, Strobe, Multi- function input x2			
		Output (10 outputs)		Servo alarm, Brake release signal, Present position output x6, Positioning completion / Output during deceleration, Motor operation condition			
	Pulse signal	Input (4 inputs)		Encoder pulse (A/B/Z-phase) or external scale pulse (EXA/EXB-phase)is output by the line driver. For encoder Z-phase pulse, an open collector output is also available.			
	Setup			Setup with PANATERM® or a console is available. (PANATERM® and a console are sold separately)			
Front panel			[1] 7-segment LED 2-digit [2] Analogue monitor pin (velocity monitor and torque monitor)				
Regeneration			Type A-B : No internal regenerative resist (external only) Type C-F : internal regenerative resist (external is also available)				
Dynamic brake			Built in				

Function	Damping Control		A function to reduce vibration by removing the vibration frequency component when the front end of the machine vibrates.		
	External scale division gradual increase setting range		Ratio between the encoder pulse (numerator) and the external scale pulse (denominator) can be set within the setting range : (1 to 10000 x 2 ⁽⁰⁻¹⁷⁾)/(1 to 10000)		
	The number of points		maximum 60 points		
	Operation mode	Homing operation		Eight types of homing operations [home sensor + Z phase (based on the front end), home sensor (based on the front end), home sensor + Z phase (based on the rear end), limit sensor + Z phase, limit sensor, Z phase homing, Bumping homing, and data set]	
		Jog operation		The motor can be moved in a positive direction or negative direction independently. This is useful for teaching or adjustment.	
		Step operation		The most basic operation. Specify a point number set in advance when performing the operation. The four types of modes [incremental operation, absolute operation, rotary axis operation and dwell timer (waiting time)]	
		Block operation	Continuous block operation	Several step operations can be performed continuously. Once an operation starts, the operation continues to a specified point number.	
			Combined block operation	A step operation is performed according to combined several point numbers. This is useful when you want to change the speed during a step operation.	
		Sequential Operation		A point number increments by 1 automatically whenever an operation command is given. A step operation can be performed easily only by turning the STB signal on/off.	
	Teaching (Console (option) is necessary)		You can operate the motor actually using this console, set a target position and execute some test operations.		
	Auto tuning	Real time		Load inertia is determined at real time in the state of actual operation and gain corresponding to the rigidity is set automatically.	
		Normal mode		Load inertia is determined by driving the equipment with operation command within the driver and gain corresponding to the rigidity is set automatically.	
	Instantaneous speed observer		Available only for position control. A function to improve the speed detection accuracy, achieve the quick response and, at the same time, reduce the vibration at the stop by estimating the motor speed using a load model.		
	Unnecessary wiring mask function		The following control input signal can be masked: CW over-travel inhibit, CCW over-travel inhibit, multi function input1 and 2 , point specifying input(P8-IN,P16-IN,P32-IN), Servo-ON		
	Division function of encoder feedback pulse		The number of pulses can be set up arbitrarily. (at the maximum encoder pulse)		
	Protection function	Hardware error		Overload, undervoltage, overspeed, overload, overheat, over current, encoder error, etc.	
Software error		Large positional deviation, Undefined data error , EEPROM error, etc.			
Alarm data trace back function		Traceable up to 14 alarm data including present alarm data.			

Standard Wiring Example of Main Circuit

■ Frame A, B

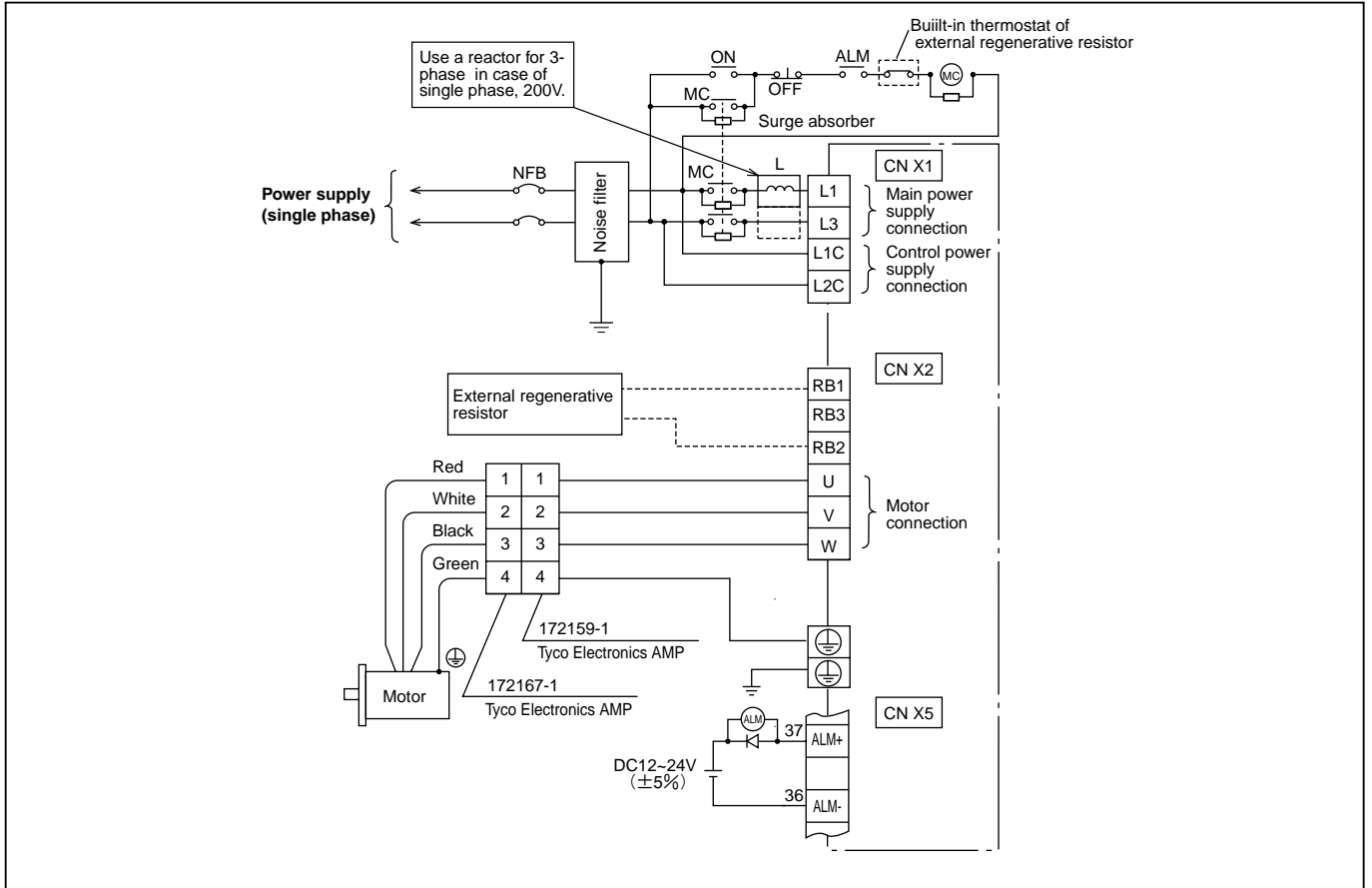

■ Frame C, D

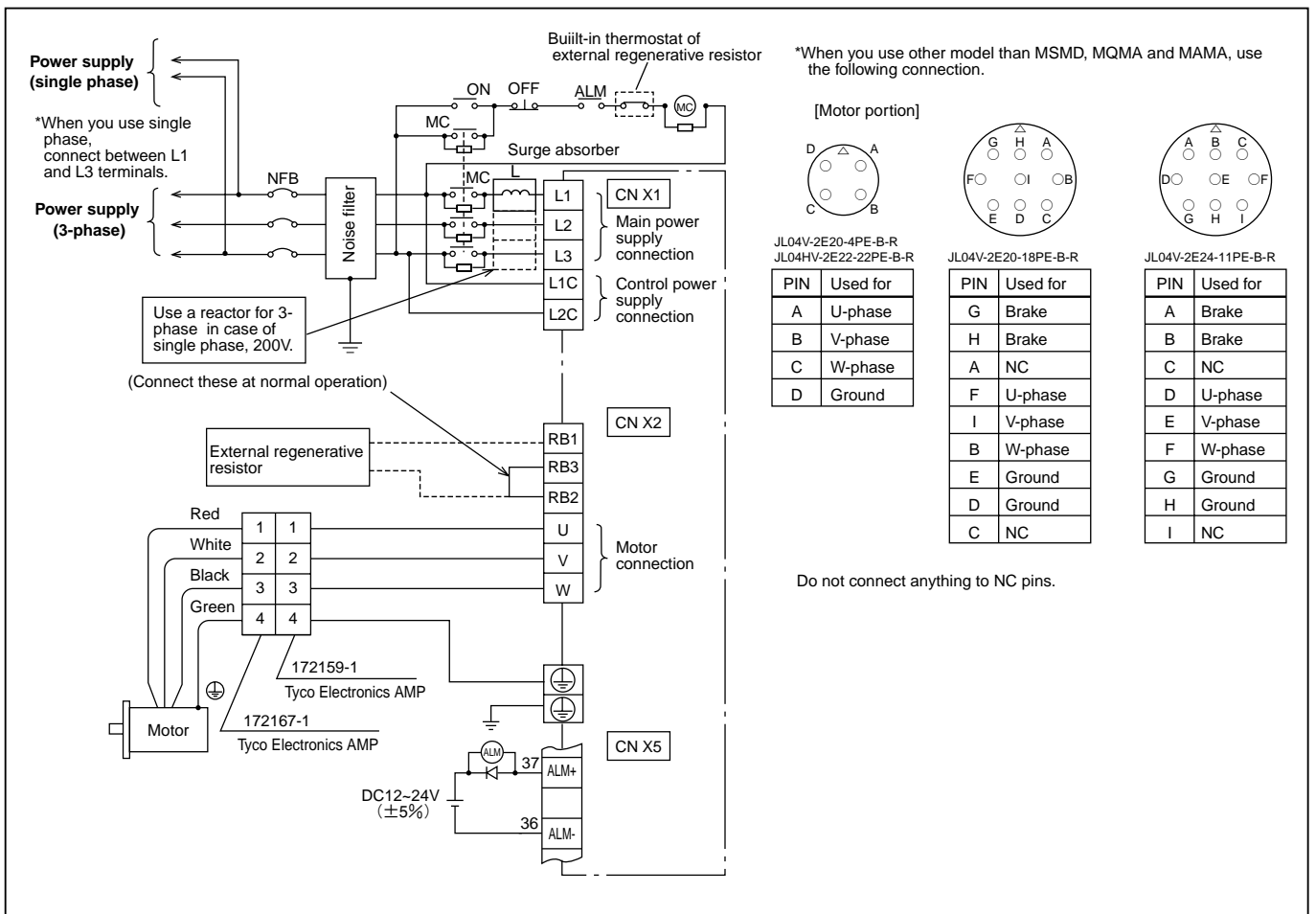

Frame E, F

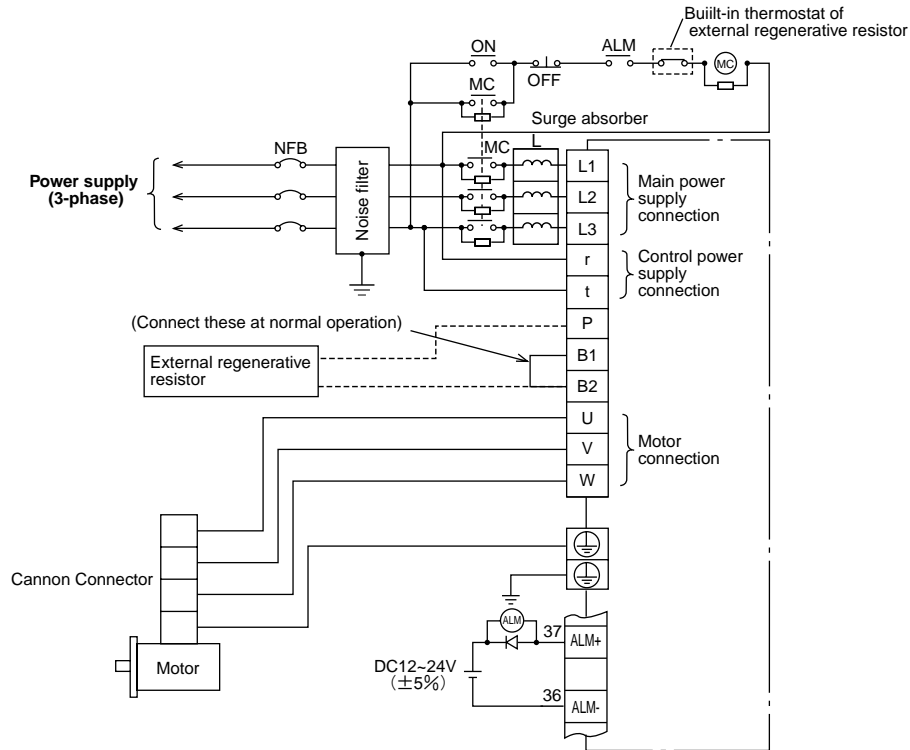

[Motor portion]

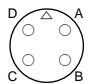

JL04V-2E20-4PE-B-R
JL04HV-2E22-22PE-B-R

PIN	Used for
A	U-phase
B	V-phase
C	W-phase
D	Ground

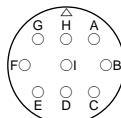

JL04V-2E20-18PE-B-R

PIN	Used for
G	Brake
H	Brake
A	NC
F	U-phase
I	V-phase
B	W-phase
E	Ground
D	Ground
C	NC

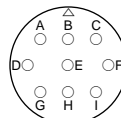

JL04V-2E24-11PE-B-R

PIN	Used for
A	Brake
B	Brake
C	NC
D	U-phase
E	V-phase
F	W-phase
G	Ground
H	Ground
I	NC

Do not connect anything to NC pins.

Encoder Wiring Diagram

■ 2500P/r Incremental encoder

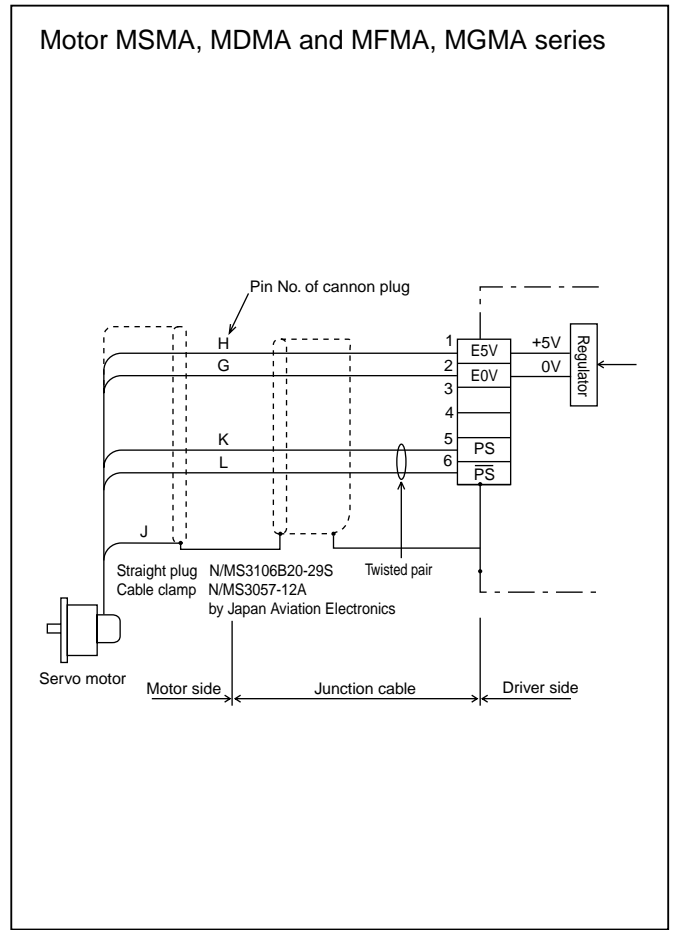
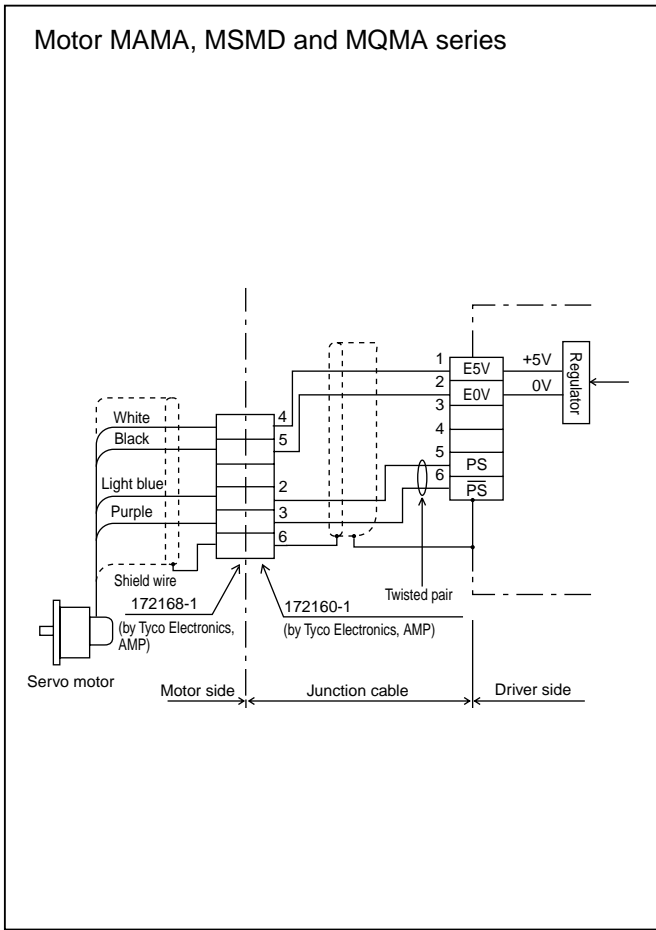

■ 17bit Absolute encoder

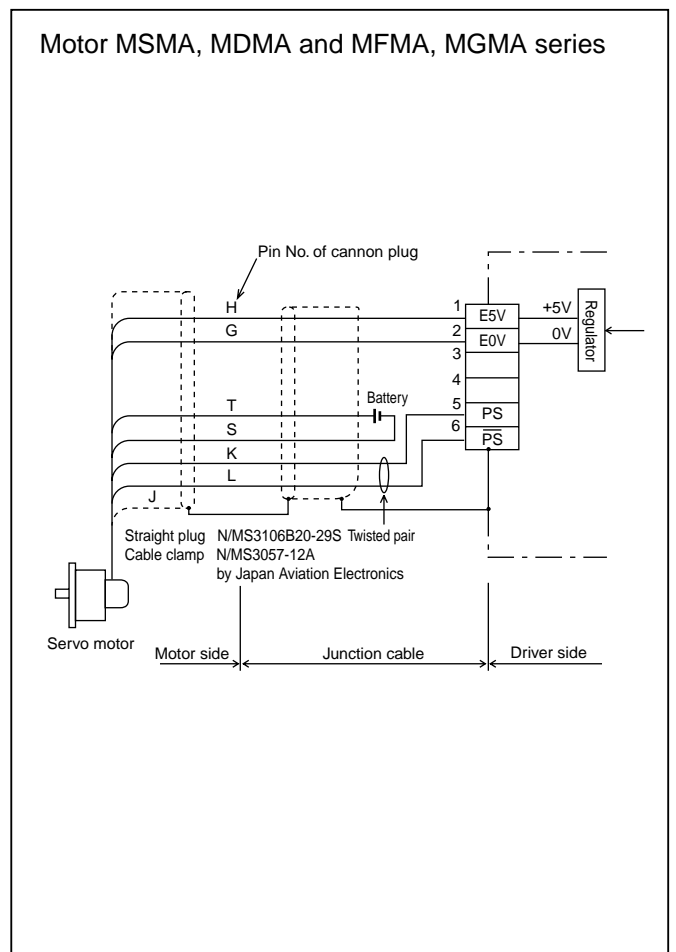
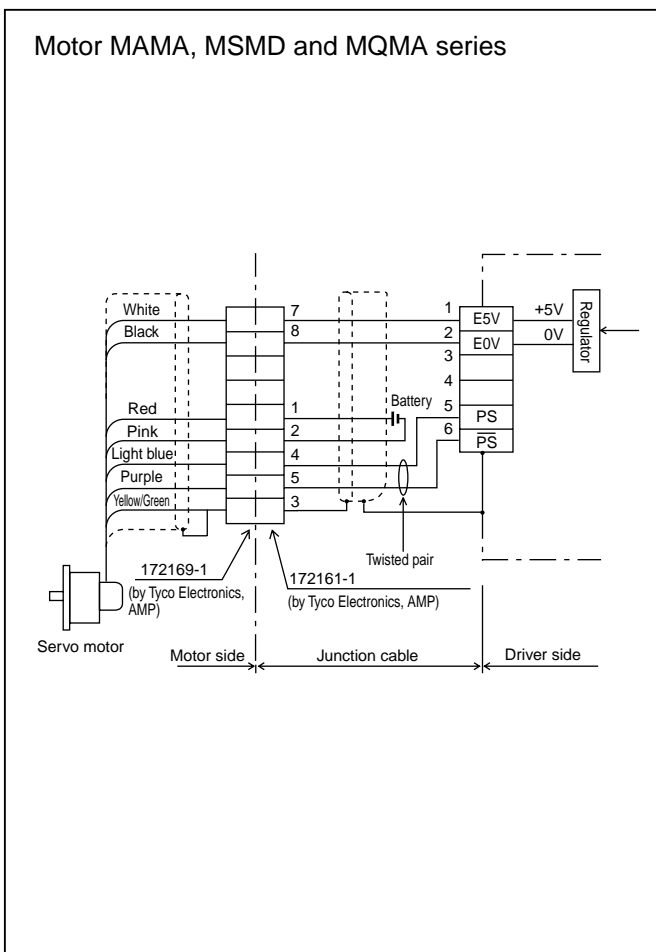

Standard Wiring Example of Control Circuit

■ Wiring example at each control mode

● CN X5 Wiring example at torque control mode

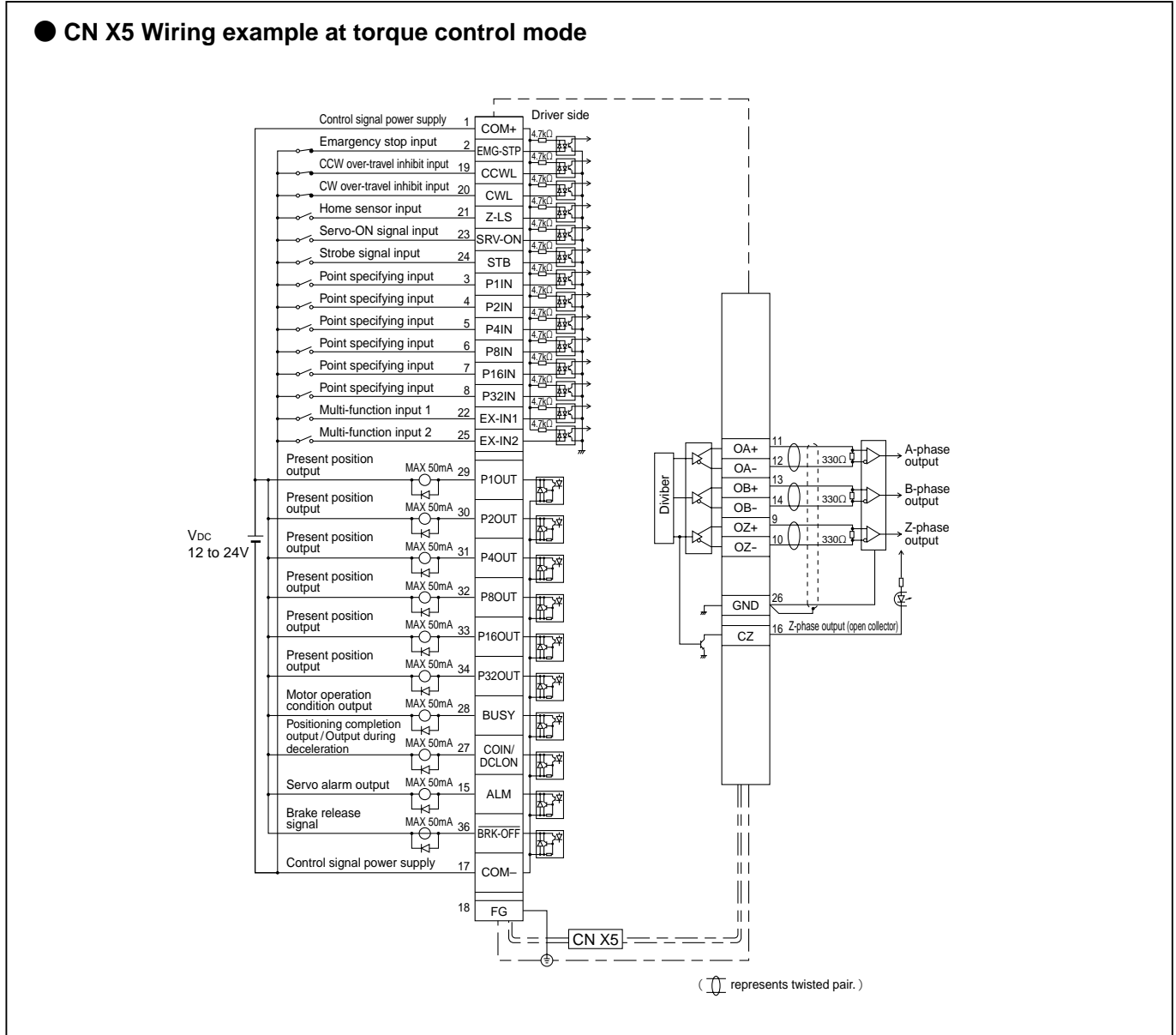

Table of Applicable Motors

Driver		Motor series							
Frame symbol	Part No.	MAMA	MSMD	MQMA	MSMA	MDMA	MGMA	MFMA	MHMA
A-frame	MADDT1105P		MSMD5AZ***						
	MADDT1107P		MSMD011***	MQMA011***					
	MADDT1205P		MSMD5AZ***	MQMA012***					
			MSMD012***						
	MADDT1207P	MAMA012***	MSMD022***	MQMA022***					
B-frame	MBDDT2110P		MSMD021***	MQMA021***					
	MBDDT2210P	MAMA022***	MSMD042***	MQMA042***					
C-frame	MCDDT3120P		MSMD041***	MQMA041***					
	MCDDT3520P	MAMA042***	MSMD082***					MFMA042***	MHMA052***
D-frame	MDDDT3530P					MDMA102***			MHMA102***
	MDDDT5540P	MAMA082***			MSMA102*** MSMA152***	MDMA152***	MGMA092***	MFMA152***	MHMA152***
E-frame	MEDDT7364P				MSMA202***	MDMA202***		MFMA252***	MHMA202***
	MFDDT390P				MSMA302***	MDMA302***	MGMA202***		MHMA302***
F-frame	MFDDT390P				MSMA402***	MDMA402***	MGMA302***	MFMA452***	MHMA402***
	MFDDT3A2P				MSMA502***	MDMA502***	MGMA452***		MHMA502***

Refer to page, A4-37, Table of Part Numbers and Options as well.

Driver/Dimensions

Frame A

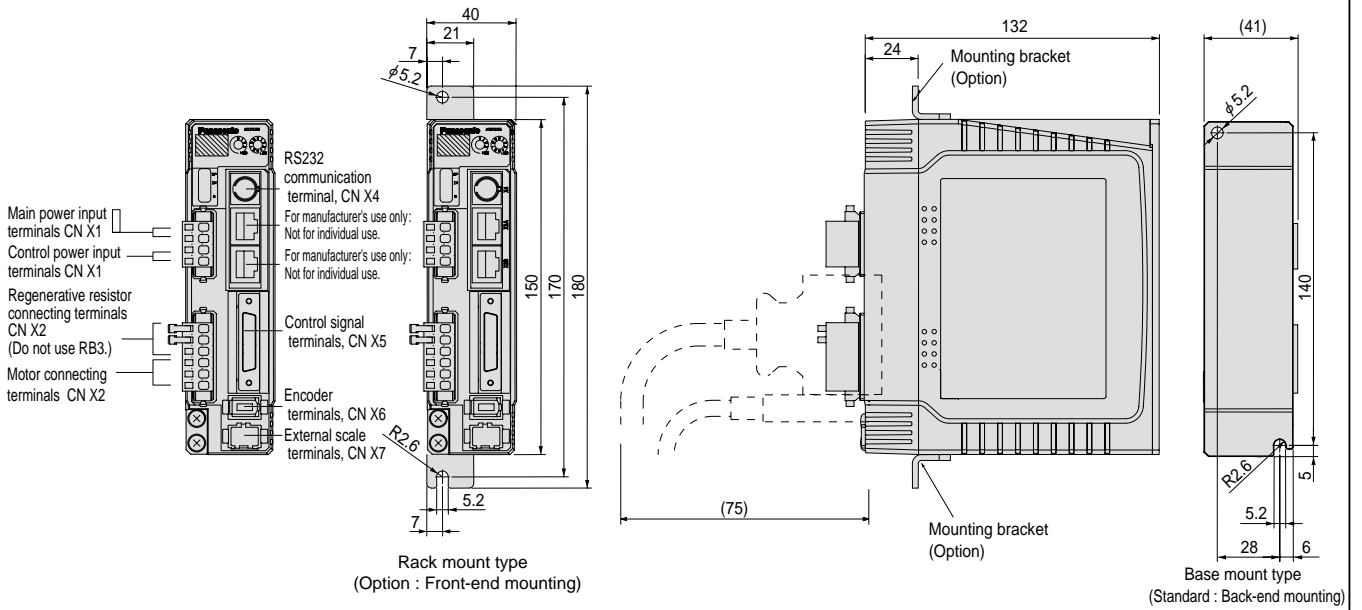

Connector at driver side

Connector sign	Connector type	Manufacturer
CNX7	53460-0629 (or equivalent)	Molex Inc.
CNX6	53460-0629 (or equivalent)	Molex Inc.
CNX5	529865079 (or equivalent)	Molex Inc.
CNX4	MD-S8000-10 (or equivalent)	J.S.T. Mfg.Co., Ltd.
CNX3B	855050013 (or equivalent)	Molex Inc.
CNX3A	855050013 (or equivalent)	Molex Inc.
CNX2	S06B-F32SK-GGXR (or equivalent)	J.S.T. Mfg.Co., Ltd.
CNX1	S04B-F32SK-GGXR (or equivalent)	J.S.T. Mfg.Co., Ltd.

Connector at Power Supply and Motor side

Connector sign	Connector type	Manufacturer
CNX2	06JFAT-SAXGF (or equivalent)	J.S.T. Mfg.Co., Ltd.
CNX1	04JFAT-SAXGF (or equivalent)	J.S.T. Mfg.Co., Ltd.

Mass 0.8kg

Frame B

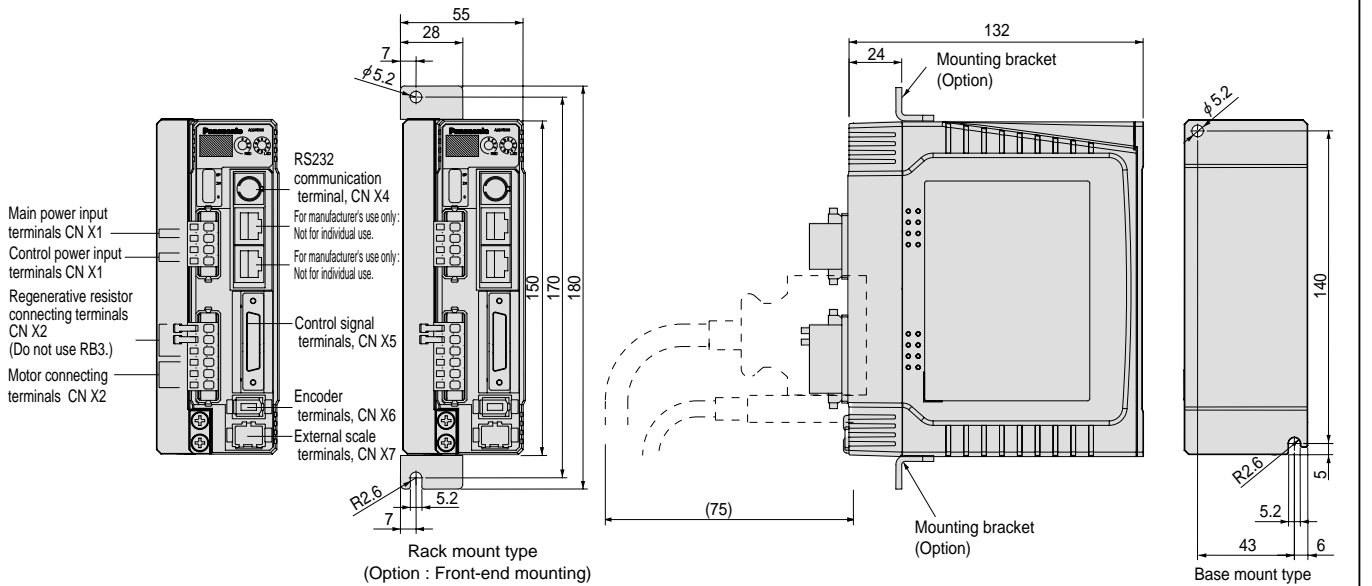

Connector at driver side

Connector sign	Connector type	Manufacturer
CNX7	53460-0629 (or equivalent)	Molex Inc.
CNX6	53460-0629 (or equivalent)	Molex Inc.
CNX5	529865079 (or equivalent)	Molex Inc.
CNX4	MD-S8000-10 (or equivalent)	J.S.T. Mfg.Co., Ltd.
CNX3B	855050013 (or equivalent)	Molex Inc.
CNX3A	855050013 (or equivalent)	Molex Inc.
CNX2	S06B-F32SK-GGXR (or equivalent)	J.S.T. Mfg.Co., Ltd.
CNX1	S04B-F32SK-GGXR (or equivalent)	J.S.T. Mfg.Co., Ltd.

Connector at Power Supply and Motor side

Connector sign	Connector type	Manufacturer
CNX2	06JFAT-SAXGF (or equivalent)	J.S.T. Mfg.Co., Ltd.
CNX1	04JFAT-SAXGF (or equivalent)	J.S.T. Mfg.Co., Ltd.

Mass 1.1kg

Frame C

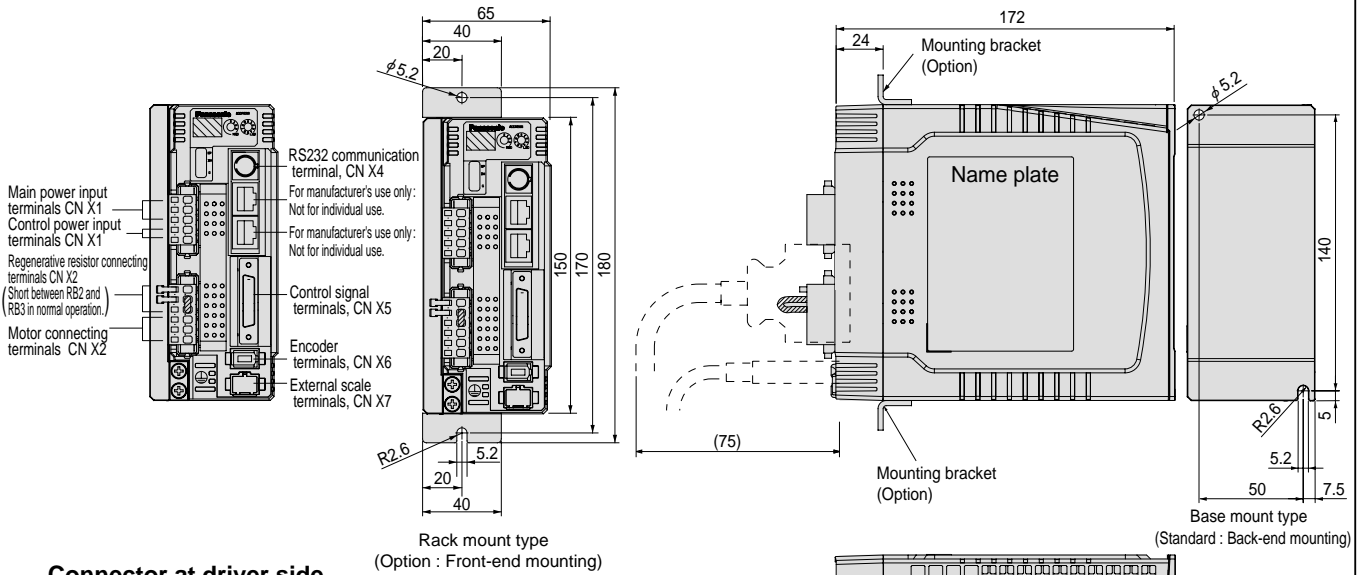

Connector at driver side

Connector sign	Connector type	Manufacturer
CNX7	53460-0629 (or equivalent)	Molex Inc.
CNX6	53460-0629 (or equivalent)	Molex Inc.
CNX5	529865079 (or equivalent)	Molex Inc.
CNX4	MD-S8000-10 (or equivalent)	J.S.T. Mfg.Co., Ltd.
CNX3B	855050013 (or equivalent)	Molex Inc.
CNX3A	855050013 (or equivalent)	Molex Inc.
CNX2	S06B-F32SK-GGXR (or equivalent)	J.S.T. Mfg.Co., Ltd.
CNX1	S05B-F32SK-GGXR (or equivalent)	J.S.T. Mfg.Co., Ltd.

Connector at Power Supply and Motor side

Connector sign	Connector type	Manufacturer
CNX2	06JFAT-SAXGF (or equivalent)	J.S.T. Mfg.Co., Ltd.
CNX1	05JFAT-SAXGF (or equivalent)	J.S.T. Mfg.Co., Ltd.

Mass 1.5kg

Frame D

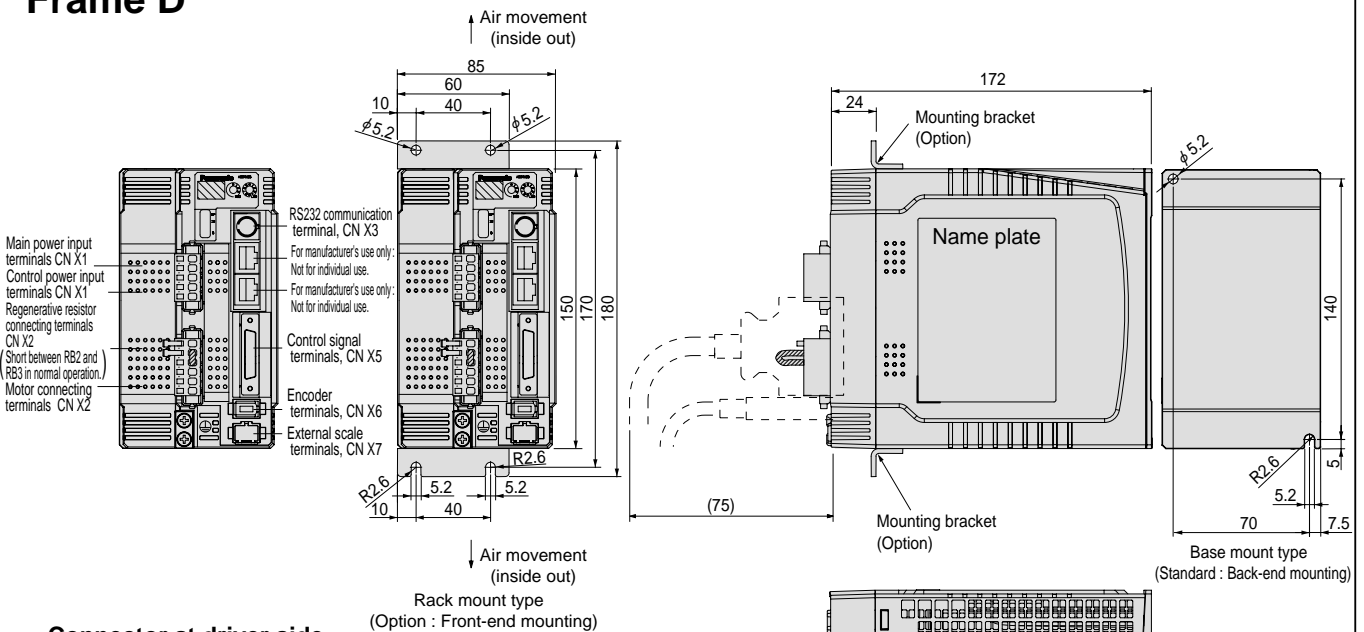

Connector at driver side

Connector sign	Connector type	Manufacturer
CNX7	53460-0629 (or equivalent)	Molex Inc.
CNX6	53460-0629 (or equivalent)	Molex Inc.
CNX5	529865079 (or equivalent)	Molex Inc.
CNX4	MD-S8000-10 (or equivalent)	J.S.T. Mfg.Co., Ltd.
CNX3B	855050013 (or equivalent)	Molex Inc.
CNX3A	855050013 (or equivalent)	Molex Inc.
CNX2	S06B-F32SK-GGXR (or equivalent)	J.S.T. Mfg.Co., Ltd.
CNX1	S05B-F32SK-GGXR (or equivalent)	J.S.T. Mfg.Co., Ltd.

Connector at Power Supply and Motor side

Connector sign	Connector type	Manufacturer
CNX2	06JFAT-SAXGF (or equivalent)	J.S.T. Mfg.Co., Ltd.
CNX1	05JFAT-SAXGF (or equivalent)	J.S.T. Mfg.Co., Ltd.

Mass 1.7kg

Driver/Dimensions

Frame E

Main power input terminals
 Control power input terminals
 Regenerative resistor connecting terminals (short between B1 and B2 in normal operation)
 Motor connecting terminals
 Earth terminals

RS232 communication terminal, CN X4
 For manufacturer's use only: Not for individual use.
 For manufacturer's use only: Not for individual use.
 Control signal terminals, CN X5
 Encoder terminals, CN X6
 External scale terminals, CN X7

Air movement (inside out)

(88)
 85
 50
 17.5
 5.2
 42.5
 5.2
 168
 188
 198
 5.2
 42.5
 5.2
 50
 17.5

(200)
 32.1
 2.6
 Mounting bracket (Standard)
 Mounting bracket (put substitution of the Standard for the back-end)
 Name plate
 (75)

Connector at driver side

Connector sign	Connector type	Manufacturer
CNX7	53460-0629 (or equivalent)	Molex Inc.
CNX6	53460-0629 (or equivalent)	Molex Inc.
CNX5	529865079 (or equivalent)	Molex Inc.
CNX4	MD-S8000-10 (or equivalent)	J.S.T. Mfg.Co., Ltd.
CNX3B	855050013 (or equivalent)	Molex Inc.
CNX3A	855050013 (or equivalent)	Molex Inc.

Air movement (inside out)

Mass 3.2kg

Frame F

Main power input terminals
 Control power input terminals
 Regenerative resistor connecting terminals (short between B1 and B2 in normal operation)
 Motor connecting terminals
 Earth terminals

RS232 communication terminal, CN X4
 For manufacturer's use only: Not for individual use.
 For manufacturer's use only: Not for individual use.
 Control signal terminals, CN X5
 Encoder terminals, CN X6
 External scale terminals, CN X7

Air movement (from front to back)

130
 100
 15
 5.2
 65
 5.2
 220
 240
 250
 5.2
 65
 100
 15

(200)
 32.3
 2.6
 Mounting bracket (Standard)
 Mounting bracket (put substitution of the Standard for the back-end)
 Name plate
 (75)

Connector at driver side

Connector sign	Connector type	Manufacturer
CNX7	53460-0629 (or equivalent)	Molex Inc.
CNX6	53460-0629 (or equivalent)	Molex Inc.
CNX5	529865079 (or equivalent)	Molex Inc.
CNX4	MD-S8000-10 (or equivalent)	J.S.T. Mfg.Co., Ltd.
CNX3B	855050013 (or equivalent)	Molex Inc.
CNX3A	855050013 (or equivalent)	Molex Inc.

Mass 6.0kg

MINAS A4 A4P Series

Motor/Option Contents

- Motor
 - <Ratings/Specifications/Torque Characteristics> ----- A4-49
 - MAMA ----- A4-49
 - MSMD ----- A4-51
 - MQMA ----- A4-59
 - MSMA ----- A4-63
 - MDMA ----- A4-67
 - MGMA ----- A4-73
 - MFMA ----- A4-78
 - MHMA ----- A4-81
 - <Dimensions> ----- A4-87
 - MAMA ----- A4-87
 - MSMD ----- A4-88
 - MQMA ----- A4-90
 - MSMA ----- A4-91
 - MDMA ----- A4-93
 - MGMA ----- A4-96
 - MFMA ----- A4-99
 - MHMA ----- A4-101
- Motor with Gear Reducer/MSMD
 - <General Specifications> ----- A4-105
 - <Ratings/Specifications> ----- A4-106
 - <Torque Characteristics> ----- A4-107
 - <Dimensions> ----- A4-108
- Conformity to CE and UL ----- A4-109
- IP65 Rating ----- A4-112
- Options ----- A4-113
- Recommended components ----- A4-127

Motor Specifications and Ratings **200V** MAMA 100W to 750W Ultra low inertia Small capacity

		AC200V									
Motor model		MAMA		012P1□	012S1□	022P1□	022S1□	042P1□	042S1□	082P1□	082S1□
Applicable driver	Model No.	A4 series	MADDT1207		MBDDT2210		MCDDT3520		MDDDT5540		
		A4P series	MADDT1207P		MBDDT2210P		MCDDT3520P		MDDDT5540P		
	Frame symbol	Frame A		Frame B		Frame C		Frame D			
Power supply capacity (kVA)		0.4		0.5		1.0		1.3			
Rated output (W)		100		200		400		750			
Rated torque (N · m)		0.19		0.38		0.76		1.43			
Momentary Max. peak torque (N · m)		0.95		1.91		3.82		7.16			
Rated current (Arms)		0.9		1.54		3.1		5.1			
Max. current (Ao-p)		6.3		10.9		21.7		36.0			
Regenerative brake frequency (times/min) Note)1	Without option	No limit Note)2									
	DV0P4283	No limit Note)2									
	DV0P4284	No limit Note)2									
Rated rotational speed (r/min)		5000									
Max. rotational speed (r/min)		6000									
Moment of inertia of rotor (x10 ⁻⁴ kg · m ²)	Without brake	0.025	0.035	0.078	0.088	0.14	0.15	0.50	0.51		
	With brake	0.029	0.039	0.11	0.12	0.17	0.18	0.58	0.59		
Recommended moment of inertia ratio of the load and the rotor Note)3		Smaller than 15 times									
Rotary encoder specifications		2500P/r Incremental	17-bit Absolute/ Incremental	2500P/r Incremental	17-bit Absolute/ Incremental	2500P/r Incremental	17-bit Absolute/ Incremental	2500P/r Incremental	17-bit Absolute/ Incremental		
		Resolution per single turn	10000	131072	10000	131072	10000	131072	10000	131072	
Protective enclosure rating		IP65 (except shaft through hole and cable end connector)									
Environment	Ambient temperature	0 to 40°C (free from freezing), Storage : -20 to + 80°C									
	Ambient humidity	85%RH or lower (free from condensing)									
	Installation location	Indoors (no direct sunlight), free from corrosive gas, inflammable gas, oil mist and dust									
	Altitude	1000m or lower									
	Vibration resistance	49m/s ² or less	24m/s ² or less	49m/s ² or less	24m/s ² or less	49m/s ² or less	24m/s ² or less	49m/s ² or less	24m/s ² or less		
Mass (kg), () represents holding brake type		0.65 (0.85)	0.71 (0.91)	1.1 (1.5)	1.2 (1.6)	1.5 (1.9)	1.6 (2.0)	3.3 (4.0)	3.4 (4.1)		

Brake specifications (This brake will be released when it is energized. Do not use this for braking the motor in motion.)			
Static friction torque (N·m)	0.29		2.45
Engaging time (ms)	35		70
Releasing time (ms) Note)4	10 (60)		20 (—)
Exciting current (DC) (A)	0.25		0.35
Releasing voltage	DC2V or more		
Exciting voltage	DC 24 V ± 5%		

Permissible load			
During assembly	Radial load P-direction (N)	147	686
	Thrust load A-direction (N)	88	294
	Thrust load B-direction (N)	117.6	392
During operation	Radial load P-direction (N)	68.6	392
	Thrust load A-direction (N)	49	68.6
	Thrust load B-direction (N)	49	68.6

For motor dimensions, refer to page A4-87 , and for the diver, refer to pages A4-22,23 and A4-45,46.

Model designation MAMA series, 100W to 750W

e.g.)

M A M A 0 1 2 S 1 A

Symbol	Type
MAMA	Ultra low inertia (100W-750W)

Voltage specifications	
Symbol	Specifications
2	200V

Design order
1 : Standard

Motor structure

Symbol	Shaft		Holding brake		Oil seal	
	Round	Key-way	without	with	without	with
A	●		●		●	
B	●			●	●	
E		●	●		●	
F		●		●	●	

Motor rated output

Symbol	Rated output
01	100W
02	200W
04	400W
08	750W

Rotary encoder specifications

Symbol	Format	Pulse counts	Resolution	Wires
P	Incremental	2500P/r	10000	5
S	Absolute/Incremental	17-bit	131072	7

Torque characteristics at AC200V of power voltage

MAMA012□1□

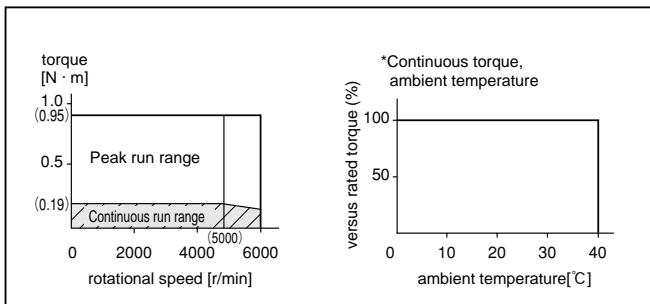

MAMA022□1□

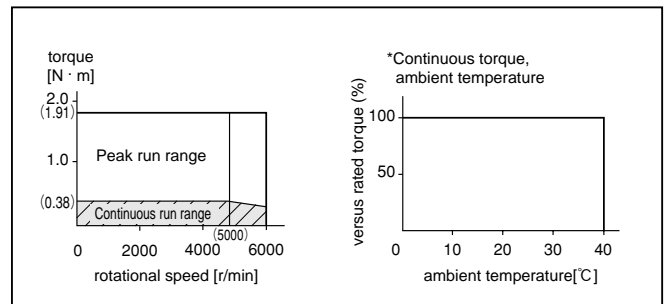

MAMA042□1□

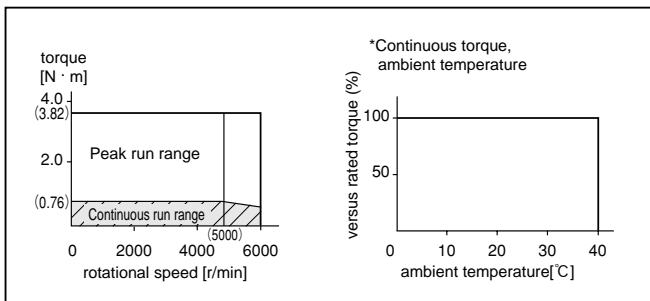

MAMA082□1□

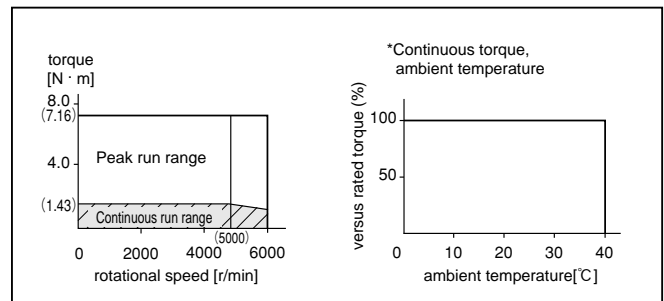

*When you lower the torque limit setup (Pr5E and 5F), running range at high speed might be lowered as well.

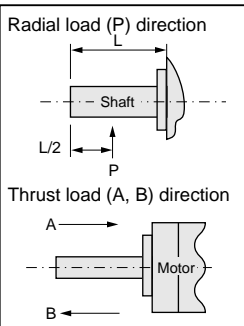
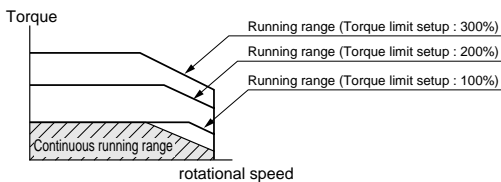

- Note) 1. Regenerative brake frequency represents the frequency of the motor's stops from the rated speed with deceleration without load.
- If the load is connected, frequency will be defined as $1/(m+1)$, where m =load moment of inertia/rotor moment of inertia.
 - When the motor speed exceeds the rated speed, regenerative brake frequency is in inverse proportion to the square of (running speed/rated speed).
 - Power supply voltage is AC230V (at 200V of the main voltage).
 - If the supply voltage fluctuates, frequency is in inverse proportion to the square of (Running supply voltage/230) relative to the value in the table.
 - When regeneration occurs continuously such cases as running speed frequently changes or vertical feeding, consult us or a dealer.
2. If the effective torque is within the rated torque, there is no limit in regenerative brake.
3. Consult us or a dealer if the load moment of inertia exceeds the specified value.
4. Specified releasing time is obtained with the use of surge absorber for brake (Z15D151 by Ishizuka Electronic or equivalent).
() represents the actually measured value using a diode (200V, 1A or equivalent)

Motor Specifications and Ratings 100V MSMD 50W to 100W Low inertia Small Capacity

		AC100V					
Motor model		MSMD		5AZP1□	5AZS1□	011P1□	011S1□
Applicable driver	Model No.	A4 series	MADDT1105		MADDT1107		
		A4P series	MADDT1105P		MADDT1107P		
	Frame symbol		Frame A				
Power supply capacity (kVA)		0.3			0.4		
Rated output (W)		50			100		
Rated torque (N · m)		0.16			0.32		
Momentary Max. peak torque (N · m)		0.48			0.95		
Rated current (Arms)		1.1			1.7		
Max. current (Ao-p)		4.7			7.2		
Regenerative brake frequency (times/min) Note)1	Without option	No limit Note)2					
	DV0P4280	No limit Note)2					
Rated rotational speed (r/min)		3000					
Max. rotational speed (r/min)		5000					
Moment of inertia of rotor ($\times 10^{-4}$ kg · m ²)	Without brake	0.025			0.051		
	With brake	0.027			0.054		
Recommended moment of inertia ratio of the load and the rotor Note)3		Smaller than 30 times					
Rotary encoder specifications		2500P/r Incremental		17-bit Absolute/ Incremental		2500P/r Incremental	
		Resolution per single turn		131072		131072	
Protective enclosure rating		IP65 (except shaft through hole and cable end connector)					
Environment	Ambient temperature	0 to 40°C (free from freezing), Storage : -20 to + 80°C					
	Ambient humidity	85%RH or lower (free from condensing)					
	Installation location	Indoors (no direct sunlight), free from corrosive gas, inflammable gas, oil mist and dust					
	Altitude	1000m or lower					
	Vibration resistance	49m/s ² or less			49m/s ² or less		
Mass (kg), () represents holding brake type		0.32 (0.53)			0.47 (0.68)		

Brake specifications (This brake will be released when it is energized. Do not use this for braking the motor in motion.)	
Static friction torque (N·m)	0.29
Engaging time (ms)	35
Releasing time (ms) Note)4	20 (—)
Exciting current (DC) (A)	0.30
Releasing voltage	DC1V or more
Exciting voltage	DC 24 V \pm 5%

Permissible load		
During assembly	Radial load P-direction (N)	147
	Thrust load A-direction (N)	88
	Thrust load B-direction (N)	117
During operation	Radial load P-direction (N)	68
	Thrust load A-direction (N)	58
	Thrust load B-direction (N)	58

For motor dimensions, refer to page A4-88 , and for the diver, refer to pages A4-22 and 45.

Model designation MSMD series, 50W to 100W

e.g.)

M S M D 5 A Z S 1 S

Symbol	Type
MSMD	Low inertia (50W-100W)

Voltage specifications

Symbol	Specifications
1	100V
Z	100/200V (50W only)

Design order
1 : Standard

Motor structure

Symbol	Shaft		Holding brake		Oil seal	
	Round	Key-way, center tap	without	with	without	with*
A	●		●		●	
B	●			●	●	
S		●	●		●	
T		●		●	●	

*Motor with oil seal is manufactured by order.

Motor rated output

Symbol	Rated output
5A	50W
01	100W

Rotary encoder specifications

Symbol	Format	Pulse counts	Resolution	Wires
P	Incremental	2500P/r	10000	5
S	Absolute/Incremental	17-bit	131072	7

Torque characteristics at AC100V of power voltage

(Dotted line represents the torque at 10% less supply voltage.)

MSMD5AZ□1□

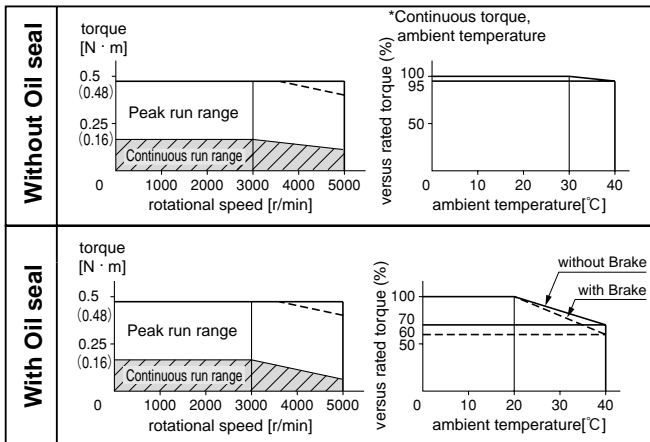

MSMD011 □1□

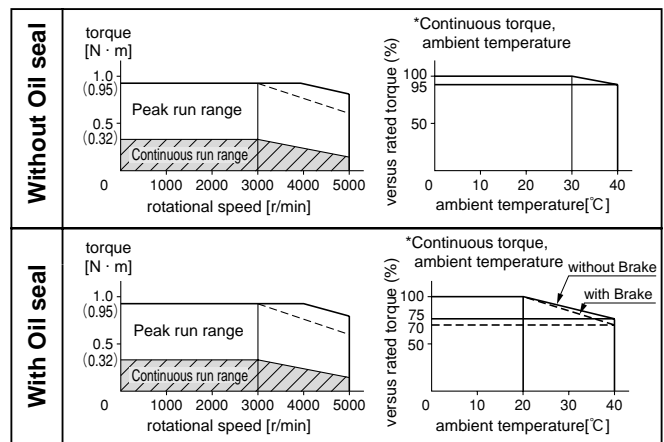

*When you lower the torque limit setup (Pr5E and 5F), running range at high speed might be lowered as well.

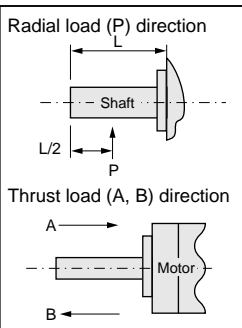
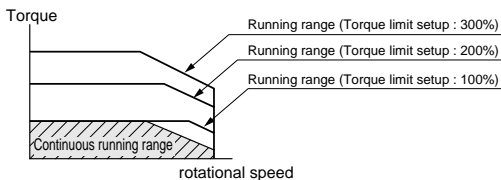

Note) 1. Regenerative brake frequency represents the frequency of the motor's stops from the rated speed with deceleration without load.

- If the load is connected, frequency will be defined as $1/(m+1)$, where m =load moment of inertia/rotor moment of inertia.
 - When the motor speed exceeds the rated speed, regenerative brake frequency is in inverse proportion to the square of (running speed/rated speed).
 - Power supply voltage is AC115V (at 100V of the main voltage).
If the supply voltage fluctuates, frequency is in inverse proportion to the square of (Running supply voltage/115) relative to the value in the table.
 - When regeneration occurs continuously such cases as running speed frequently changes or vertical feeding, consult us or a dealer.
2. If the effective torque is within the rated torque, there is no limit in regenerative brake.
 3. Consult us or a dealer if the load moment of inertia exceeds the specified value.
 4. Specified releasing time is obtained with the use of surge absorber for brake (Z15D271 by Ishizuka Electronic or equivalent).
() represents the actually measured value using a diode (200V, 1A or equivalent)

Motor Specifications and Ratings 100V MSMD

200W to 400W Low inertia Small Capacity

		AC100V					
Motor model		MSMD		021P1 <input type="checkbox"/>	021S1 <input type="checkbox"/>	041P1 <input type="checkbox"/>	041S1 <input type="checkbox"/>
Applicable driver	Model No.	A4 series		MBDDT2110		MCDDT3120	
		A4P series		MBDDT2110P		MCDDT3120P	
	Frame symbol	Frame B		Frame C			
Power supply capacity (kVA)		0.5		1.0			
Rated output (W)		200		400			
Rated torque (N · m)		0.64		1.3			
Momentary Max. peak torque (N · m)		1.91		3.8			
Rated current (Arms)		2.5		4.6			
Max. current (Ao-p)		10.6		19.5			
Regenerative brake frequency (times/min) Note)1	Without option	No limit Note)2		No limit Note)2			
	DV0P4282	—		No limit Note)2			
	DV0P4283	No limit Note)2		—			
Rated rotational speed (r/min)		3000		5000			
Max. rotational speed (r/min)		3000		5000			
Moment of inertia of rotor ($\times 10^{-4}$ kg · m ²)	Without brake	0.14		0.26			
	With brake	0.16		0.28			
Recommended moment of inertia ratio of the load and the rotor Note)3		Smaller than 30 times		Smaller than 30 times			
Rotary encoder specifications		2500P/r Incremental	17-bit Absolute/ Incremental	2500P/r Incremental	17-bit Absolute/ Incremental		
	Resolution per single turn	10000	131072	10000	131072		
Protective enclosure rating		IP65 (except shaft through hole and cable end connector)		IP65 (except shaft through hole and cable end connector)			
Environment	Ambient temperature	0 to 40°C (free from freezing), Storage : -20 to + 80°C		0 to 40°C (free from freezing), Storage : -20 to + 80°C			
	Ambient humidity	85%RH or lower (free from condensing)		85%RH or lower (free from condensing)			
	Installation location	Indoors (no direct sunlight), free from corrosive gas, inflammable gas, oil mist and dust		Indoors (no direct sunlight), free from corrosive gas, inflammable gas, oil mist and dust			
	Altitude	1000m or lower		1000m or lower			
	Vibration resistance	49m/s ² or less		49m/s ² or less			
Mass (kg), () represents holding brake type		0.82 (1.3)		1.2 (1.7)			

Brake specifications (This brake will be released when it is energized. Do not use this for braking the motor in motion.)	
Static friction torque (N·m)	1.27
Engaging time (ms)	50
Releasing time (ms) Note)4	15 (—)
Exciting current (DC) (A)	0.36
Releasing voltage	DC1V or more
Exciting voltage	DC 24 V \pm 5%

Permissible load		
During assembly	Radial load P-direction (N)	392
	Thrust load A-direction (N)	147
	Thrust load B-direction (N)	196
During operation	Radial load P-direction (N)	245
	Thrust load A-direction (N)	98
	Thrust load B-direction (N)	98

For motor dimensions, refer to page A4-89 , and for the diver, refer to pages A4-22,23 and A4-45,46.

Model designation MSMD series, 200W to 400W

e.g.) **M S M D 0 2 1 S 1 S**

Symbol	Type
MSMD	Low inertia (200W-400W)

Voltage specifications	
Symbol	Specifications
1	100V

Design order
1 : Standard

Motor structure

Symbol	Shaft		Holding brake		Oil seal	
	Round	Key-way, center tap	without	with	without	with*
A	●		●		●	
B	●			●	●	
S		●	●		●	
T		●		●	●	

* Motor with oil seal is manufactured by order.

Motor rated output

Symbol	Rated output
02	200W
04	400W

Rotary encoder specifications

Symbol	Format	Pulse counts	Resolution	Wires
P	Incremental	2500P/r	10000	5
S	Absolute/Incremental	17-bit	131072	7

Torque characteristics at AC100V of power voltage

(Dotted line represents the torque at 10% less supply voltage.)

MSMD021□1□

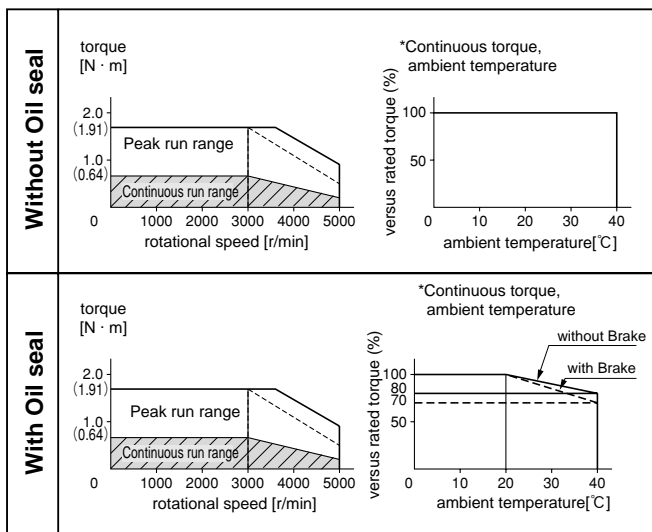

MSMD041□1□

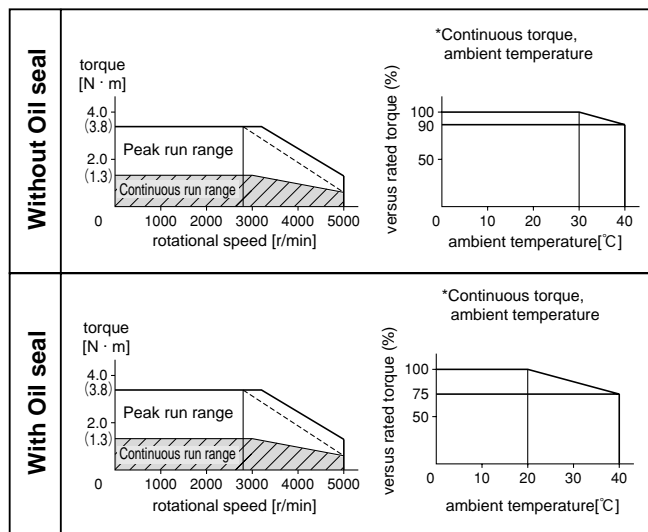

*When you lower the torque limit setup (Pr5E and 5F), running range at high speed might be lowered as well.

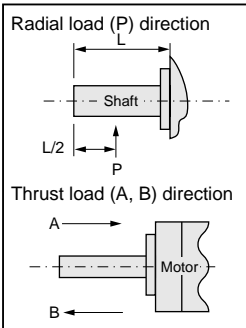
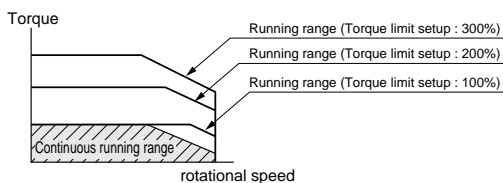

- Note 1. Regenerative brake frequency represents the frequency of the motor's stops from the rated speed with deceleration without load.
- If the load is connected, frequency will be defined as $1/(m+1)$, where m =load moment of inertia/rotor moment of inertia.
 - When the motor speed exceeds the rated speed, regenerative brake frequency is in inverse proportion to the square of (running speed/rated speed).
 - Power supply voltage is AC115V (at 100V of the main voltage).
 - If the supply voltage fluctuates, frequency is in inverse proportion to the square of (Running supply voltage/115) relative to the value in the table.
 - When regeneration occurs continuously such cases as running speed frequently changes or vertical feeding, consult us or a dealer.
2. If the effective torque is within the rated torque, there is no limit in generative brake.
 3. Consult us or a dealer if the load moment of inertia exceeds the specified value.
 4. Specified releasing time is obtained with the use of surge absorber for brake (Z15D271 by Ishizuka Electronic or equivalent). () represents the actually measured value using a diode (200V, 1A or equivalent)

Motor Specifications and Ratings 200V MSMD

50W to 100W Low inertia Small Capacity

		AC200V					
Motor model		MSMD		5AZP1 <input type="checkbox"/>	5AZS1 <input type="checkbox"/>	012P1 <input type="checkbox"/>	012S1 <input type="checkbox"/>
Applicable driver	Model No.	A4 series	MADDT1205				
		A4P series	MADDT1205P				
	Frame symbol		Frame A				
Power supply capacity (kVA)		0.3			0.3		
Rated output (W)		50			100		
Rated torque (N · m)		0.16			0.32		
Momentary Max. peak torque (N · m)		0.48			0.95		
Rated current (Arms)		1.1					
Max. current (Ao-p)		4.7					
Regenerative brake frequency (times/min) Note)1	Without option	No limit Note)2					
	DV0P4281	No limit Note)2					
Rated rotational speed (r/min)		3000					
Max. rotational speed (r/min)		5000					
Moment of inertia of rotor ($\times 10^{-4}$ kg · m ²)	Without brake	0.025			0.051		
	With brake	0.027			0.054		
Recommended moment of inertia ratio of the load and the rotor Note)3		Smaller than 30 times					
Rotary encoder specifications		2500P/r Incremental		17-bit Absolute/ Incremental		2500P/r Incremental	
		Resolution per single turn		131072		131072	
Protective enclosure rating		IP65 (except shaft through hole and cable end connector)					
Environment	Ambient temperature	0 to 40°C (free from freezing), Storage : -20 to + 80°C					
	Ambient humidity	85%RH or lower (free from condensing)					
	Installation location	Indoors (no direct sunlight), free from corrosive gas, inflammable gas, oil mist and dust					
	Altitude	1000m or lower					
	Vibration resistance	49m/s ² or less			49m/s ² or less		
Mass (kg), () represents holding brake type		0.32 (0.53)			0.47 (0.68)		

Brake specifications (This brake will be released when it is energized. Do not use this for braking the motor in motion.)	
Static friction torque (N·m)	0.29
Engaging time (ms)	35
Releasing time (ms) Note)4	20 (—)
Exciting current (DC) (A)	0.30
Releasing voltage	DC1V or more
Exciting voltage	DC 24 V \pm 5%

Permissible load		
During assembly	Radial load P-direction (N)	147
	Thrust load A-direction (N)	88
	Thrust load B-direction (N)	117
During operation	Radial load P-direction (N)	68
	Thrust load A-direction (N)	58
	Thrust load B-direction (N)	58

For motor dimensions, refer to page A4-88 , and for the diver, refer to pages A4-22 and 45.

Model designation MSMD series, 50W to 100W

e.g.)

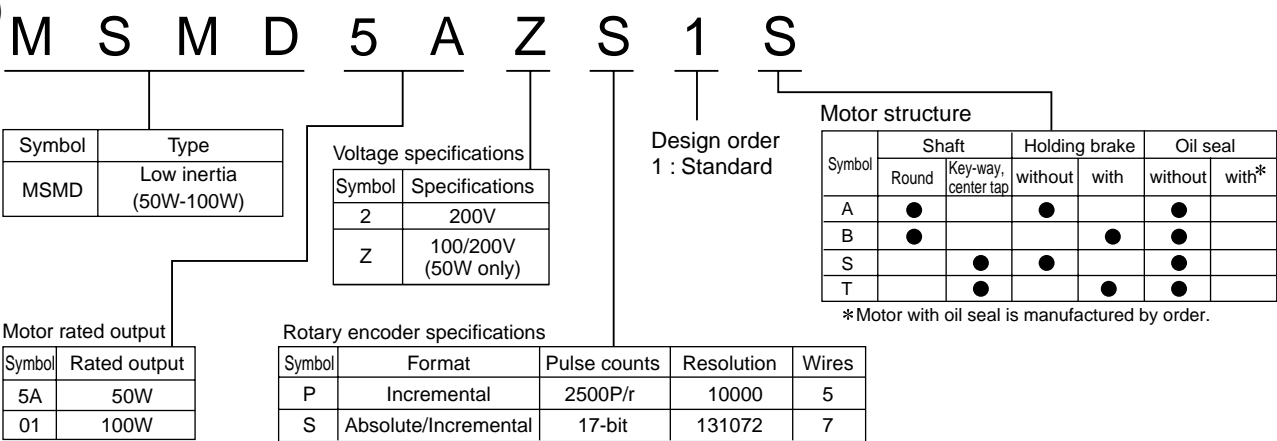

Torque characteristics at AC200V of power voltage

(Dotted line represents the torque at 10% less supply voltage.)

MSMD5AZ□1□

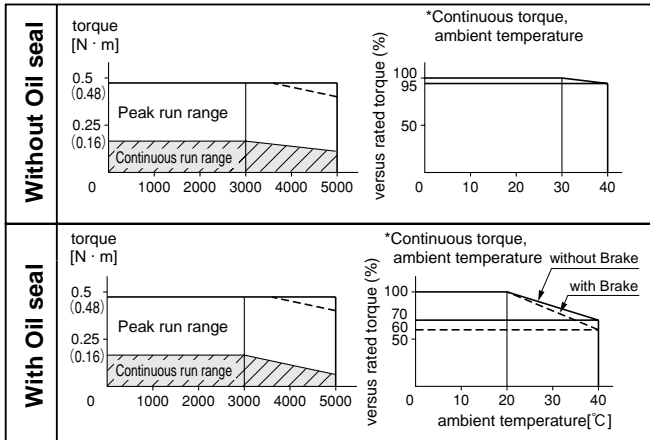

MSMD012□1□

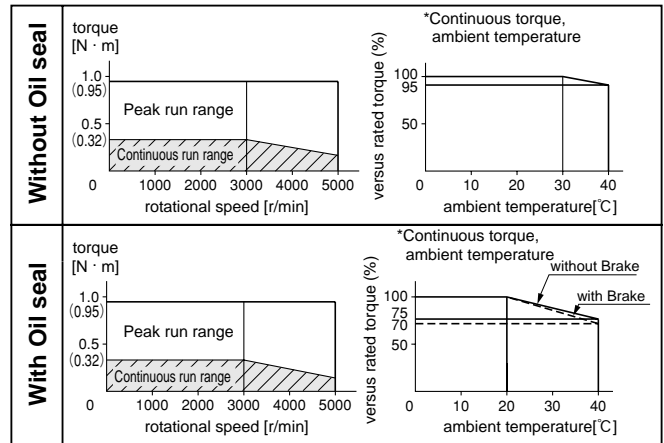

*When you lower the torque limit setup (Pr5E and 5F), running range at high speed might be lowered as well.

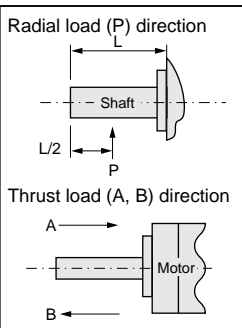
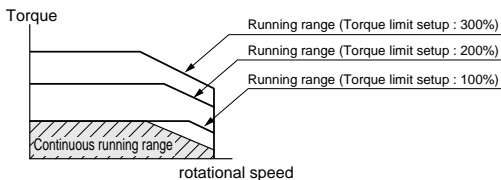

Note) 1. Regenerative brake frequency represents the frequency of the motor's stops from the rated speed with deceleration without load.

- If the load is connected, frequency will be defines as $1/(m+1)$, where m =load moment of inertia/rotor moment of inertia.
- When the motor speed exceeds the rated speed, regenerative brake frequency is in inverse proportion to the square of (running speed/rated speed).
- Power supply voltage is AC230V (at 200V of the main voltage).
If the supply voltage fluctuates, frequency is in inverse proportion to the square of (Running supply voltage/230) relative to the value in the table.
- When regeneration occurs continuously such cases as running speed frequently changes or vertical feeding, consult us or a dealer.
- 2. If the effective torque is within the rated torque, there is no limit in generative brake.
- 3. Consult us or a dealer if the load moment of inertia exceeds the specified value.
- 4. Specified releasing time is obtained with the use of surge absorber for brake (Z15D271 by Ishizuka Electronic or equivalent).
() represents the actually measured value using a diode (200V, 1A or equivalent)

Motor Specifications and Ratings 200V MSMD

200W to 750W Low inertia Small Capacity

		AC200V							
Motor model		MSMD		022P1□	022S1□	042P1□	042S1□	082P1□	082S1□
Applicable driver	Model No.	A4 series	MADDT1207		MBDDT2210		MCDDT3520		
		A4P series	MADDT1207P		MBDDT2210P		MCDDT3520P		
	Frame symbol		Frame A		Frame B		Frame C		
Power supply capacity (kVA)		0.5		0.9		1.3			
Rated output (W)		200		400		750			
Rated torque (N · m)		0.64		1.3		2.4			
Momentary Max. peak torque (N · m)		1.91		3.8		7.1			
Rated current (Arms)		1.6		2.6		4.0			
Max. current (Ao-p)		6.9		11.0		17.0			
Regenerative brake frequency (times/min) Note)1	Without option	No limit		Note)2					
	DV0P4283	No limit		Note)2					
Rated rotational speed (r/min)		3000							
Max. rotational speed (r/min)		5000					4500		
Moment of inertia of rotor (x10 ⁻⁴ kg · m ²)	Without brake	0.14		0.26		0.87			
	With brake	0.16		0.28		0.97			
Recommended moment of inertia ratio of the load and the rotor Note)3		Smaller than 30 times					Smaller than 20 times		
Rotary encoder specifications		2500P/r Incremental	17-bit Absolute/ Incremental	2500P/r Incremental	17-bit Absolute/ Incremental	2500P/r Incremental	17-bit Absolute/ Incremental		
		Resolution per single turn	10000	131072	10000	131072	10000	131072	
Protective enclosure rating		IP65 (except shaft through hole and cable end connector)							
Environment	Ambient temperature	0 to 40°C (free from freezing), Storage : -20 to + 80°C							
	Ambient humidity	85%RH or lower (free from condensing)							
	Installation location	Indoors (no direct sunlight), free from corrosive gas, inflammable gas, oil mist and dust							
	Altitude	1000m or lower							
	Vibration resistance	49m/s ² or less							
Mass (kg), () represents holding brake type		0.82 (1.3)		1.2 (1.7)		2.3 (3.1)			

Brake specifications (This brake will be released when it is energized. Do not use this for braking the motor in motion.)			
Static friction torque (N · m)	1.27		2.45
Engaging time (ms)	50		70
Releasing time (ms) Note)4	15 (—)		20 (—)
Exciting current (DC) (A)	0.36		0.42
Releasing voltage	DC1V or more		
Exciting voltage	DC 24 V ± 5%		

Permissible load			
During assembly	Radial load P-direction (N)	392	686
	Thrust load A-direction (N)	147	294
	Thrust load B-direction (N)	196	392
During operation	Radial load P-direction (N)	245	392
	Thrust load A-direction (N)	98	147
	Thrust load B-direction (N)	98	147

For motor dimensions, refer to page A4-89 , and for the diver, refer to pages A4-22,23 and A4-45,46.

Model designation MSMD series, 200W to 750W

e.g.)

M S M D 0 2 2 S 1 S

Symbol	Type
MSMD	Low inertia (200W-750W)

Voltage specifications	
Symbol	Specifications
2	200V

Design order
1 : Standard

Motor structure

Symbol	Shaft		Holding brake		Oil seal	
	Round	Key-way, center tap	without	with	without	with*
A	●		●		●	
B	●			●	●	
S		●	●		●	
T		●		●	●	

*Motor with oil seal is manufactured by order.

Motor rated output	
Symbol	Rated output
02	200W
04	400W
08	750W

Rotary encoder specifications

Symbol	Format	Pulse counts	Resolution	Wires
P	Incremental	2500P/r	10000	5
S	Absolute/Incremental	17-bit	131072	7

Torque characteristics at AC200V of power voltage

(Dotted line represents the torque at 10% less supply voltage.)

MSMD022□1□

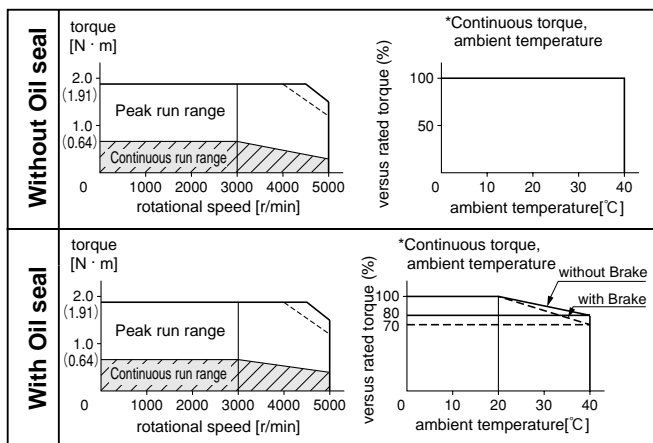

MSMD042□1□

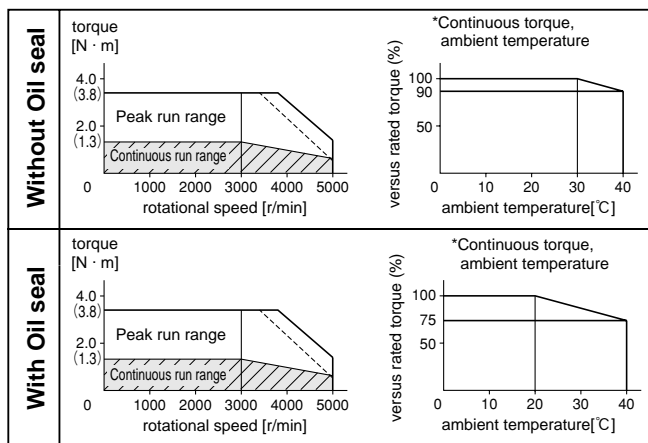

MSMD082□1□

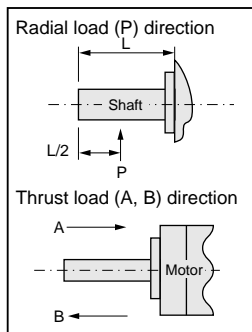
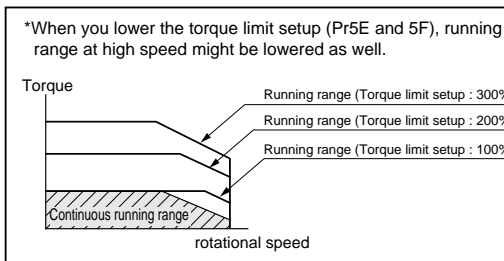
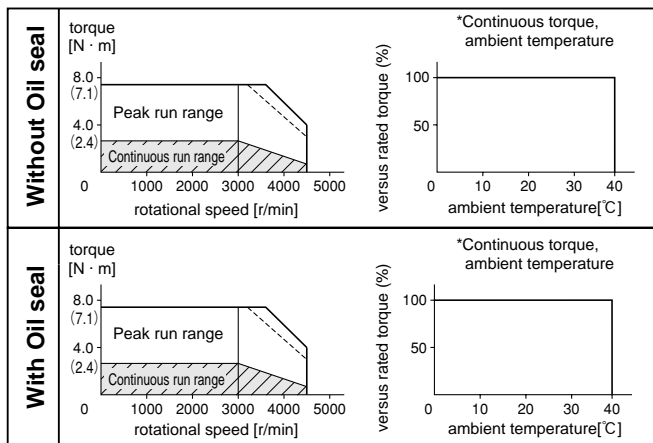

- Note) 1. Regenerative brake frequency represents the frequency of the motor's stops from the rated speed with deceleration without load.
- If the load is connected, frequency will be defined as $1/(m+1)$, where m =load moment of inertia/rotor moment of inertia.
 - When the motor speed exceeds the rated speed, regenerative brake frequency is in inverse proportion to the square of (running speed/rated speed).
 - Power supply voltage is AC230V (at 200V of the main voltage).
- If the supply voltage fluctuates, frequency is in inverse proportion to the square of (Running supply voltage/230) relative to the value in the table.
- When regeneration occurs continuously such cases as running speed frequently changes or vertical feeding, consult us or a dealer.
2. If the effective torque is within the rated torque, there is no limit in generative brake.
 3. Consult us or a dealer if the load moment of inertia exceeds the specified value.
 4. Specified releasing time is obtained with the use of surge absorber for brake (Z15D271 by Ishizuka Electronic or equivalent). () represents the actually measured value using a diode (200V, 1A or equivalent)

Motor Specifications and Ratings 100V MQMA 100W to 400W Low inertia, Flat, Small Capacity

		AC100V							
Motor model		MQMA		011P1□	011S1□	021P1□	021S1□	041P1□	041S1□
Applicable driver	Model No.	A4 series	MADDT1107		MBDDT2110		MCDDT3120		
		A4P series	MADDT1107P		MBDDT2110P		MCDDT3120P		
	Frame symbol	Frame A		Frame B		Frame C			
Power supply capacity (kVA)		0.4		0.5		1.0			
Rated output (W)		100		200		400			
Rated torque (N · m)		0.32		0.64		1.3			
Momentary Max. peak torque (N · m)		0.95		1.91		3.82			
Rated current (Arms)		1.6		2.5		4.4			
Max. current (Ao-p)		6.9		10.5		18.6			
Regenerative brake frequency (times/min) Note)1	Without option			No limit Note)2					
	DV0P4280	No limit Note)2							
	DV0P4282					No limit Note)2			
	DV0P4283			No limit Note)2					
Rated rotational speed (r/min)				3000					
Max. rotational speed (r/min)				5000		4500			
Moment of inertia of rotor (x10 ⁻⁴ kg · m ²)	Without brake	0.09	0.10	0.34	0.35	0.64	0.65		
	With brake	0.12	0.13	0.42	0.43	0.72	0.73		
Recommended moment of inertia ratio of the load and the rotor Note)3				Smaller than 20 times					
Rotary encoder specifications		2500P/r Incremental	17-bit Absolute/ Incremental	2500P/r Incremental	17-bit Absolute/ Incremental	2500P/r Incremental	17-bit Absolute/ Incremental		
Resolution per single turn		10000	131072	10000	131072	10000	131072		
Protective enclosure rating				IP65 (except shaft through hole and cable end connector)					
Environment	Ambient temperature			0 to 40°C (free from freezing), Storage : -20 to + 80°C					
	Ambient humidity			85%RH or lower (free from condensing)					
	Installation location			Indoors (no direct sunlight), free from corrosive gas, inflammable gas, oil mist and dust					
	Altitude			1000m or lower					
	Vibration resistance	49m/s ² or less	24m/s ² or less	49m/s ² or less	24m/s ² or less	49m/s ² or less	24m/s ² or less		
Mass (kg), () represents holding brake type		0.65 (0.90)	0.75 (1.0)	1.3 (2.0)	1.4 (2.1)	1.8 (2.5)	1.9 (2.6)		

Brake specifications (This brake will be released when it is energized. Do not use this for braking the motor in motion.)		
Static friction torque (N · m)	0.29	1.27
Engaging time (ms)	50	60
Releasing time (ms) Note)4	15 (100)	15 (100)
Exciting current (DC) (A)	0.29	0.41
Releasing voltage	DC1V or more	
Exciting voltage	DC 24 V ± 5%	

Permissible load			
During assembly	Radial load P-direction (N)	147	392
	Thrust load A-direction (N)	88	147
	Thrust load B-direction (N)	117	196
During operation	Radial load P-direction (N)	68	245
	Thrust load A-direction (N)	58	98
	Thrust load B-direction (N)	58	98

For motor dimensions, refer to page A4-90 , and for the diver, refer to pages A4-22,23 and A4-45,46.

Model designation MQMA series, 100W to 400W

e.g.)

M Q M A 0 1 1 S 1 S

Symbol	Type
MQMA	Low inertia (100W-400W)

Voltage specifications	
Symbol	Specifications
1	100V

Design order 1 : Standard

Motor structure

Symbol	Shaft		Holding brake		Oil seal	
	Round	Key-way, center tap	without	with	without	with*
A	●		●		●	
B	●			●	●	
S		●	●		●	
T		●		●	●	

*Motor with oil seal is manufactured by order.

Motor rated output

Symbol	Rated output
01	100W
02	200W
04	400W

Rotary encoder specifications

Symbol	Format	Pulse counts	Resolution	Wires
P	Incremental	2500P/r	10000	5
S	Absolute/Incremental	17-bit	131072	7

Torque characteristics at AC100V of power voltage

(Dotted line represents the torque at 10% less supply voltage.)

MQMA011□1□

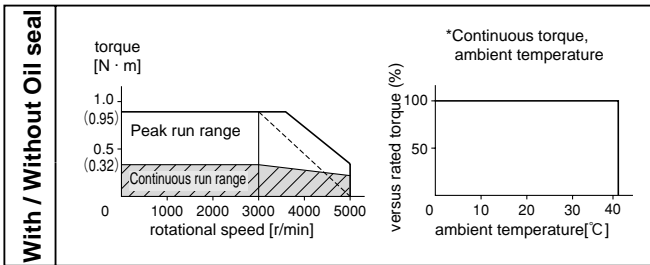

MQMA021□1□

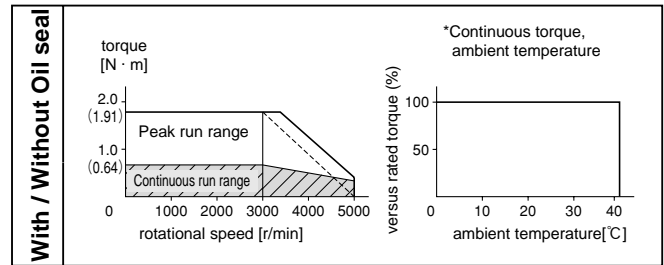

MQMA041□1□

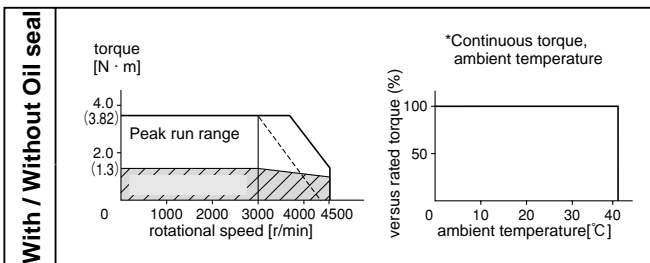

*When you lower the torque limit setup (Pr5E and 5F), running range at high speed might be lowered as well.

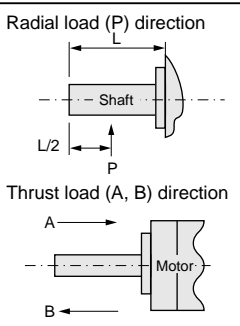
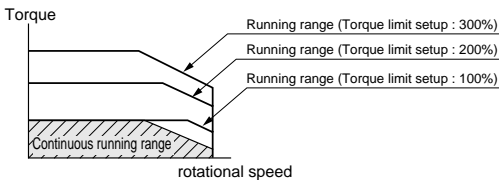

- Note) 1. Regenerative brake frequency represents the frequency of the motor's stops from the rated speed with deceleration without load.
- If the load is connected, frequency will be defined as $1/(m+1)$, where m =load moment of inertia/rotor moment of inertia.
 - When the motor speed exceeds the rated speed, regenerative brake frequency is in inverse proportion to the square of (running speed/rated speed).
 - Power supply voltage is AC115V (at 100V of the main voltage).
If the supply voltage fluctuates, frequency is in inverse proportion to the square of (Running supply voltage/115) relative to the value in the table.
 - When regeneration occurs continuously such cases as running speed frequently changes or vertical feeding, consult us or a dealer.
2. If the effective torque is within the rated torque, there is no limit in generative brake.
3. Consult us or a dealer if the load moment of inertia exceeds the specified value.
4. Specified releasing time is obtained with the use of surge absorber for brake (Z15D151 by Ishizuka Electronic or equivalent).
() represents the actually measured value using a diode (200V, 1A or equivalent)

Motor Specifications and Ratings 200V MQMA 100W to 400W Low inertia, Flat, Small Capacity

		AC200V							
Motor model		MQMA		012P1□	012S1□	022P1□	022S1□	042P1□	042S1□
Applicable driver	Model No.	A4 series	MADDT1205		MADDT1207		MBDDT2210		
		A4P series	MADDT1205P		MADDT1207P		MBDDT2210P		
	Frame symbol		Frame A				Frame B		
Power supply capacity (kVA)		0.4		0.5		1.0			
Rated output (W)		100		200		400			
Rated torque (N · m)		0.32		0.64		1.3			
Momentary Max. peak torque (N · m)		0.95		1.91		3.82			
Rated current (Arms)		1.0		1.6		2.5			
Max. current (Ao-p)		4.3		6.8		10.5			
Regenerative brake frequency (times/min) Note)1	Without option			No limit Note)2					
	DV0P4283			No limit Note)2					
Rated rotational speed (r/min)				3000					
Max. rotational speed (r/min)				5000					
Moment of inertia of rotor ($\times 10^{-4}$ kg · m ²)	Without brake	0.090	0.100	0.340	0.350	0.640	0.650		
	With brake	0.120	0.130	0.420	0.430	0.720	0.730		
Recommended moment of inertia ratio of the load and the rotor Note)3		Smaller than 20 times							
Rotary encoder specifications		2500P/r Incremental	17-bit Absolute/ Incremental	2500P/r Incremental	17-bit Absolute/ Incremental	2500P/r Incremental	17-bit Absolute/ Incremental		
Resolution per single turn		10000	131072	10000	131072	10000	131072		
Protective enclosure rating		IP65 (except shaft through hole and cable end connector)							
Environment	Ambient temperature	0 to 40°C (free from freezing), Storage : -20 to + 80°C							
	Ambient humidity	85%RH or lower (free from condensing)							
	Installation location	Indoors (no direct sunlight), free from corrosive gas, inflammable gas, oil mist and dust							
	Altitude	1000m or lower							
	Vibration resistance	49m/s ² or less	24m/s ² or less	49m/s ² or less	24m/s ² or less	49m/s ² or less	24m/s ² or less		
Mass (kg), () represents holding brake type		0.65 (0.90)	0.75 (1.0)	1.3 (2.0)	1.4 (2.1)	1.8 (2.5)	1.9 (2.6)		

Brake specifications (This brake will be released when it is energized. Do not use this for braking the motor in motion.)		
Static friction torque (N · m)	0.29	1.27
Engaging time (ms)	50	60
Releasing time (ms) Note)4	15 (100)	15 (100)
Exciting current (DC) (A)	0.29	0.41
Releasing voltage	DC1V or more	
Exciting voltage	DC 24 V \pm 10%	

Permissible load			
During assembly	Radial load P-direction (N)	147	392
	Thrust load A-direction (N)	88	147
	Thrust load B-direction (N)	117	196
During operation	Radial load P-direction (N)	68	245
	Thrust load A-direction (N)	58	98
	Thrust load B-direction (N)	58	98

For motor dimensions, refer to page A4-90 , and for the diver, refer to pages A4-22 and 45.

Model designation MQMA series, 100W to 400W

e.g.)

M Q M A 0 1 2 S 1 S

Symbol	Type
MQMA	Low inertia (100W-400W)

Voltage specifications	
Symbol	Specifications
2	200V

Design order
1 : Standard

Motor structure

Symbol	Shaft		Holding brake		Oil seal	
	Round	Key-way, center tap	without	with	without	with*
A	●		●		●	
B	●			●	●	
S		●	●		●	
T		●		●	●	

*Motor with oil seal is manufactured by order.

Motor rated output

Symbol	Rated output
01	100W
02	200W
04	400W

Rotary encoder specifications

Symbol	Format	Pulse counts	Resolution	Wires
P	Incremental	2500P/r	10000	5
S	Absolute/Incremental	17-bit	131072	7

Torque characteristics at AC200V of power voltage

(Dotted line represents the torque at 10% less supply voltage.)

MQMA012□1□

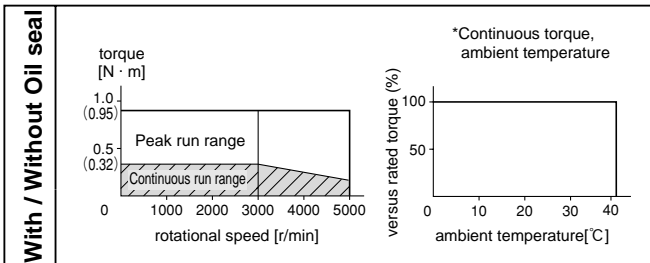

MQMA022□1□

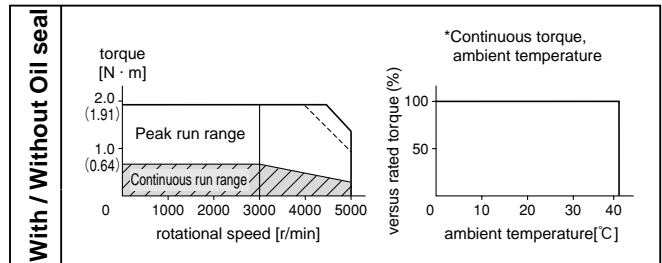

MQMA042□1□

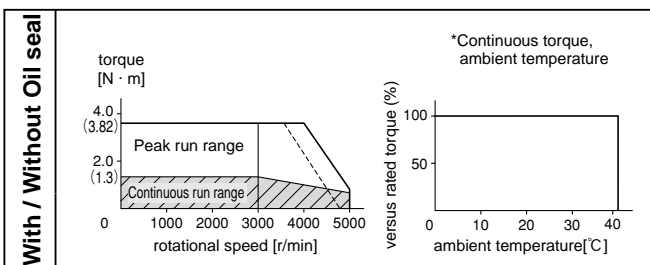

*When you lower the torque limit setup (Pr5E and 5F), running range at high speed might be lowered as well.

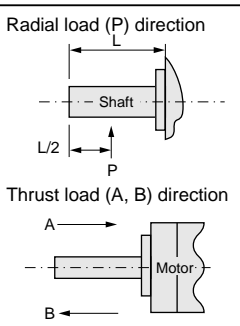
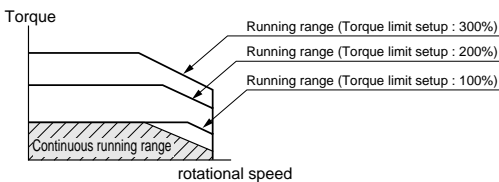

- Note) 1. Regenerative brake frequency represents the frequency of the motor's stops from the rated speed with deceleration without load.
- If the load is connected, frequency will be defined as $1/(m+1)$, where m =load moment of inertia/rotor moment of inertia.
 - When the motor speed exceeds the rated speed, regenerative brake frequency is in inverse proportion to the square of (running speed/rated speed).
 - Power supply voltage is AC230V (at 200V of the main voltage).
If the supply voltage fluctuates, frequency is in inverse proportion to the square of (Running supply voltage/230) relative to the value in the table.
 - When regeneration occurs continuously such cases as running speed frequently changes or vertical feeding, consult us or a dealer.
2. If the effective torque is within the rated torque, there is no limit in generative brake.
 3. Consult us or a dealer if the load moment of inertia exceeds the specified value.
 4. Specified releasing time is obtained with the use of surge absorber for brake (Z15D151 by Ishizuka Electronic or equivalent).
 () represents the actually measured value using a diode (200V, 1A or equivalent)

Motor Specifications and Ratings 200V MSMA

1.0kW to 2.0kW Low inertia, Medium Capacity

		AC200V							
Motor model		MSMA		102P1 <input type="checkbox"/>	102S1 <input type="checkbox"/>	152P1 <input type="checkbox"/>	152S1 <input type="checkbox"/>	202P1 <input type="checkbox"/>	202S1 <input type="checkbox"/>
Applicable driver	Model No.	A4 series	MDDDT5540				MEDDT7364		
		A4P series	MDDDT5540P				MEDDT7364P		
	Frame symbol	Frame D				Frame E			
Power supply capacity (kVA)		1.8			2.3		3.3		
Rated output (W)		1000			1500		2000		
Rated torque (N · m)		3.18			4.77		6.36		
Momentary Max. peak torque (N · m)		9.5			14.3		19.1		
Rated current (Arms)		7.2			9.4		13.0		
Max. current (Ao-p)		30			40		56		
Regenerative brake frequency (times/min) Note1	Without option	No limit Note)2							
	DV0P4284	No limit Note)2				—			
	DV0P4285×2	—				No limit Note)2			
Rated rotational speed (r/min)		3000							
Max. rotational speed (r/min)		5000							
Moment of inertia of rotor (x10 ⁻⁴ kg · m ²)	Without brake	1.69			2.59		3.46		
	With brake	1.88			2.84		3.81		
Recommended moment of inertia ratio of the load and the rotor Note)3		Smaller than 15 times							
Rotary encoder specifications		2500P/r Incremental	17-bit Absolute/ Incremental	2500P/r Incremental	17-bit Absolute/ Incremental	2500P/r Incremental	17-bit Absolute/ Incremental	2500P/r Incremental	17-bit Absolute/ Incremental
Resolution per single turn		10000	131072	10000	131072	10000	131072	10000	131072
Protective enclosure rating		IP65 (except shaft through hole and cable end connector)							
Environment	Ambient temperature	0 to 40°C (free from freezing), Storage : -20 to + 80°C							
	Ambient humidity	85%RH or lower (free from condensing)							
	Installation location	Indoors (no direct sunlight), free from corrosive gas, inflammable gas, oil mist and dust							
	Altitude	1000m or lower							
	Vibration resistance	49m/s ² or less							
Mass (kg), () represents holding brake type		4.5 (5.1)			5.1 (6.5)		6.5 (7.9)		

Brake specifications (This brake will be released when it is energized. Do not use this for braking the motor in motion.)				
Static friction torque (N · m)	4.9		7.8	
Engaging time (ms)	50		50	
Releasing time (ms) Note)4	15 (100)		15 (100)	
Exciting current (DC) (A)	0.74		0.81	
Releasing voltage	DC2V or more			
Exciting voltage	DC 24 V ± 10%			

Permissible load			
During assembly	Radial load P-direction (N)	686	980
	Thrust load A-direction (N)	392	588
	Thrust load B-direction (N)	490	686
During operation	Radial load P-direction (N)	392	490
	Thrust load A-direction (N)	147	196
	Thrust load B-direction (N)	147	196

For motor dimensions, refer to page A4-91 , and for the diver, refer to pages A4-23,24 and A4-46,47.

Model designation MSMA series, 1.0kW to 2.0kW

e.g.)

M S M A 1 0 2 S 1 G

Symbol	Type
MSMA	Low inertia (1.0kW-2.0kW)

Voltage specifications	
Symbol	Specifications
2	200V

Design order
1 : Standard

Motor structure

Symbol	Shaft		Holding brake		Oil seal	
	Round	Key-way	without	with	without	with
C	●		●			●
D	●			●		●
G		●	●			●
H		●		●		●

Products are standard stock items or build to order items. See index (page F31).

Motor rated output	
Symbol	Rated output
10	1.0kW
15	1.5kW
20	2.0kW

Rotary encoder specifications

Symbol	Format	Pulse counts	Resolution	Wires
P	Incremental	2500P/r	10000	5
S	Absolute/Incremental	17-bit	131072	7

Torque characteristics at AC200V of power voltage

(Dotted line represents the torque at 10% less supply voltage.)

MSMA102□1□

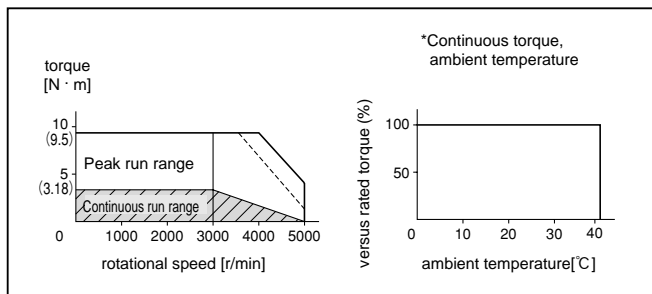

MSMA152□1□

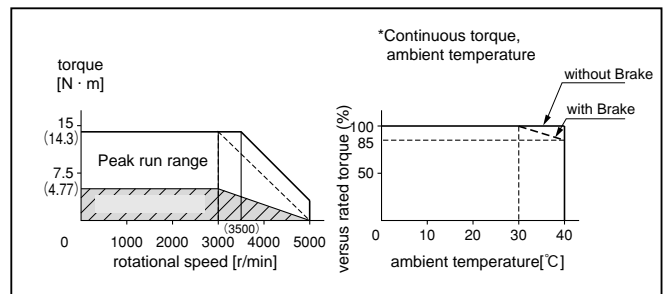

MSMA202□1□

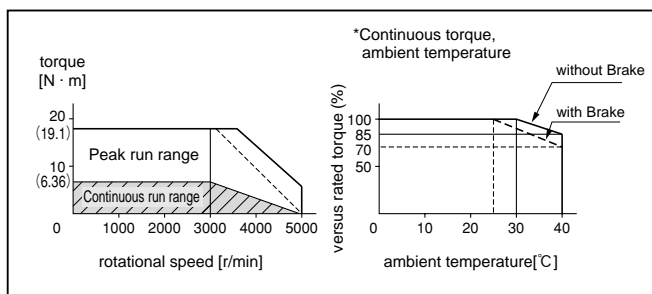

*When you lower the torque limit setup (Pr5E and 5F), running range at high speed might be lowered as well.

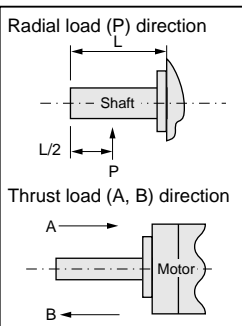
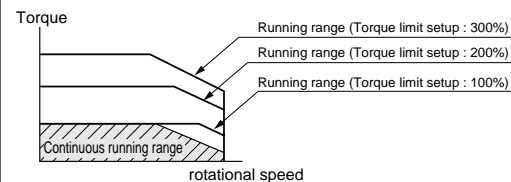

- Note) 1. Regenerative brake frequency represents the frequency of the motor's stops from the rated speed with deceleration without load.
- If the load is connected, frequency will be defined as $1/(m+1)$, where m =load moment of inertia/rotor moment of inertia.
 - When the motor speed exceeds the rated speed, regenerative brake frequency is in inverse proportion to the square of (running speed/rated speed).
 - Power supply voltage is AC230V (at 200V of the main voltage).
 - If the supply voltage fluctuates, frequency is in inverse proportion to the square of (Running supply voltage/230) relative to the value in the table.
 - When regeneration occurs continuously such cases as running speed frequently changes or vertical feeding, consult us or a dealer.
2. If the effective torque is within the rated torque, there is no limit in generative brake.
3. Consult us or a dealer if the load moment of inertia exceeds the specified value.
4. Specified releasing time is obtained with the use of surge absorber for brake (Z15D151 by Ishizuka Electronic or equivalent).
- () represents the actually measured value using a diode (200V, 1A or equivalent)

Motor Specifications and Ratings 200V MSMA

3.0kW to 5.0kW Low inertia, Medium Capacity

		AC200V								
Motor model		MSMA		302P1□	302S1□	402P1□	402S1□	502P1□	502S1□	
Applicable driver	Model No.	A4 series	MFDDTA390			MFDDTB3A2				
		A4P series	MFDDTA390P			MFDDTB3A2P				
	Frame symbol		Frame F							
Power supply capacity (kVA)		4.5			6.0		7.5			
Rated output (W)		3000			4000		5000			
Rated torque (N · m)		9.54			12.6		15.8			
Momentary Max. peak torque (N · m)		28.6			37.9		47.6			
Rated current (Arms)		18.6			24.7		28.5			
Max. current (Ao-p)		80			105		120			
Regenerative brake frequency (times/min) Note)1	Without option	No limit Note)2					326			
	DV0P4285×2	No limit Note)2								
Rated rotational speed (r/min)		3000								
Max. rotational speed (r/min)		5000			4500					
Moment of inertia of rotor (x10 ⁻⁴ kg · m ²)	Without brake	6.77			12.7		17.8			
	With brake	7.45			14.1		19.7			
Recommended moment of inertia ratio of the load and the rotor Note)3		Smaller than 15 times								
Rotary encoder specifications		2500P/r Incremental	17-bit Absolute/ Incremental	2500P/r Incremental	17-bit Absolute/ Incremental	2500P/r Incremental	17-bit Absolute/ Incremental	2500P/r Incremental	17-bit Absolute/ Incremental	
		Resolution per single turn	10000	131072	10000	131072	10000	131072	10000	131072
Protective enclosure rating		IP65 (except shaft through hole and cable end connector)								
Environment	Ambient temperature	0 to 40°C (free from freezing), Storage : -20 to + 80°C								
	Ambient humidity	85%RH or lower (free from condensing)								
	Installation location	Indoors (no direct sunlight), free from corrosive gas, inflammable gas, oil mist and dust								
	Altitude	1000m or lower								
	Vibration resistance	49m/s ² or less								
Mass (kg), () represents holding brake type		9.3 (11.0)			12.9 (14.8)		17.3 (19.2)			

Brake specifications (This brake will be released when it is energized. Do not use this for braking the motor in motion.)				
Static friction torque (N · m)	11.8		16.1	
Engaging time (ms)	80		110	
Releasing time (ms) Note)4	15 (100)		50 (130)	
Exciting current (DC) (A)	0.81		0.90	
Releasing voltage	DC2V or more			
Exciting voltage	DC 24 V ± 10%			

Permissible load				
During assembly	Radial load P-direction (N)	980		
	Thrust load A-direction (N)	588		
	Thrust load B-direction (N)	686		
During operation	Radial load P-direction (N)	490		784
	Thrust load A-direction (N)	196		343
	Thrust load B-direction (N)	196		343

For motor dimensions, refer to page A4-92 , and for the diver, refer to pages A4-24 and 47.

Model designation MSMA series, 3.0kW to 5.0kW

e.g.)

M S M A 3 0 2 S 1 G

Symbol	Type
MSMA	Low inertia (3.0kW-5.0kW)

Voltage specifications	
Symbol	Specifications
2	200V

Design order
1 : Standard

Motor structure

Symbol	Shaft		Holding brake		Oil seal	
	Round	Key-way	without	with	without	with
C	●		●			●
D	●			●		●
G		●	●			●
H		●		●		●

Motor rated output	
Symbol	Rated output
30	3.0kW
40	4.0kW
50	5.0kW

Rotary encoder specifications					
Symbol	Format	Pulse counts	Resolution	Wires	
P	Incremental	2500P/r	10000	5	
S	Absolute/Incremental	17-bit	131072	7	

Products are standard stock items or build to order items. See index (page F31).

Torque characteristics at AC200V of power voltage

(Dotted line represents the torque at 10% less supply voltage.)

MSMA302□1□

MSMA402□1□

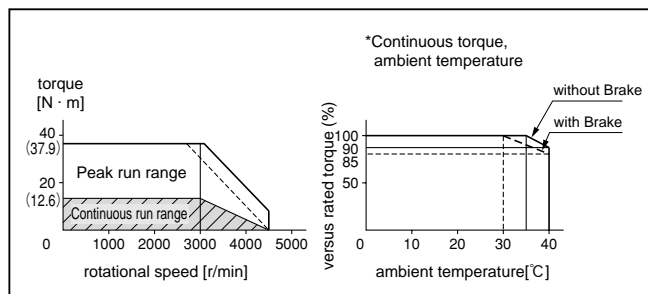
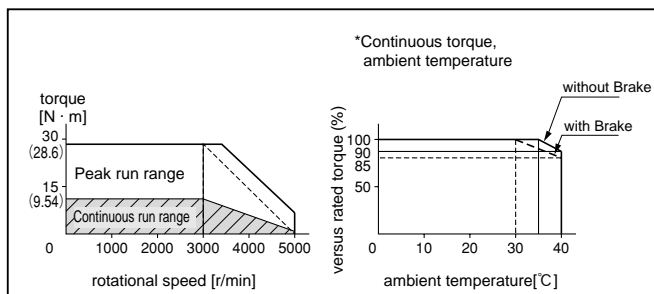

MSMA502□1□

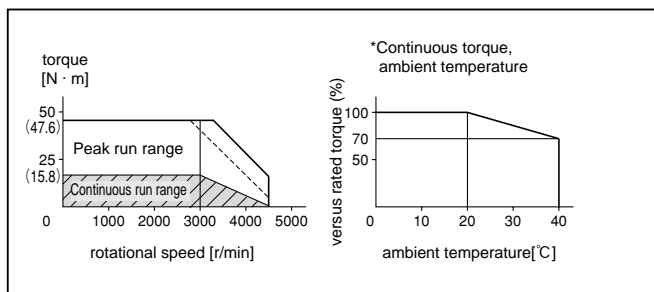

*When you lower the torque limit setup (Pr5E and 5F), running range at high speed might be lowered as well.

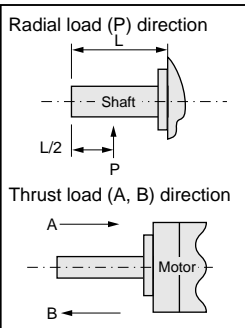
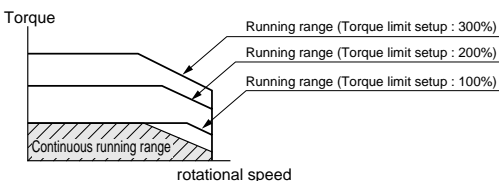

Note) 1. Regenerative brake frequency represents the frequency of the motor's stops from the rated speed with deceleration without load.

- If the load is connected, frequency will be defined as $1/(m+1)$, where m =load moment of inertia/rotor moment of inertia.
 - When the motor speed exceeds the rated speed, regenerative brake frequency is in inverse proportion to the square of (running speed/rated speed).
 - Power supply voltage is AC230V (at 200V of the main voltage).
If the supply voltage fluctuates, frequency is in inverse proportion to the square of (Running supply voltage/230) relative to the value in the table.
 - When regeneration occurs continuously such cases as running speed frequently changes or vertical feeding, consult us or a dealer.
2. If the effective torque is within the rated torque, there is no limit in generative brake.
 3. Consult us or a dealer if the load moment of inertia exceeds the specified value.
 4. Specified releasing time is obtained with the use of surge absorber for brake (Z15D151 by Ishizuka Electronic or equivalent).
() represents the actually measured value using a diode (200V, 1A or equivalent)

Motor Specifications and Ratings 200V MDMA

1.0kW to 1.5kW Low inertia, Medium Capacity

		AC200V					
Motor model		MDMA		102P1 <input type="checkbox"/>	102S1 <input type="checkbox"/>	152P1 <input type="checkbox"/>	152S1 <input type="checkbox"/>
Applicable driver	Model No.	A4 series	MDDDT3530		MDDDT5540		
		A4P series	MDDDT3530P		MDDDT5540P		
	Frame symbol		Frame D				
Power supply capacity (kVA)		1.8			2.3		
Rated output (W)		1000			1500		
Rated torque (N · m)		4.8			7.15		
Momentary Max. peak torque (N · m)		14.4			21.5		
Rated current (Arms)		5.6			9.4		
Max. current (Ao-p)		24			40		
Regenerative brake frequency (times/min) Note)1	Without option	No limit		Note)2			
	DV0P4284	No limit		Note)2			
Rated rotational speed (r/min)		2000					
Max. rotational speed (r/min)		3000					
Moment of inertia of rotor ($\times 10^{-4}$ kg · m ²)	Without brake	6.17			11.2		
	With brake	6.79			12.3		
Recommended moment of inertia ratio of the load and the rotor Note)3		Smaller than 10 times					
Rotary encoder specifications		2500P/r Incremental	17-bit Absolute/ Incremental	2500P/r Incremental	17-bit Absolute/ Incremental		
	Resolution per single turn	10000	131072	10000	131072		
Protective enclosure rating		IP65 (except shaft through hole and cable end connector)					
Environment	Ambient temperature	0 to 40°C (free from freezing), Storage : -20 to + 80°C					
	Ambient humidity	85%RH or lower (free from condensing)					
	Installation location	Indoors (no direct sunlight), free from corrosive gas, inflammable gas, oil mist and dust					
	Altitude	1000m or lower					
	Vibration resistance	49m/s ² or less					
Mass (kg), () represents holding brake type		6.8 (8.7)			8.5 (10.1)		

Brake specifications (This brake will be released when it is energized. Do not use this for braking the motor in motion.)					
Static friction torque (N · m)		4.9		13.7	
Engaging time (ms)		80		100	
Releasing time (ms) Note)4		70 (200)		50 (130)	
Exciting current (DC) (A)		0.59		0.79	
Releasing voltage		DC2V or more			
Exciting voltage		DC 24 V \pm 10%			

Permissible load		
During assembly	Radial load P-direction (N)	980
	Thrust load A-direction (N)	588
	Thrust load B-direction (N)	686
During operation	Radial load P-direction (N)	490
	Thrust load A-direction (N)	196
	Thrust load B-direction (N)	196

For motor dimensions, refer to page A4-93 , and for the diver, refer to pages A4-23 and 46.

Model designation MDMA series, 1.0kW to 1.5kW

e.g.)

M D M A 1 0 2 S 1 G

Symbol	Type
MDMA	Middle inertia (1.0kW-1.5kW)

Voltage specifications	
Symbol	Specifications
2	200V

Design order
1 : Standard

Motor structure

Symbol	Shaft		Holding brake		Oil seal	
	Round	Key-way	without	with	without	with
C	●		●			●
D	●			●		●
G		●	●			●
H		●		●		●

Motor rated output	
Symbol	Rated output
10	1.0kW
15	1.5kW

Rotary encoder specifications				
Symbol	Format	Pulse counts	Resolution	Wires
P	Incremental	2500P/r	10000	5
S	Absolute/Incremental	17-bit	131072	7

Products are standard stock items or build to order items. See index (page F31).

Torque characteristics at AC200V of power voltage

(Dotted line represents the torque at 10% less supply voltage.)

MDMA102□1□

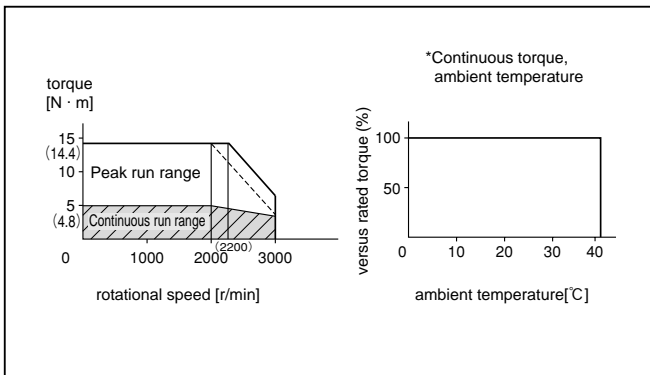

MDMA152□1□

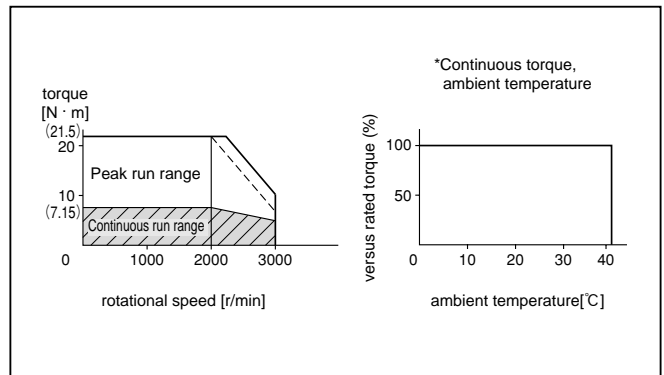

*When you lower the torque limit setup (Pr5E and 5F), running range at high speed might be lowered as well.

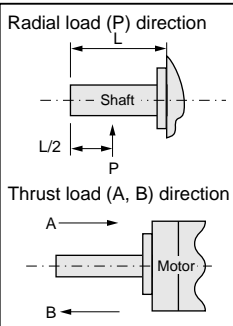
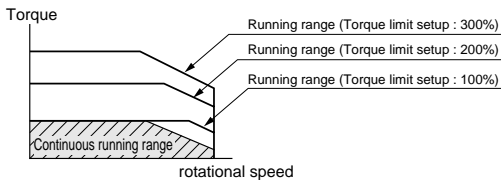

- Note) 1. Regenerative brake frequency represents the frequency of the motor's stops from the rated speed with deceleration without load.
- If the load is connected, frequency will be defined as $1/(m+1)$, where m =load moment of inertia/rotor moment of inertia.
 - When the motor speed exceeds the rated speed, regenerative brake frequency is in inverse proportion to the square of (running speed/rated speed).
 - Power supply voltage is AC230V (at 200V of the main voltage).
 - If the supply voltage fluctuates, frequency is in inverse proportion to the square of (Running supply voltage/230) relative to the value in the table.
 - When regeneration occurs continuously such cases as running speed frequently changes or vertical feeding, consult us or a dealer.
2. If the effective torque is within the rated torque, there is no limit in generative brake.
3. Consult us or a dealer if the load moment of inertia exceeds the specified value.
4. Specified releasing time is obtained with the use of surge absorber for brake (Z15D151 by Ishizuka Electronic or equivalent).
- () represents the actually measured value using a diode (200V, 1A or equivalent)

Motor Specifications and Ratings 200V MDMA

2.0kW to 3.0kW Middle inertia, Medium Capacity

		AC200V					
Motor model		MDMA		202P1 <input type="checkbox"/>	202S1 <input type="checkbox"/>	302P1 <input type="checkbox"/>	302S1 <input type="checkbox"/>
Applicable driver	Model No.	A4 series	MEDDT7364		MFDDTA390		
		A4P series	MEDDT7364P		MFDDTA390P		
	Frame symbol		Frame E		Frame F		
Power supply capacity (kVA)		3.3		4.5			
Rated output (W)		2000		3000			
Rated torque (N · m)		9.54		14.3			
Momentary Max. peak torque (N · m)		28.5		42.9			
Rated current (Arms)		12.3		17.8			
Max. current (Ao-p)		52		76			
Regenerative brake frequency (times/min) Note)1	Without option	No limit		Note)2			
	DV0P4285×2	No limit		Note)2			
Rated rotational speed (r/min)		2000		3000			
Max. rotational speed (r/min)		2000		3000			
Moment of inertia of rotor (x10 ⁻⁴ kg · m ²)	Without brake	15.2		22.3			
	With brake	16.7		24.6			
Recommended moment of inertia ratio of the load and the rotor Note)3		Smaller than 10 times					
Rotary encoder specifications		2500P/r Incremental	17-bit Absolute/ Incremental	2500P/r Incremental	17-bit Absolute/ Incremental		
		Resolution per single turn	10000	131072	10000	131072	
Protective enclosure rating		IP65 (except shaft through hole and cable end connector)					
Environment	Ambient temperature	0 to 40°C (free from freezing), Storage : -20 to + 80°C					
	Ambient humidity	85%RH or lower (free from condensing)					
	Installation location	Indoors (no direct sunlight), free from corrosive gas, inflammable gas, oil mist and dust					
	Altitude	1000m or lower					
	Vibration resistance	49m/s ² or less					
Mass (kg), () represents holding brake type		10.6 (12.5)		14.6 (16.5)			

Brake specifications (This brake will be released when it is energized. Do not use this for braking the motor in motion.)		
Static friction torque (N · m)	13.7	
Engaging time (ms)	100	
Releasing time (ms) Note)4	50 (130)	
Exciting current (DC) (A)	0.79	
Releasing voltage	DC2V or more	
Exciting voltage	DC 24 V ± 10%	

Permissible load			
During assembly	Radial load P-direction (N)	980	980
	Thrust load A-direction (N)	588	588
	Thrust load B-direction (N)	686	686
During operation	Radial load P-direction (N)	490	784
	Thrust load A-direction (N)	196	343
	Thrust load B-direction (N)	196	343

For motor dimensions, refer to page A4-94 , and for the diver, refer to pages A4-24 and 47.

Model designation MDMA series, 2.0kW to 3.0kW

e.g.)

M D M A 2 0 2 S 1 G

Symbol	Type
MDMA	Middle inertia (2.0kW-3.0kW)

Voltage specifications	
Symbol	Specifications
2	200V

Design order 1 : Standard

Motor structure

Symbol	Shaft		Holding brake		Oil seal	
	Round	Key-way	without	with	without	with
C	●		●			●
D	●			●		●
G		●	●			●
H		●		●		●

Motor rated output	
Symbol	Rated output
20	2.0kW
30	3.0kW

Rotary encoder specifications

Symbol	Format	Pulse counts	Resolution	Wires
P	Incremental	2500P/r	10000	5
S	Absolute/Incremental	17-bit	131072	7

Products are standard stock items or build to order items. See index (page F31).

Torque characteristics at AC200V of power voltage

(Dotted line represents the torque at 10% less supply voltage.)

MDMA202□1□

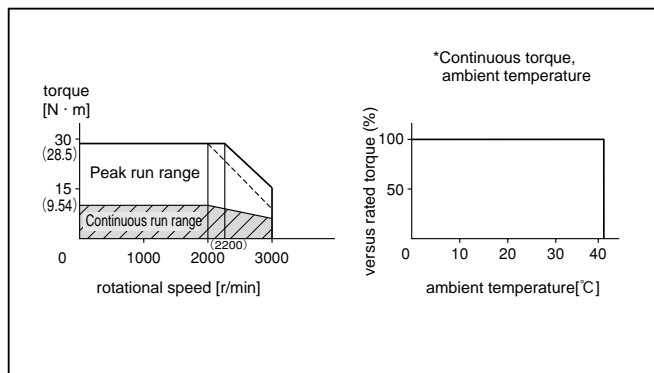

MDMA302□1□

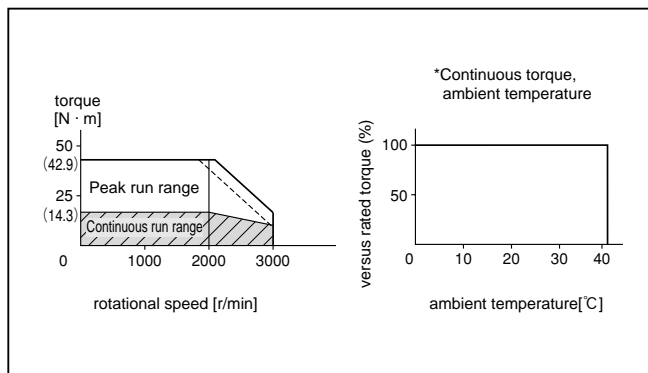

*When you lower the torque limit setup (Pr5E and 5F), running range at high speed might be lowered as well.

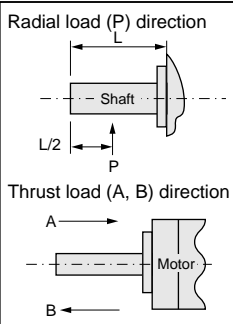
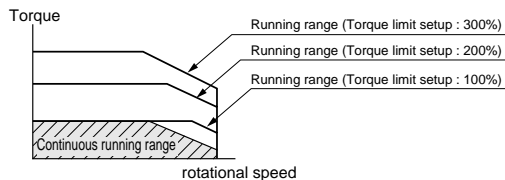

Note) 1. Regenerative brake frequency represents the frequency of the motor's stops from the rated speed with deceleration without load.

- If the load is connected, frequency will be defined as $1/(m+1)$, where m =load moment of inertia/rotor moment of inertia.
 - When the motor speed exceeds the rated speed, regenerative brake frequency is in inverse proportion to the square of (running speed/rated speed).
 - Power supply voltage is AC230V (at 200V of the main voltage).
If the supply voltage fluctuates, frequency is in inverse proportion to the square of (Running supply voltage/230) relative to the value in the table.
 - When regeneration occurs continuously such cases as running speed frequently changes or vertical feeding, consult us or a dealer.
2. If the effective torque is within the rated torque, there is no limit in regenerative brake.
 3. Consult us or a dealer if the load moment of inertia exceeds the specified value.
 4. Specified releasing time is obtained with the use of surge absorber for brake (Z15D151 by Ishizuka Electronic or equivalent).
() represents the actually measured value using a diode (200V, 1A or equivalent)

Motor Specifications and Ratings 200V MDMA

4.0kW to 7.5kW Middle inertia, Medium Capacity

		AC200V							
Motor model		MDMA		402P1□	402S1□	502P1□	502S1□	752P1□	752S1□
Applicable driver	Model No.	A4 series			MFDDTB3A2			MGDDTC3B4	
		A4P series			MFDDTB3A2P			—	
	Frame symbol	Frame F			Frame G				
Power supply capacity (kVA)		6.0			7.5			11	
Rated output (W)		4000			5000			7500	
Rated torque (N · m)		18.8			23.8			48	
Momentary Max. peak torque (N · m)		56.4			71.4			119	
Rated current (Arms)		23.4			28.0			46.6	
Max. current (Ao-p)		100.0			120.0			165.0	
Regenerative brake frequency (times/min) Note)1	Without option	250			94			No limit Note)2	
	DV0P4285×2	No limit Note)2			—			—	
	DV0P4285×4	—			—			No limit Note)2	
Rated rotational speed (r/min)		2000			1500				
Max. rotational speed (r/min)		3000			3000				
Moment of inertia of rotor (x10 ⁻⁴ kg · m ²)	Without brake	42.5			60.7			99.0	
	With brake	46.8			66.7			105.0	
Recommended moment of inertia ratio of the load and the rotor Note)3		Smaller than 10 times							
Rotary encoder specifications		2500P/r Incremental	17-bit Absolute/ Incremental	2500P/r Incremental	17-bit Absolute/ Incremental	2500P/r Incremental	17-bit Absolute/ Incremental		
	Resolution per single turn	10000	131072	10000	131072	10000	131072		
Protective enclosure rating		IP65 (except shaft through hole and cable end connector)							
Environment	Ambient temperature	0 to 40°C (free from freezing), Storage : -20 to + 80°C							
	Ambient humidity	85%RH or lower (free from condensing)							
	Installation location	Indoors (no direct sunlight), free from corrosive gas, inflammable gas, oil mist and dust							
	Altitude	1000m or lower							
	Vibration resistance	49m/s ² or less				24m/s ² or less			
Mass (kg), () represents holding brake type		18.8 (21.3)			25.0 (28.5)			41.0 (45.0)	

Brake specifications (This brake will be released when it is energized. Do not use this for braking the motor in motion.)			
Static friction torque (N · m)	21.5		58.8
Engaging time (ms)	90		150
Releasing time (ms) Note)4	35 (150)		50 (130)
Exciting current (DC) (A)	1.10		1.4
Releasing voltage	DC2V or more		
Exciting voltage	DC 24 V ± 10%		

Permissible load			
During assembly	Radial load P-direction (N)	1666	
	Thrust load A-direction (N)	784	
	Thrust load B-direction (N)	980	
During operation	Radial load P-direction (N)	784	
	Thrust load A-direction (N)	343	
	Thrust load B-direction (N)	343	

For motor dimensions, refer to page A4-95 , and for the diver, refer to pages A4-24,25 and 47.

Model designation MDMA series, 4.0kW to 7.5kW

e.g.)

M D M A 4 0 2 S 1 G

Symbol	Type
MDMA	Middle inertia (4.0kW-7.5kW)

Voltage specifications	
Symbol	Specifications
2	200V

Design order
1 : Standard

Motor structure

Symbol	Shaft		Holding brake		Oil seal	
	Round	Key-way	without	with	without	with
C	●		●			●
D	●			●		●
G		●	●			●
H		●		●		●

Products are standard stock items or build to order items. See index (page F31).

Motor rated output	
Symbol	Rated output
40	4.0kW
50	5.0kW
75	7.5kW

Rotary encoder specifications				
Symbol	Format	Pulse counts	Resolution	Wires
P	Incremental	2500P/r	10000	5
S	Absolute/Incremental	17-bit	131072	7

Torque characteristics at AC200V of power voltage

(Dotted line represents the torque at 10% less supply voltage.)

MDMA402□1□

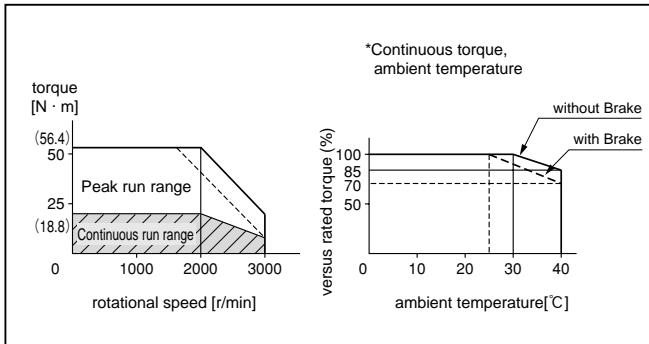

MDMA502□1□

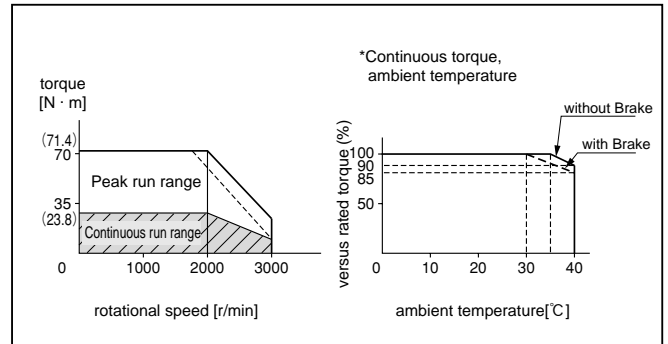

MDMA752□1□

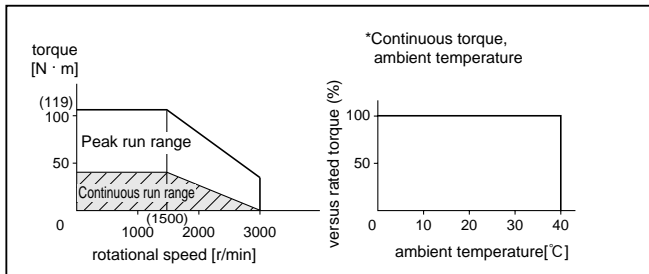

*When you lower the torque limit setup (Pr5E and 5F), running range at high speed might be lowered as well.

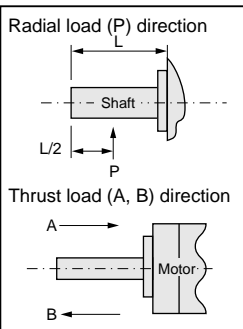
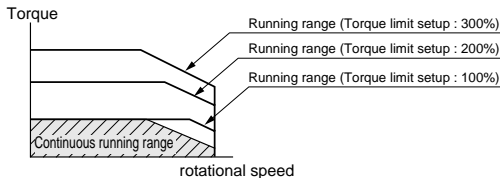

Note) 1. Regenerative brake frequency represents the frequency of the motor's stops from the rated speed with deceleration without load.

- If the load is connected, frequency will be defined as $1/(m+1)$, where m =load moment of inertia/rotor moment of inertia.
 - When the motor speed exceeds the rated speed, regenerative brake frequency is in inverse proportion to the square of (running speed/rated speed).
 - Power supply voltage is AC230V (at 200V of the main voltage).
If the supply voltage fluctuates, frequency is in inverse proportion to the square of (Running supply voltage/230) relative to the value in the table.
 - When regeneration occurs continuously such cases as running speed frequently changes or vertical feeding, consult us or a dealer.
2. If the effective torque is within the rated torque, there is no limit in regenerative brake.
 3. Consult us or a dealer if the load moment of inertia exceeds the specified value.
 4. Specified releasing time is obtained with the use of surge absorber for brake (Z15D151 by Ishizuka Electronic or equivalent).
() represents the actually measured value using a diode (200V, 1A or equivalent)

Motor Specifications and Ratings 200V MGMA 900W to 2.0kW Middle inertia, Medium Capacity

		AC200V					
Motor model		MGMA		092P1 <input type="checkbox"/>	092S1 <input type="checkbox"/>	202P1 <input type="checkbox"/>	202S1 <input type="checkbox"/>
Applicable driver	Model No.	A4 series		MDDDT5540		MFDDTA390	
		A4P series		MDDDT5540P		MFDDTA390P	
	Frame symbol	Frame D		Frame F			
Power supply capacity (kVA)		1.8		3.8			
Rated output (W)		900		2000			
Rated torque (N · m)		8.62		19.1			
Momentary Max. peak torque (N · m)		19.3		44			
Rated current (Arms)		7.6		18.5			
Max. current (Ao-p)		24.0		60.0			
Regenerative brake frequency (times/min) Note)1	Without option	No limit Note)2					
	DV0P4284	No limit Note)2					
	DV0P4285×2	————		No limit Note)2			
Rated rotational speed (r/min)		1000		2000			
Max. rotational speed (r/min)		1000		2000			
Moment of inertia of rotor (x10 ⁻⁴ kg · m ²)	Without brake	11.2		35.5			
	With brake	12.3		41.4			
Recommended moment of inertia ratio of the load and the rotor Note)3		Smaller than 10 times					
Rotary encoder specifications		2500P/r Incremental		17-bit Absolute/ Incremental		2500P/r Incremental	
Resolution per single turn		10000		131072		10000	
Protective enclosure rating		IP65 (except shaft through hole and cable end connector)					
Environment	Ambient temperature	0 to 40°C (free from freezing), Storage : -20 to + 80°C					
	Ambient humidity	85%RH or lower (free from condensing)					
	Installation location	Indoors (no direct sunlight), free from corrosive gas, inflammable gas, oil mist and dust					
	Altitude	1000m or lower					
	Vibration resistance	49m/s ² or less					
Mass (kg), () represents holding brake type		8.5 (10.0)		17.5 (21.0)			

Brake specifications (This brake will be released when it is energized. Do not use this for braking the motor in motion.)		
Static friction torque (N · m)	13.7	24.5
Engaging time (ms)	100	80
Releasing time (ms) Note)4	50 (130)	25 (200)
Exciting current (DC) (A)	0.79	1.30
Releasing voltage	DC2V or more	
Exciting voltage	DC 24 V ± 10%	

Permissible load			
During assembly	Radial load P-direction (N)	980	1666
	Thrust load A-direction (N)	588	784
	Thrust load B-direction (N)	686	980
During operation	Radial load P-direction (N)	686	1176
	Thrust load A-direction (N)	196	490
	Thrust load B-direction (N)	196	490

For motor dimensions, refer to page A4-96 , and for the diver, refer to pages A4-23,24 and A4-46,47.

Model designation MGMA series, 900W to 2.0kW

e.g.)

M G M A 0 9 2 S 1 G

Symbol	Type
MGMA	Middle inertia (900W-2.0kW)

Voltage specifications	
Symbol	Specifications
2	200V

Design order
1 : Standard

Motor structure

Symbol	Shaft		Holding brake		Oil seal	
	Round	Key-way	without	with	without	with
C	●		●			●
D	●			●		●
G		●	●			●
H		●		●		●

Motor rated output	
Symbol	Rated output
09	900W
20	2.0kW

Rotary encoder specifications

Symbol	Format	Pulse counts	Resolution	Wires
P	Incremental	2500P/r	10000	5
S	Absolute/Incremental	17-bit	131072	7

Products are standard stock items or build to order items. See index (page F31).

Torque characteristics at AC200V of power voltage

(Dotted line represents the torque at 10% less supply voltage.)

MGMA092□1□

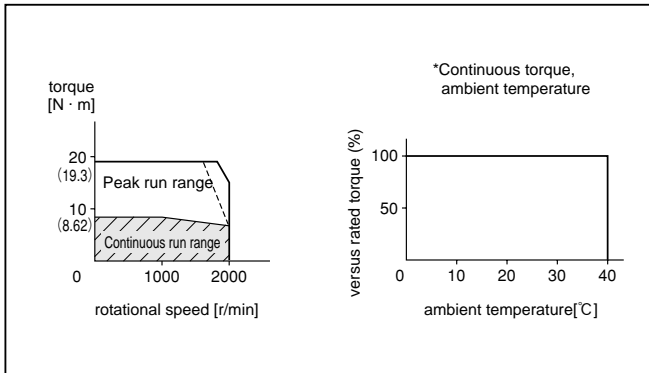

MGMA202□1□

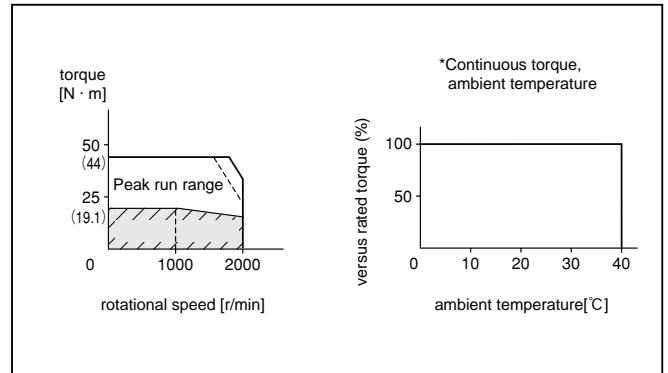

*When you lower the torque limit setup (Pr5E and 5F), running range at high speed might be lowered as well.

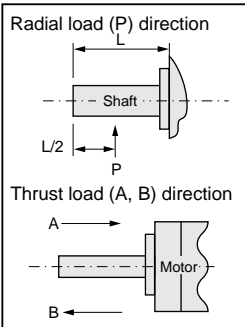
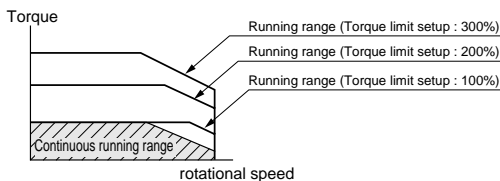

Note) 1. Regenerative brake frequency represents the frequency of the motor's stops from the rated speed with deceleration without load.

- If the load is connected, frequency will be defined as $1/(m+1)$, where m =load moment of inertia/rotor moment of inertia.
 - When the motor speed exceeds the rated speed, regenerative brake frequency is in inverse proportion to the square of (running speed/rated speed).
 - Power supply voltage is AC230V (at 200V of the main voltage).
If the supply voltage fluctuates, frequency is in inverse proportion to the square of (Running supply voltage/230) relative to the value in the table.
 - When regeneration occurs continuously such cases as running speed frequently changes or vertical feeding, consult us or a dealer.
2. If the effective torque is within the rated torque, there is no limit in regenerative brake.
 3. Consult us or a dealer if the load moment of inertia exceeds the specified value.
 4. Specified releasing time is obtained with the use of surge absorber for brake (Z15D151 by Ishizuka Electronic or equivalent).
() represents the actually measured value using a diode (200V, 1A or equivalent)

Motor Specifications and Ratings 200V MGMA 3.0kW to 6.0kW Middle inertia, Medium Capacity

		AC200V						
Motor model		MGMA	302P1□	302S1□	452P1□	452S1□	602P1□	602S1□
Applicable driver	Model No.	A4 series	MFDDTB3A2			MGDDTC3B4		
		A4P series	MFDDTB3A2P			—		
	Frame symbol		Frame F			Frame G		
Power supply capacity (kVA)			5.3		7.5		11	
Rated output (W)			3000		4500		6000	
Rated torque (N · m)			28.4		42.9		57.2	
Momentary Max. peak torque (N · m)			63.7		107		137	
Rated current (Arms)			24		33		47.0	
Max. current (Ao-p)			80.0		118		170.0	
Regenerative brake frequency (times/min) Note)1	Without option	No limit Note)2						
	DV0P4285×2	No limit Note)2			—			
	DV0P4285×4	—			No limit Note)2			
Rated rotational speed (r/min)			1000					
Max. rotational speed (r/min)			2000					
Moment of inertia of rotor (x10 ⁻⁴ kg · m ²)	Without brake		55.7		80.9		99	
	With brake		61.7		86.9		108	
Recommended moment of inertia ratio of the load and the rotor Note)3			Smaller than 10 times					
Rotary encoder specifications			2500P/r Incremental	17-bit Absolute/ Incremental	2500P/r Incremental	17-bit Absolute/ Incremental	2500P/r Incremental	17-bit Absolute/ Incremental
	Resolution per single turn		10000	131072	10000	131072	10000	131072
Protective enclosure rating			IP65 (except shaft through hole and cable end connector)					
Environment	Ambient temperature		0 to 40°C (free from freezing), Storage : -20 to + 80°C					
	Ambient humidity		85%RH or lower (free from condensing)					
	Installation location		Indoors (no direct sunlight), free from corrosive gas, inflammable gas, oil mist and dust					
	Altitude		1000m or lower					
	Vibration resistance		49m/s ² or less			24m/s ² or less		
Mass (kg), () represents holding brake type			25.0 (28.5)		34.0 (39.5)		41.0 (45.0)	

Brake specifications (This brake will be released when it is energized. Do not use this for braking the motor in motion.)	
Static friction torque (N · m)	58.8
Engaging time (ms)	150
Releasing time (ms) Note)4	50 (130)
Exciting current (DC) (A)	1.40
Releasing voltage	DC2V or more
Exciting voltage	DC 24 V ± 10%

Permissible load			
During assembly	Radial load P-direction (N)	2058	2058
	Thrust load A-direction (N)	980	980
	Thrust load B-direction (N)	1176	1176
During operation	Radial load P-direction (N)	1470	1764
	Thrust load A-direction (N)	490	588
	Thrust load B-direction (N)	490	588

For motor dimensions, refer to page A4-97,98, and for the diver, refer to pages A4-24,25 and 47.

Model designation MGMA series, 3.0kW to 6.0kW

e.g.)

M G M A 3 0 2 S 1 G

Symbol	Type
MGMA	Middle inertia (3.0kW-6.0kW)

Voltage specifications	
Symbol	Specifications
2	200V

Design order
1 : Standard

Motor structure

Symbol	Shaft		Holding brake		Oil seal	
	Round	Key-way	without	with	without	with
C	●		●			●
D	●			●		●
G		●	●			●
H		●		●		●

Motor rated output	
Symbol	Rated output
30	3.0kW
45	4.5kW
60	6.0kW

Rotary encoder specifications

Symbol	Format	Pulse counts	Resolution	Wires
P	Incremental	2500P/r	10000	5
S	Absolute/Incremental	17-bit	131072	7

Products are standard stock items or build to order items. See index (page F31).

Torque characteristics at AC200V of power voltage

(Dotted line represents the torque at 10% less supply voltage.)

MGMA302□1□

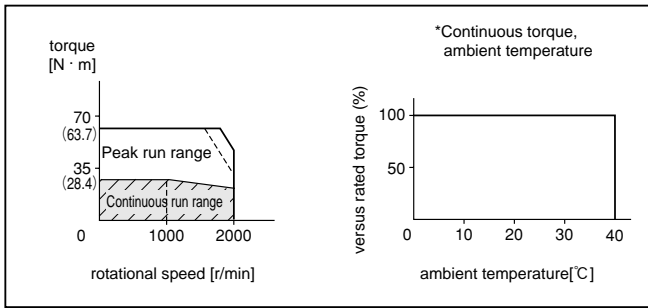

MGMA452□1□

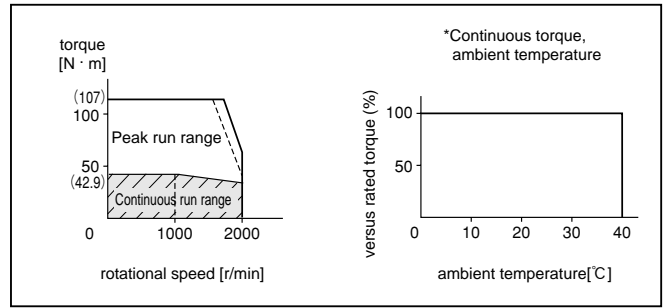

MGMA602□1□

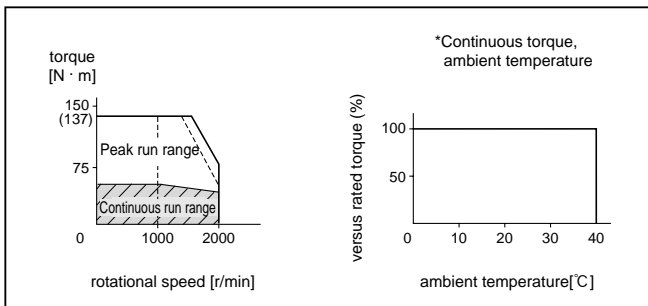

*When you lower the torque limit setup (Pr5E and 5F), running range at high speed might be lowered as well.

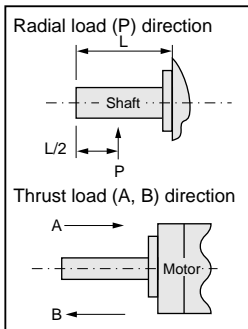
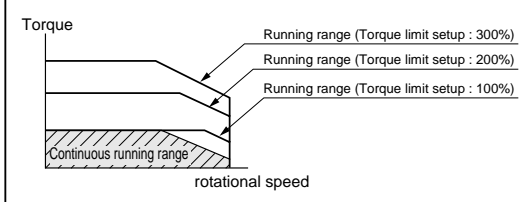

Note) 1. Regenerative brake frequency represents the frequency of the motor's stops from the rated speed with deceleration without load.

- If the load is connected, frequency will be defined as $1/(m+1)$, where m =load moment of inertia/rotor moment of inertia.
 - When the motor speed exceeds the rated speed, regenerative brake frequency is in inverse proportion to the square of (running speed/rated speed).
 - Power supply voltage is AC230V (at 200V of the main voltage).
If the supply voltage fluctuates, frequency is in inverse proportion to the square of (Running supply voltage/230) relative to the value in the table.
 - When regeneration occurs continuously such cases as running speed frequently changes or vertical feeding, consult us or a dealer.
2. If the effective torque is within the rated torque, there is no limit in regenerative brake.
 3. Consult us or a dealer if the load moment of inertia exceeds the specified value.
 4. Specified releasing time is obtained with the use of surge absorber for brake (Z15D151 by Ishizuka Electronic or equivalent).
() represents the actually measured value using a diode (200V, 1A or equivalent)

Motor Specifications and Ratings 200V MFMA

400W to 1.5kW Middle inertia, Medium Capacity

		AC200V							
Motor model		MFMA		042P1 <input type="checkbox"/>	042S1 <input type="checkbox"/>	152P1 <input type="checkbox"/>	152S1 <input type="checkbox"/>		
Applicable driver	Model No.	A4 series			MCDDT3520			MDDDT5540	
		A4P series			MCDDT3520P			MDDDT5540P	
	Frame symbol	Frame C			Frame D				
Power supply capacity (kVA)		1.0			2.3				
Rated output (W)		400			1500				
Rated torque (N · m)		1.9			7.15				
Momentary Max. peak torque (N · m)		5.3			21.5				
Rated current (Arms)		2.8			9.5				
Max. current (Ao-p)		12.0			40.0				
Regenerative brake frequency (times/min) Note)1	Without option	No limit Note)2			100				
	DV0P4283	No limit Note)2			—				
	DV0P4284	—			No limit Note)2				
Rated rotational speed (r/min)		2000			3000				
Max. rotational speed (r/min)		2000			3000				
Moment of inertia of rotor ($\times 10^{-4}$ kg · m ²)	Without brake	2.45			20.1				
	With brake	2.7			21.5				
Recommended moment of inertia ratio of the load and the rotor Note)3		Smaller than 10 times							
Rotary encoder specifications		2500P/r Incremental		17-bit Absolute/ Incremental		2500P/r Incremental		17-bit Absolute/ Incremental	
	Resolution per single turn	10000		131072		10000		131072	
Protective enclosure rating		IP65 (except shaft through hole and cable end connector)							
Environment	Ambient temperature	0 to 40°C (free from freezing), Storage : -20 to + 80°C							
	Ambient humidity	85%RH or lower (free from condensing)							
	Installation location	Indoors (no direct sunlight), free from corrosive gas, inflammable gas, oil mist and dust							
	Altitude	1000m or lower							
	Vibration resistance	49m/s ² or less							
Mass (kg), () represents holding brake type		4.7 (6.7)			11.0 (14.0)				

Brake specifications (This brake will be released when it is energized. Do not use this for braking the motor in motion.)		
Static friction torque (N · m)	4.9	7.8
Engaging time (ms)	80	80
Releasing time (ms) Note)4	70	35
Exciting current (DC) (A)	0.59	0.83
Releasing voltage	DC2V or more	
Exciting voltage	DC 24 V \pm 10%	

Permissible load		
During assembly	Radial load P-direction (N)	980
	Thrust load A-direction (N)	588
	Thrust load B-direction (N)	686
During operation	Radial load P-direction (N)	392
	Thrust load A-direction (N)	147
	Thrust load B-direction (N)	147

For motor dimensions, refer to page A4-99 , and for the diver, refer to pages A4-24 and 47.

Model designation MFMA series, 400W to 1.5kW

e.g.)

M F M A 0 4 2 S 1 G

Symbol	Type
MFMA	Middle inertia (400W-1.5kW)

Voltage specifications	
Symbol	Specifications
2	200V

Design order
1 : Standard

Motor structure

Symbol	Shaft		Holding brake		Oil seal	
	Round	Key-way	without	with	without	with
C	●		●			●
D	●			●		●
G		●	●			●
H		●		●		●

Motor rated output	
Symbol	Rated output
04	400W
15	1.5kW

Rotary encoder specifications

Symbol	Format	Pulse counts	Resolution	Wires
P	Incremental	2500P/r	10000	5
S	Absolute/Incremental	17-bit	131072	7

Products are standard stock items or build to order items. See index (page F31).

Torque characteristics at AC200V of power voltage

(Dotted line represents the torque at 10% less supply voltage.)

MFMA042□1□

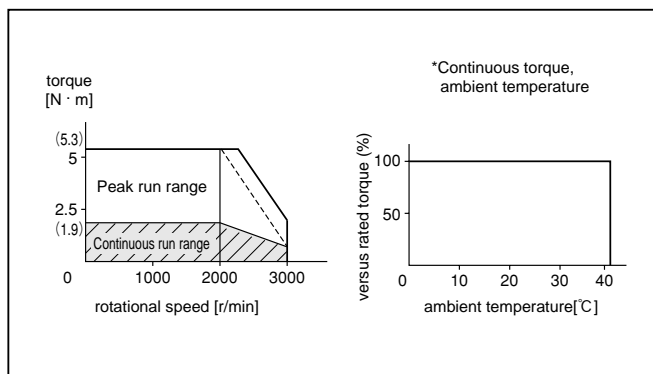

MFMA152□1□

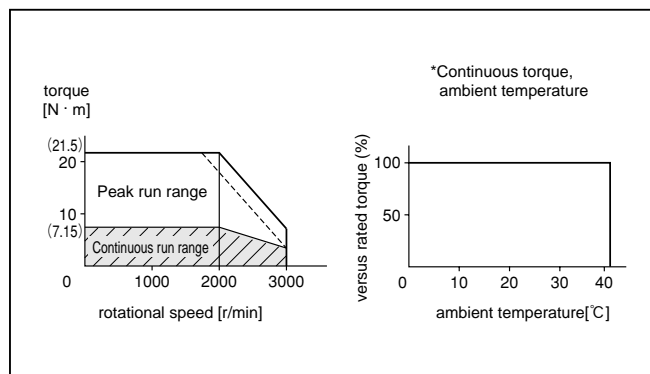

*When you lower the torque limit setup (Pr5E and 5F), running range at high speed might be lowered as well.

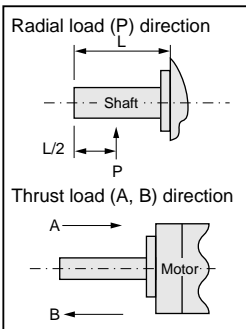
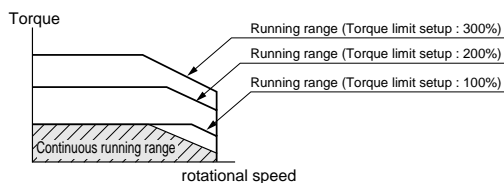

Note) 1. Regenerative brake frequency represents the frequency of the motor's stops from the rated speed with deceleration without load.

- If the load is connected, frequency will be defined as $1/(m+1)$, where m =load moment of inertia/rotor moment of inertia.
 - When the motor speed exceeds the rated speed, regenerative brake frequency is in inverse proportion to the square of (running speed/rated speed).
 - Power supply voltage is AC230V (at 200V of the main voltage).
If the supply voltage fluctuates, frequency is in inverse proportion to the square of (Running supply voltage/230) relative to the value in the table.
 - When regeneration occurs continuously such cases as running speed frequently changes or vertical feeding, consult us or a dealer.
2. If the effective torque is within the rated torque, there is no limit in generative brake.
 3. Consult us or a dealer if the load moment of inertia exceeds the specified value.
 4. Specified releasing time is obtained with the use of surge absorber for brake (Z15D151 by Ishizuka Electronic or equivalent).
() represents the actually measured value using a diode (200V, 1A or equivalent)

Motor Specifications and Ratings 200V MFMA

2.5kW to 4.5kW Middle inertia, Medium Capacity

			AC200V						
Motor model			MFMA		252P1□	252S1□	452P1□	452S1□	
Applicable driver	Model No.	A4 series	MEDDT7364			MFDDTB3A2			
		A4P series	MEDDT7364P			MFDDTB3A2P			
	Frame symbol		Frame E			Frame F			
Power supply capacity (kVA)			3.8			6.8			
Rated output (W)			2500			4500			
Rated torque (N · m)			11.8			21.5			
Momentary Max. peak torque (N · m)			30.4			54.9			
Rated current (Arms)			13.4			23.5			
Max. current (Ao-p)			57.0			100.0			
Regenerative brake frequency (times/min) Note)1	Without option		75			67			
	DV0P4285×2		No limit Note)2			375			
Rated rotational speed (r/min)			2000						
Max. rotational speed (r/min)			3000						
Moment of inertia of rotor (x10 ⁻⁴ kg · m ²)	Without brake		41.3			72.3			
	With brake		45.3			78.5			
Recommended moment of inertia ratio of the load and the rotor Note)3			Smaller than 10 times						
Rotary encoder specifications			2500P/r Incremental		17-bit Absolute/ Incremental		2500P/r Incremental		17-bit Absolute/ Incremental
			Resolution per single turn		10000		131072		10000
Protective enclosure rating			IP65 (except shaft through hole and cable end connector)						
Environment	Ambient temperature		0 to 40°C (free from freezing), Storage : -20 to + 80°C						
	Ambient humidity		85%RH or lower (free from condensing)						
	Installation location		Indoors (no direct sunlight), free from corrosive gas, inflammable gas, oil mist and dust						
	Altitude		1000m or lower						
	Vibration resistance		49m/s ² or less						
Mass (kg), () represents holding brake type			14.8 (17.5)			19.9 (24.3)			

Brake specifications (This brake will be released when it is energized. Do not use this for braking the motor in motion.)			
Static friction torque (N · m)		21.6	31.4
Engaging time (ms)		150	150
Releasing time (ms) Note)4		100 (450)	100 (450)
Exciting current (DC) (A)		0.75	0.75
Releasing voltage		DC2V or more	
Exciting voltage		DC 24 V ± 10%	

Permissible load		
During assembly	Radial load P-direction (N)	1862
	Thrust load A-direction (N)	686
	Thrust load B-direction (N)	686
During operation	Radial load P-direction (N)	784
	Thrust load A-direction (N)	294
	Thrust load B-direction (N)	294

For motor dimensions, refer to page A4-100 , and for the diver, refer to pages A4-24 and 47.

Model designation MFMA series, 2.5kW to 4.5kW

e.g.)

M F M A 2 5 2 S 1 G

Symbol	Type
MFMA	Middle inertia (2.5kW-4.5kW)

Voltage specifications	
Symbol	Specifications
2	200V

Design order
1 : Standard

Motor structure

Symbol	Shaft		Holding brake		Oil seal	
	Round	Key-way	without	with	without	with
C	●		●			●
D	●			●		●
G		●	●			●
H		●		●		●

Products are standard stock items or build to order items. See index (page F31).

Motor rated output	
Symbol	Rated output
25	2.5kW
45	4.5kW

Rotary encoder specifications				
Symbol	Format	Pulse counts	Resolution	Wires
P	Incremental	2500P/r	10000	5
S	Absolute/Incremental	17-bit	131072	7

Torque characteristics at AC200V of power voltage

(Dotted line represents the torque at 10% less supply voltage.)

MFMA252□1□

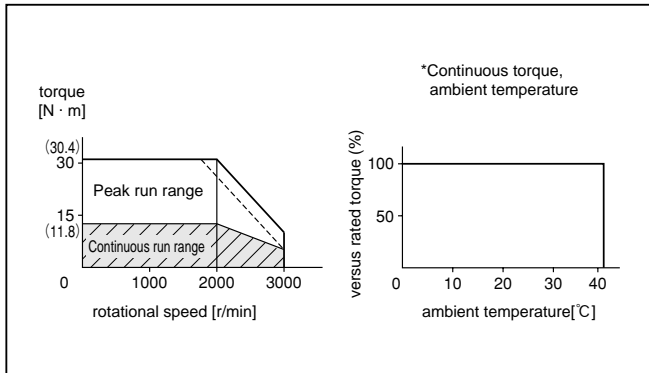

MFMA452□1□

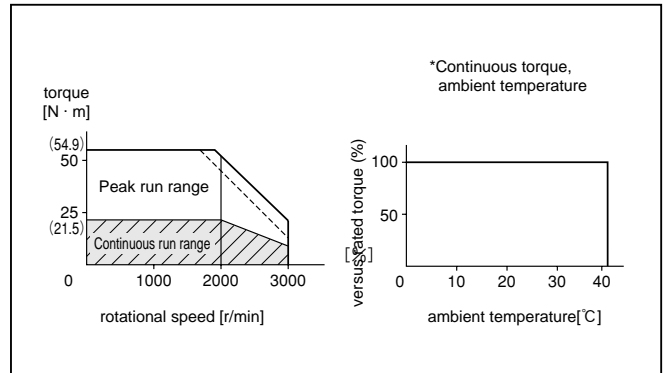

*When you lower the torque limit setup (Pr5E and 5F), running range at high speed might be lowered as well.

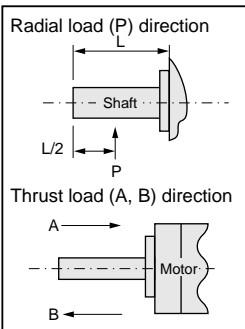
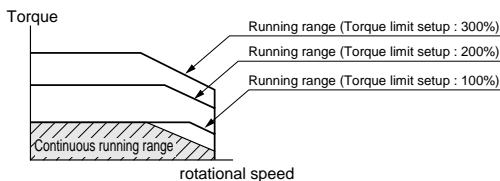

Note) 1. Regenerative brake frequency represents the frequency of the motor's stops from the rated speed with deceleration without load.

- If the load is connected, frequency will be defined as $1/(m+1)$, where m =load moment of inertia/rotor moment of inertia.
 - When the motor speed exceeds the rated speed, regenerative brake frequency is in inverse proportion to the square of (running speed/rated speed).
 - Power supply voltage is AC230V (at 200V of the main voltage).
If the supply voltage fluctuates, frequency is in inverse proportion to the square of (Running supply voltage/230) relative to the value in the table.
 - When regeneration occurs continuously such cases as running speed frequently changes or vertical feeding, consult us or a dealer.
2. If the effective torque is within the rated torque, there is no limit in generative brake.
 3. Consult us or a dealer if the load moment of inertia exceeds the specified value.
 4. Specified releasing time is obtained with the use of surge absorber for brake (Z15D151 by Ishizuka Electronic or equivalent).
() represents the actually measured value using a diode (200V, 1A or equivalent)

Motor Specifications and Ratings 200V MHMA

500W to 1.5kW High inertia, Medium Capacity

		AC200V							
Motor model		MHMA		052P1□	052S1□	102P1□	102S1□	152P1□	152S1□
Applicable driver	Model No.	A4 series	MCDDT3520		MDDDT3530		MDDDT5540		
		A4P series	MCDDT3520P		MDDDT3530P		MDDDT5540P		
	Frame symbol		Frame C			Frame D			
Power supply capacity (kVA)		1.0			1.8		2.3		
Rated output (W)		500			1000		1500		
Rated torque (N · m)		2.38			4.8		7.15		
Momentary Max. peak torque (N · m)		6.0			14.4		21.5		
Rated current (Arms)		3.2			5.6		9.4		
Max. current (Ao-p)		11.5			24.0		40.0		
Regenerative brake frequency (times/min) Note)1	Without option	No limit Note)2		33		25			
	DV0P4283	No limit Note)2		—————					
	DV0P4284	—————		No limit Note)2					
Rated rotational speed (r/min)		2000							
Max. rotational speed (r/min)		3000							
Moment of inertia of rotor ($\times 10^{-4}$ kg · m ²)	Without brake	14.0			26.0		42.9		
	With brake	15.2			27.2		44.1		
Recommended moment of inertia ratio of the load and the rotor Note)3		Smaller than 5 times							
Rotary encoder specifications		2500P/r Incremental	17-bit Absolute/ Incremental	2500P/r Incremental	17-bit Absolute/ Incremental	2500P/r Incremental	17-bit Absolute/ Incremental	2500P/r Incremental	17-bit Absolute/ Incremental
Resolution per single turn		10000	131072	10000	131072	10000	131072	10000	131072
Protective enclosure rating		IP65 (except shaft through hole and cable end connector)							
Environment	Ambient temperature	0 to 40°C (free from freezing), Storage : -20 to + 80°C							
	Ambient humidity	85%RH or lower (free from condensing)							
	Installation location	Indoors (no direct sunlight), free from corrosive gas, inflammable gas, oil mist and dust							
	Altitude	1000m or lower							
	Vibration resistance	49m/s ² or less							
Mass (kg), () represents holding brake type		5.3 (6.9)			8.9 (9.5)		10.0 (11.6)		

Brake specifications (This brake will be released when it is energized. Do not use this for braking the motor in motion.)			
Static friction torque (N · m)	4.9		13.7
Engaging time (ms)	80		100
Releasing time (ms) Note)4	70 (200)		50 (130)
Exciting current (DC) (A)	0.59		0.79
Releasing voltage	DC2V or more		
Exciting voltage	DC 24 V \pm 10%		

Permissible load			
During assembly	Radial load P-direction (N)	980	
	Thrust load A-direction (N)	588	
	Thrust load B-direction (N)	686	
During operation	Radial load P-direction (N)	490	
	Thrust load A-direction (N)	196	
	Thrust load B-direction (N)	196	

For motor dimensions, refer to page A4-101 , and for the diver, refer to pages A4-23 and 46.

Model designation MHMA series, 500W to 1.5kW

e.g.)

M H M A 0 5 2 S 1 G

Symbol	Type
MHMA	High inertia (500W-1.5kW)

Voltage specifications	
Symbol	Specifications
2	200V

Design order
1 : Standard

Motor structure

Symbol	Shaft		Holding brake		Oil seal	
	Round	Key-way	without	with	without	with
C	●		●			●
D	●			●		●
G		●	●			●
H		●		●		●

Motor rated output	
Symbol	Rated output
05	500kW
10	1.0kW
15	1.5kW

Rotary encoder specifications

Symbol	Format	Pulse counts	Resolution	Wires
P	Incremental	2500P/r	10000	5
S	Absolute/Incremental	17-bit	131072	7

Products are standard stock items or build to order items. See index (page F31).

Torque characteristics at AC200V of power voltage

(Dotted line represents the torque at 10% less supply voltage.)

MHMA052□1□

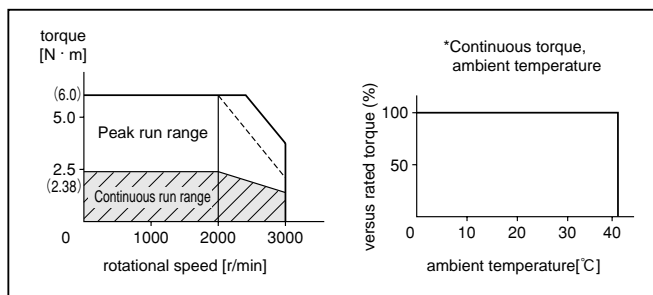

MHMA102□1□

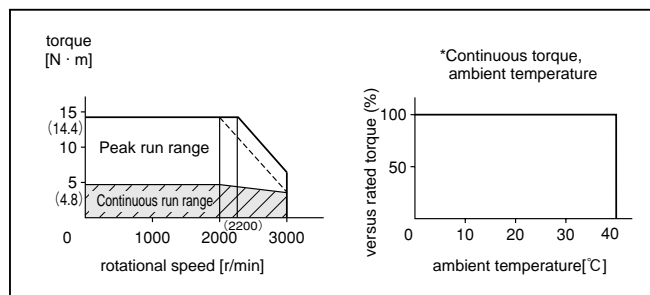

MHMA152□1□

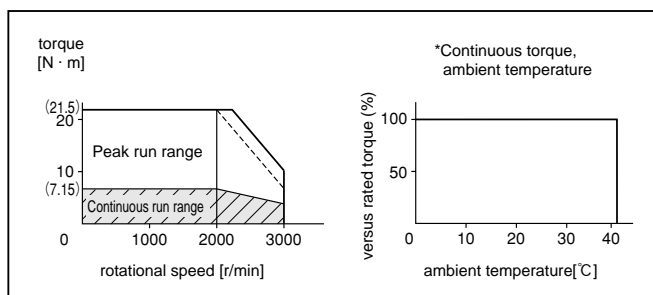

*When you lower the torque limit setup (Pr5E and 5F), running range at high speed might be lowered as well.

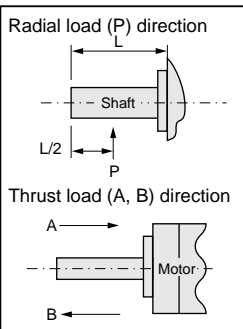
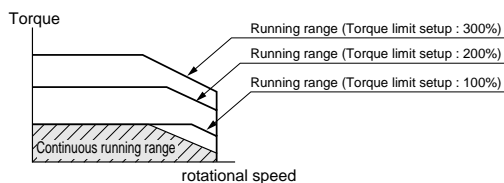

Note) 1. Regenerative brake frequency represents the frequency of the motor's stops from the rated speed with deceleration without load.

- If the load is connected, frequency will be defined as $1/(m+1)$, where m =load moment of inertia/rotor moment of inertia.
 - When the motor speed exceeds the rated speed, regenerative brake frequency is in inverse proportion to the square of (running speed/rated speed).
 - Power supply voltage is AC230V (at 200V of the main voltage).
If the supply voltage fluctuates, frequency is in inverse proportion to the square of (Running supply voltage/230) relative to the value in the table.
 - When regeneration occurs continuously such cases as running speed frequently changes or vertical feeding, consult us or a dealer.
2. If the effective torque is within the rated torque, there is no limit in regenerative brake.
 3. Consult us or a dealer if the load moment of inertia exceeds the specified value.
 4. Specified releasing time is obtained with the use of surge absorber for brake (Z15D151 by Ishizuka Electronic or equivalent).
() represents the actually measured value using a diode (200V, 1A or equivalent)

Motor Specifications and Ratings 200V MHMA 2.0kW to 5.0kW High inertia, Medium Capacity

		AC200V									
Motor model		MHMA		202P1 <input type="checkbox"/>	202S1 <input type="checkbox"/>	302P1 <input type="checkbox"/>	302S1 <input type="checkbox"/>	402P1 <input type="checkbox"/>	402S1 <input type="checkbox"/>	502P1 <input type="checkbox"/>	502S1 <input type="checkbox"/>
Applicable driver	Model No.	A4 series	MEDDT7364		MFDDTA390		MFDDTB3A2				
		A4P series	MEDDT7364P		MFDDTA390P		MFDDTB3A2P				
	Frame symbol	Frame E			Frame F						
Power supply capacity (kVA)		3.3		4.5		6.0		7.5			
Rated output (W)		2000		3000		4000		5000			
Rated torque (N · m)		9.54		14.3		18.8		23.8			
Momentary Max. peak torque (N · m)		28.5		42.9		56.4		71.4			
Rated current (Arms)		12.3		17.8		23.4		28.0			
Max. current (Ao-p)		52.0		76.0		100.0		120.0			
Regenerative brake frequency (times/min) Note)1	Without option	38		43		32		20			
	DV0P4285×2	No limit		Note)2		200		150			
Rated rotational speed (r/min)		2000									
Max. rotational speed (r/min)		3000									
Moment of inertia of rotor (×10 ⁻⁴ kg · m ²)	Without brake	62.0		94.1		120.0		170.0			
	With brake	67.9		100.0		126.0		176.0			
Recommended moment of inertia ratio of the load and the rotor Note)3		Smaller than 5 times									
Rotary encoder specifications		2500P/r Incremental	17-bit Absolute/Incremental	2500P/r Incremental	17-bit Absolute/Incremental	2500P/r Incremental	17-bit Absolute/Incremental	2500P/r Incremental	17-bit Absolute/Incremental	2500P/r Incremental	17-bit Absolute/Incremental
		Resolution per single turn	10000	131072	10000	131072	10000	131072	10000	131072	10000
Protective enclosure rating		IP65 (except shaft through hole and cable end connector)									
Environment	Ambient temperature	0 to 40°C (free from freezing), Storage : -20 to + 80°C									
	Ambient humidity	85%RH or lower (free from condensing)									
	Installation location	Indoors (no direct sunlight), free from corrosive gas, inflammable gas, oil mist and dust									
	Altitude	1000m or lower									
	Vibration resistance	49m/s ² or less									
Mass (kg), () represents holding brake type		16.0 (19.5)		18.2 (21.7)		22.0 (25.5)		26.7 (30.2)			

Brake specifications (This brake will be released when it is energized. Do not use this for braking the motor in motion.)	
Static friction torque (N · m)	24.5
Engaging time (ms)	80
Releasing time (ms) Note)4	25 (200)
Exciting current (DC) (A)	1.30
Releasing voltage	DC2V or more
Exciting voltage	DC 24 V ± 10%

Permissible load		
During assembly	Radial load P-direction (N)	1666
	Thrust load A-direction (N)	784
	Thrust load B-direction (N)	980
During operation	Radial load P-direction (N)	784
	Thrust load A-direction (N)	343
	Thrust load B-direction (N)	343

For motor dimensions, refer to page A4-102 , and for the diver, refer to pages A4-24 and 47.

Model designation MHMA series, 2.0kW to 5.0kW

e.g.)

M H M A 2 0 2 S 1 G

Symbol	Type
MHMA	High inertia (2.0kW-5.0kW)

Voltage specifications	
Symbol	Specifications
2	200V

Design order
1 : Standard

Motor structure

Symbol	Shaft		Holding brake		Oil seal	
	Round	Key-way	without	with	without	with
C	●		●			●
D	●			●		●
G		●	●			●
H		●		●		●

Motor rated output	
Symbol	Rated output
20	2.0kW
30	3.0kW
40	4.0kW
50	5.0kW

Rotary encoder specifications

Symbol	Format	Pulse counts	Resolution	Wires
P	Incremental	2500P/r	10000	5
S	Absolute/Incremental	17-bit	131072	7

Products are standard stock items or build to order items. See index (page F31).

Torque characteristics at AC200V of power voltage

(Dotted line represents the torque at 10% less supply voltage.)

MHMA202□1□

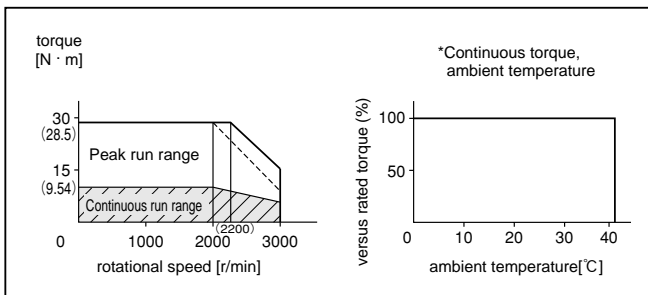

MHMA302□1□

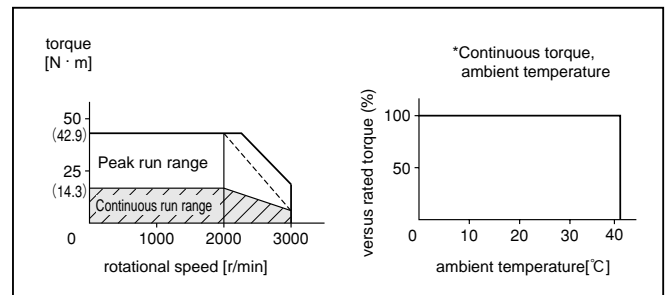

MHMA402□1□

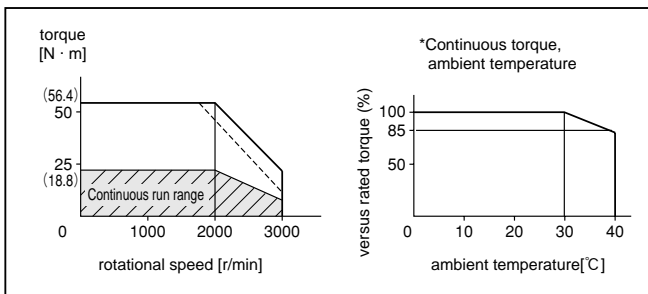

MHMA502□1□

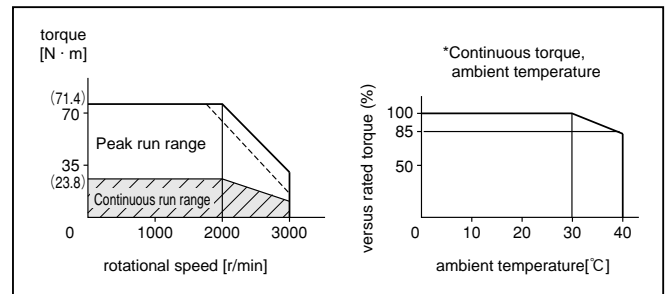

*When you lower the torque limit setup (Pr5E and 5F), running range at high speed might be lowered as well.

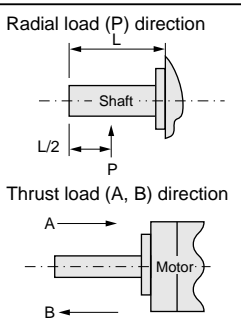
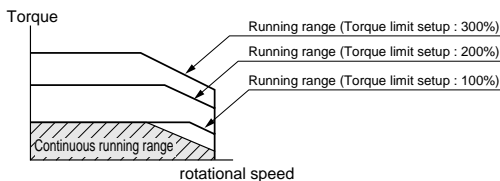

Note) 1. Regenerative brake frequency represents the frequency of the motor's stops from the rated speed with deceleration without load.

- If the load is connected, frequency will be defined as $1/(m+1)$, where m =load moment of inertia/rotor moment of inertia.
 - When the motor speed exceeds the rated speed, regenerative brake frequency is in inverse proportion to the square of (running speed/rated speed).
 - Power supply voltage is AC230V (at 200V of the main voltage).
 If the supply voltage fluctuates, frequency is in inverse proportion to the square of (Running supply voltage/230) relative to the value in the table.
 - When regeneration occurs continuously such cases as running speed frequently changes or vertical feeding, consult us or a dealer.
2. If the effective torque is within the rated torque, there is no limit in regenerative brake.
 3. Consult us or a dealer if the load moment of inertia exceeds the specified value.
 4. Specified releasing time is obtained with the use of surge absorber for brake (Z15D151 by Ishizuka Electronic or equivalent).
 () represents the actually measured value using a diode (200V, 1A or equivalent)

Motor Specifications and Ratings 200V MHMA

7.5kW High inertia, Large Capacity

		AC200V	
Motor model		MHMA	
		752P1 <input type="checkbox"/>	752S1 <input type="checkbox"/>
Applicable driver	Model No.	MGDDTC3B4	
	A4 series A4P series	—————	
	Frame symbol	Frame G	
Power supply capacity (kVA)		11	
Rated output (W)		7500	
Rated torque (N · m)		48	
Momentary Max. peak torque (N · m)		119	
Rated current (Arms)		46.6	
Max. current (Ao-p)		165.0	
Regenerative brake frequency (times/min) Note)1	Without option	0	
	DV0P4285×4	No limit Note)2	
Rated rotational speed (r/min)		1500	
Max. rotational speed (r/min)		3000	
Moment of inertia of rotor (x10 ⁻⁴ kg · m ²)	Without brake	282	
	With brake	288	
Recommended moment of inertia ratio of the load and the rotor Note)3		Smaller than 5 times	
Rotary encoder specifications		2500P/r Incremental	17-bit Absolute/ Incremental
		Resolution per single turn 10000	131072
Protective enclosure rating		IP65 (except shaft through hole and cable end connector)	
Environment	Ambient temperature	0 to 40°C (free from freezing), Storage : -20 to + 80°C	
	Ambient humidity	85%RH or lower (free from condensing)	
	Installation location	Indoors (no direct sunlight), free from corrosive gas, inflammable gas, oil mist and dust	
	Altitude	1000m or lower	
	Vibration resistance	24m/s ² or less	
Mass (kg), () represents holding brake type		43.5 (47.5)	

Brake specifications (This brake will be released when it is energized. Do not use this for braking the motor in motion.)	
Static friction torque (N · m)	58.5
Engaging time (ms)	150
Releasing time (ms) Note)4	50 (130)
Exciting current (DC) (A)	1.30
Releasing voltage	DC2V or more
Exciting voltage	DC 24 V ± 10%

Permissible load		
During assembly	Radial load P-direction (N)	2058
	Thrust load A-direction (N)	980
	Thrust load B-direction (N)	1176
During operation	Radial load P-direction (N)	1176
	Thrust load A-direction (N)	490
	Thrust load B-direction (N)	490

For motor dimensions, refer to page A4-103 , and for the diver, refer to pages A4-25.

Model designation MHMA series, 7.5kW

e.g.)

M H M A 7 5 2 S 1 G

Symbol	Type
MHMA	High inertia (7.5kW)

Voltage specifications	
Symbol	Specifications
2	200V

Design order
1 : Standard

Motor structure

Symbol	Shaft		Holding brake		Oil seal	
	Round	Key-way	without	with	without	with
C	●		●			●
D	●			●		●
G		●	●			●
H		●		●		●

Motor rated output	
Symbol	Rated output
75	7.5kW

Rotary encoder specifications

Symbol	Format	Pulse counts	Resolution	Wires
P	Incremental	2500P/r	10000	5
S	Absolute/Incremental	17-bit	131072	7

Products are standard stock items or build to order items. See index (page F31).

Torque characteristics at AC200V of power voltage

(Dotted line represents the torque at 10% less supply voltage.)

MHMA752□1□

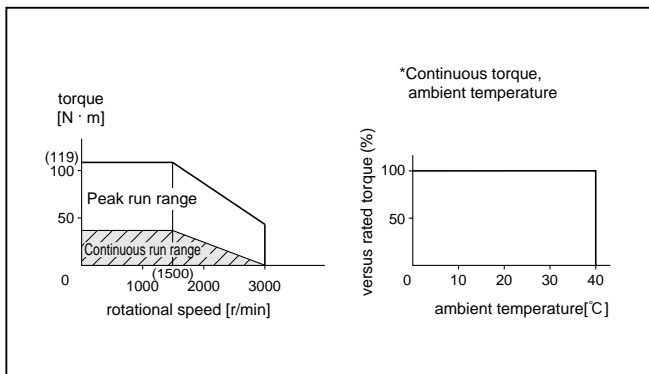

*When you lower the torque limit setup (Pr5E and 5F), running range at high speed might be lowered as well.

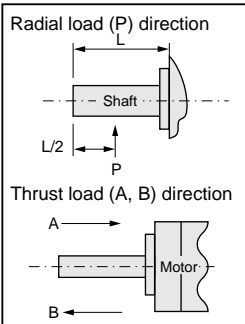
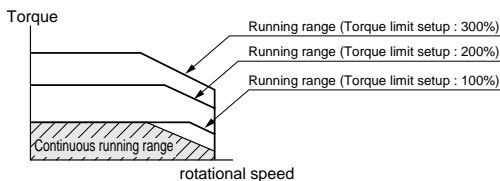

Note) 1. Regenerative brake frequency represents the frequency of the motor's stops from the rated speed with deceleration without load.

- If the load is connected, frequency will be defined as $1/(m+1)$, where m =load moment of inertia/rotor moment of inertia.
 - When the motor speed exceeds the rated speed, regenerative brake frequency is in inverse proportion to the square of (running speed/rated speed).
 - Power supply voltage is AC230V (at 200V of the main voltage).
If the supply voltage fluctuates, frequency is in inverse proportion to the square of (Running supply voltage/230) relative to the value in the table.
 - When regeneration occurs continuously such cases as running speed frequently changes or vertical feeding, consult us or a dealer.
2. If the effective torque is within the rated torque, there is no limit in regenerative brake.
 3. Consult us or a dealer if the load moment of inertia exceeds the specified value.
 4. Specified releasing time is obtained with the use of surge absorber for brake (Z15D151 by Ishizuka Electronic or equivalent).
() represents the actually measured value using a diode (200V, 1A or equivalent)

Motor Dimensions

MAMA 100W - 750W

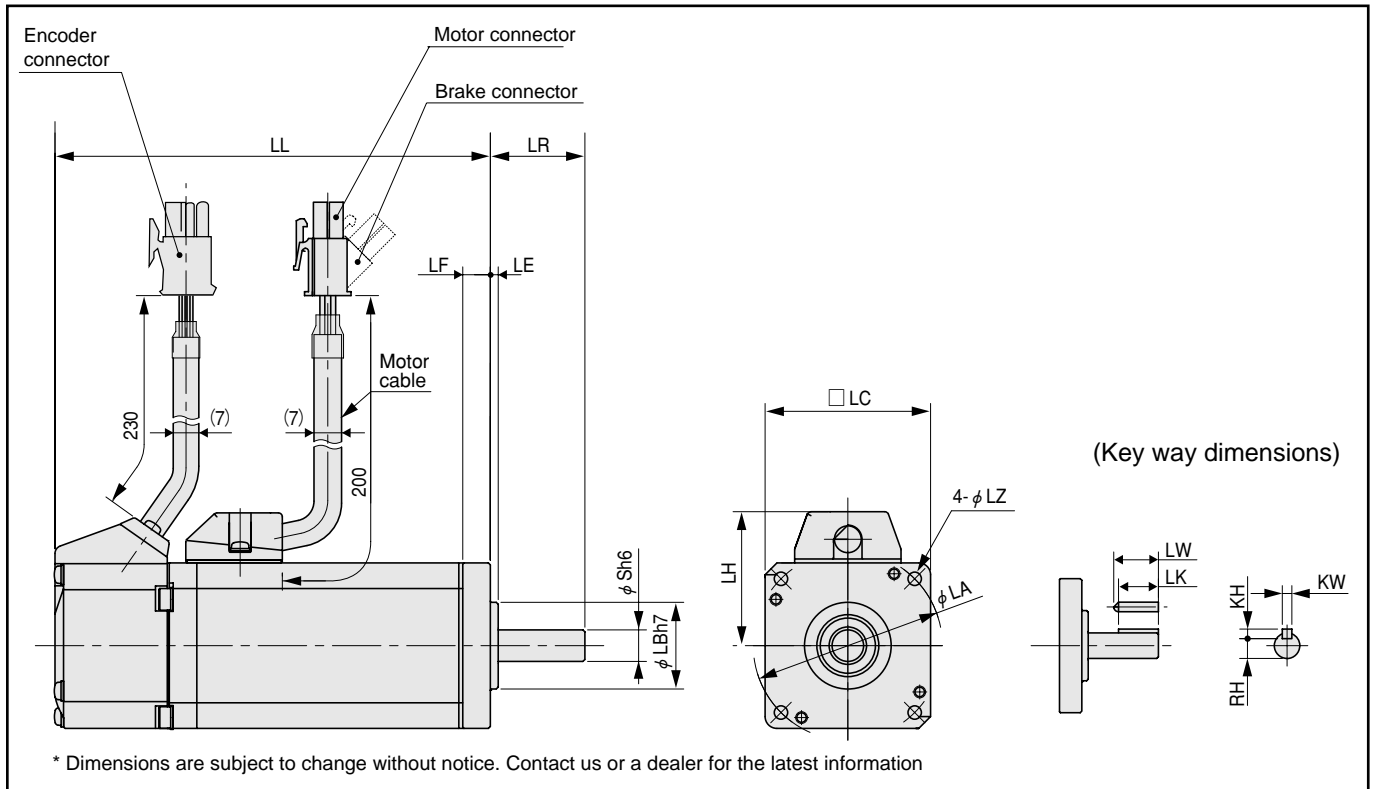

MAMA series (Ultra low inertia)											
Motor output		100W		200W		400W		750W			
Motor model		MAMA		012P1□	012S1□	022P1□	022S1□	042P1□	042S1□	082P1□	082S1□
Rotary encoder specifications		2500P/r Incremental	17-bit Absolute/ Incremental	2500P/r Incremental	17-bit Absolute/ Incremental	2500P/r Incremental	17-bit Absolute/ Incremental	2500P/r Incremental	17-bit Absolute/ Incremental	2500P/r Incremental	17-bit Absolute/ Incremental
LL	Without brake	110.5	127	111	126	139	154	160	175		
	With brake	138	154.5	139	154	167	182	192.5	207.5		
LR		24		30		30		35			
S		8		11		14		19			
LA		48		70		70		90			
LB		22		50		50		70			
LC		42		60		60		80			
LD		—		—		—		—			
LE		2		3		3		3			
LF		7		7		7		8			
LG		—		—		—		—			
LH		34		43		43		53			
LZ		3.4		4.5		4.5		6			
Key way	LW	14		20		25		25			
	LK	12.5		18		22.5		22			
	KW	3h9		4h9		5h9		6h9			
	KH	3		4		5		6			
	RH	6.2		8.5		11		15.5			
Mass (kg)	Without brake	0.65	0.71	1.1	1.2	1.5	1.6	3.3	3.4		
	With brake	0.85	0.91	1.5	1.6	1.9	2.0	4.0	4.1		
Connector/Plug specifications		refer to page A4-120									

* Cautions : Reduce the moment of inertia ratio if high speed response operation is required.

Read the Instruction Manual carefully and understand all precautions and remarks before using the products.

Motor Dimensions

MSMD 50W - 100W

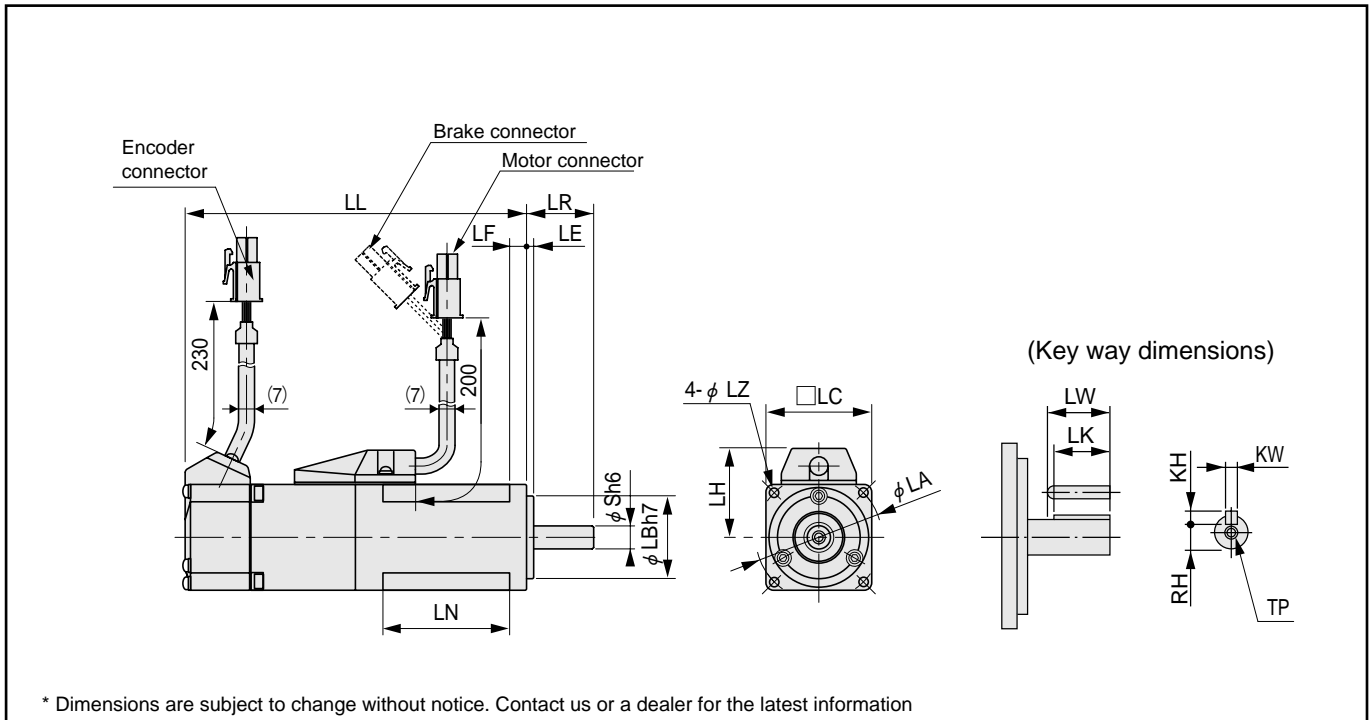

		MSMD series (Low inertia)			
Motor output		50W		100W	
Motor model		5A□P1□	5A□S1□	01□P1□	01□S1□
Rotary encoder specifications		2500P/r Incremental	17-bit Absolute/ Incremental	2500P/r Incremental	17-bit Absolute/ Incremental
LL	Without brake	72		92	
	With brake	102		122	
LR		25		25	
S		8		8	
LA		45		45	
LB		30		30	
LC		38		38	
LD		—		—	
LE		3		3	
LF		6		6	
LG		—		—	
LH		32		32	
LN		26.5		46.5	
LZ		3.4		3.4	
Key way	LW	14		14	
	LK	12.5		12.5	
	KW	3h9		3h9	
	KH	3		3	
	RH	6.2		6.2	
	TP	M3 x 6 (depth)		M3 x 6 (depth)	
Mass (kg)	Without brake	0.32		0.47	
	With brake	0.53		0.68	
Connector/Plug specifications		refer to page A4-120			

* Cautions : Reduce the moment of inertia ratio if high speed response operation is required.

Read the Instruction Manual carefully and understand all precautions and remarks before using the products.

Motor Dimensions

MSMD 200W - 750W

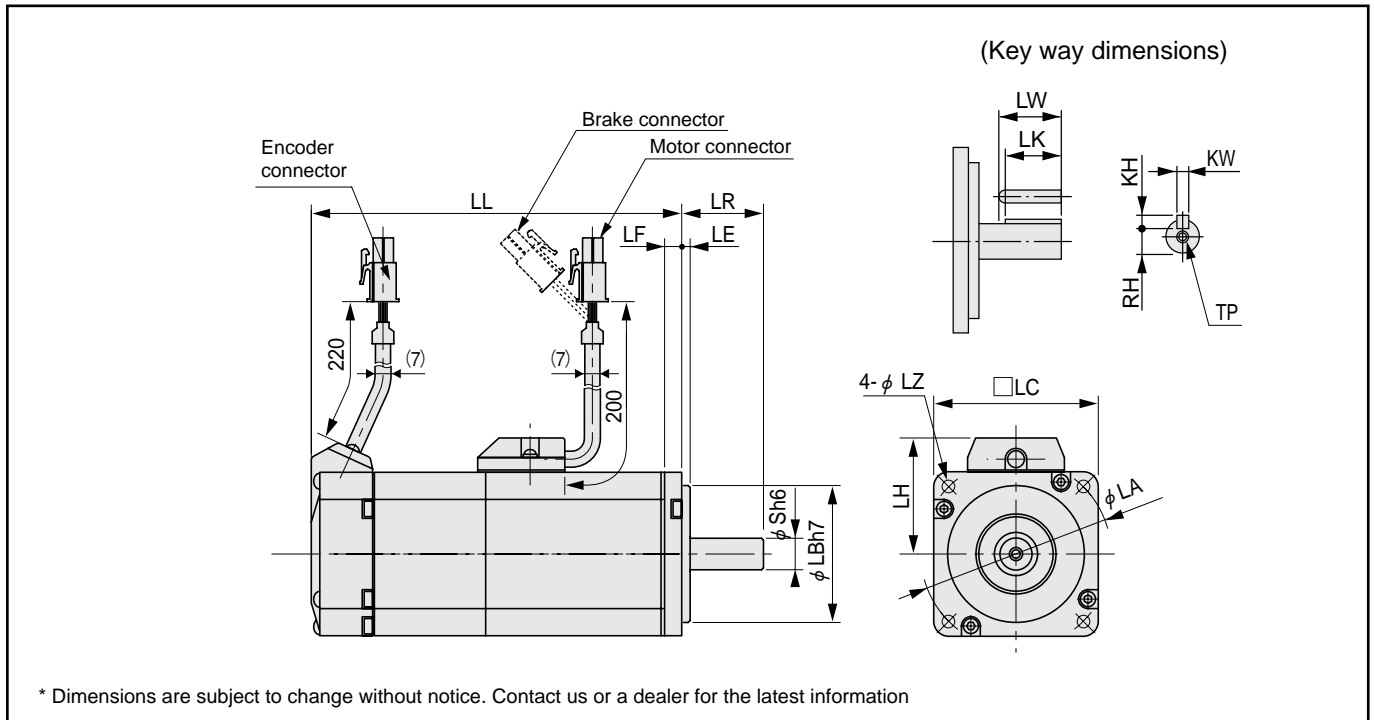

		MSMD series (Low inertia)					
Motor output		200W		400W		750W	
Motor model		02□P1□	02□S1□	04□P1□	04□S1□	08□P1□	08□S1□
Rotary encoder specifications		2500P/r Incremental	17-bit Absolute/ Incremental	2500P/r Incremental	17-bit Absolute/ Incremental	2500P/r Incremental	17-bit Absolute/ Incremental
LL	Without brake	79		98.5		112	
	With brake	115.5		135		149	
LR		30		30		35	
S		11		14		19	
LA		70		70		90	
LB		50		50		70	
LC		60		60		80	
LD		—		—		—	
LE		3		3		3	
LF		6.5		6.5		8	
LG		—		—		—	
LH		43		43		53	
LN		—		—		—	
LZ		4.5		4.5		6	
Key way	LW	20		25		25	
	LK	18		22.5		22	
	KW	4h9		5h9		6h9	
	KH	4		5		6	
	RH	8.5		11		15.5	
	TP	M4 x 8 (depth)		M5 x 10 (depth)		M5 x 10 (depth)	
Mass (kg)	Without brake	0.82		1.2		2.3	
	With brake	1.3		1.7		3.1	
Connector/Plug specifications		refer to page A4-120					

* Cautions : Reduce the moment of inertia ratio if high speed response operation is required.

Read the Instruction Manual carefully and understand all precautions and remarks before using the products.

Motor Dimensions

MQMA 100W - 400W

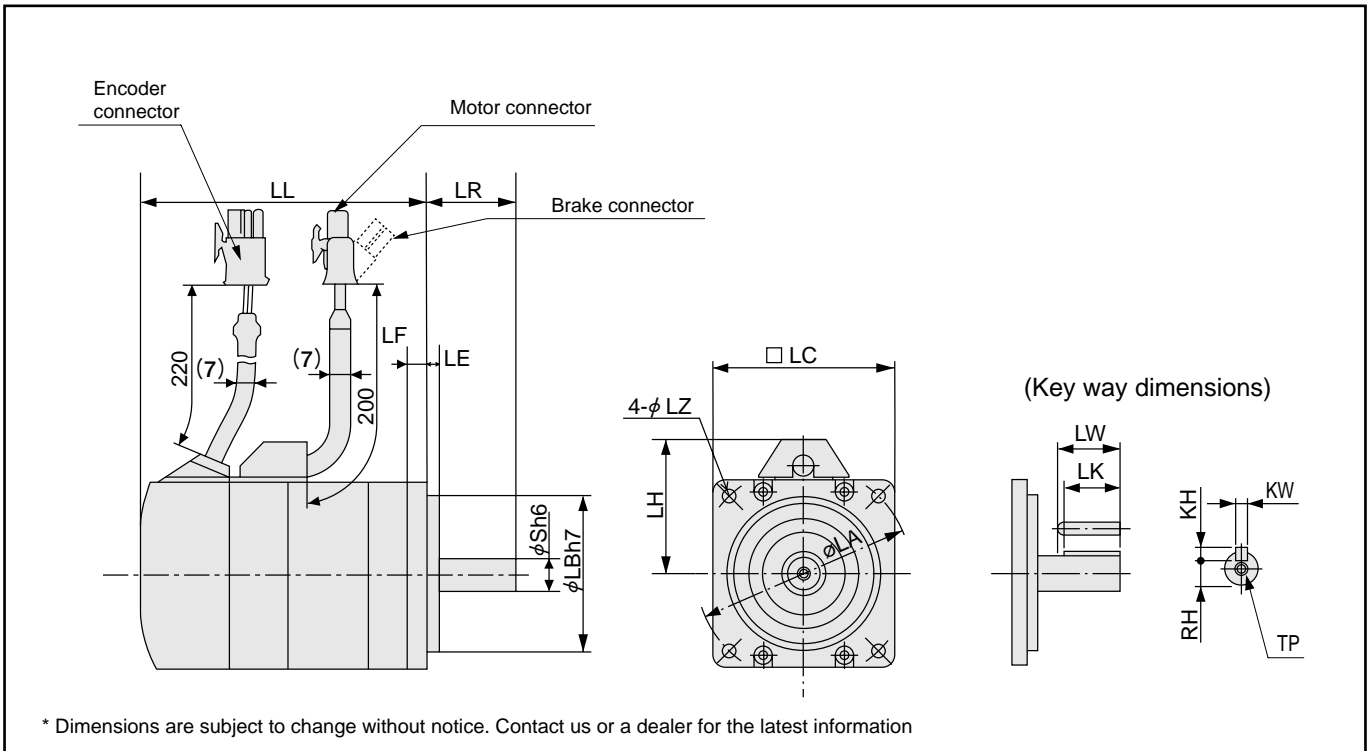

MQMA series (Low inertia)

Motor output		100W		200W		400W	
Motor model	MQMA	01□P1□	01□S1□	02□P1□	02□S1□	04□P1□	04□S1□
Rotary encoder specifications		2500P/r Incremental	17-bit Absolute/ Incremental	2500P/r Incremental	17-bit Absolute/ Incremental	2500P/r Incremental	17-bit Absolute/ Incremental
LL	Without brake	60	87	67	94	82	109
	With brake	84	111	99.5	126.5	114.5	141.5
LR		25		30		30	
S		8		11		14	
LA		70		90		90	
LB		50		70		70	
LC		60		80		80	
LD		—		—		—	
LE		3		5		5	
LF		7		8		8	
LG		—		—		—	
LH		43		53		53	
LZ		4.5		5.5		5.5	
Key way	LW	14		20		25	
	LK	12.5		18		22.5	
	KW	3h9		4h9		5h9	
	KH	3		4		5	
	RH	6.2		8.5		11	
	TP	M3 x 6 (depth)		M4 x 8 (depth)		M5 x 10 (depth)	
Mass (kg)	Without brake	0.65	0.75	1.3	1.4	1.8	1.9
	With brake	0.90	1.00	2.0	2.1	2.5	2.6
Connector/Plug specifications		refer to page A4-120					

* Cautions : Reduce the moment of inertia ratio if high speed response operation is required.

Read the Instruction Manual carefully and understand all precautions and remarks before using the products.

Motor Dimensions

MSMA 1.0kW - 2.0kW

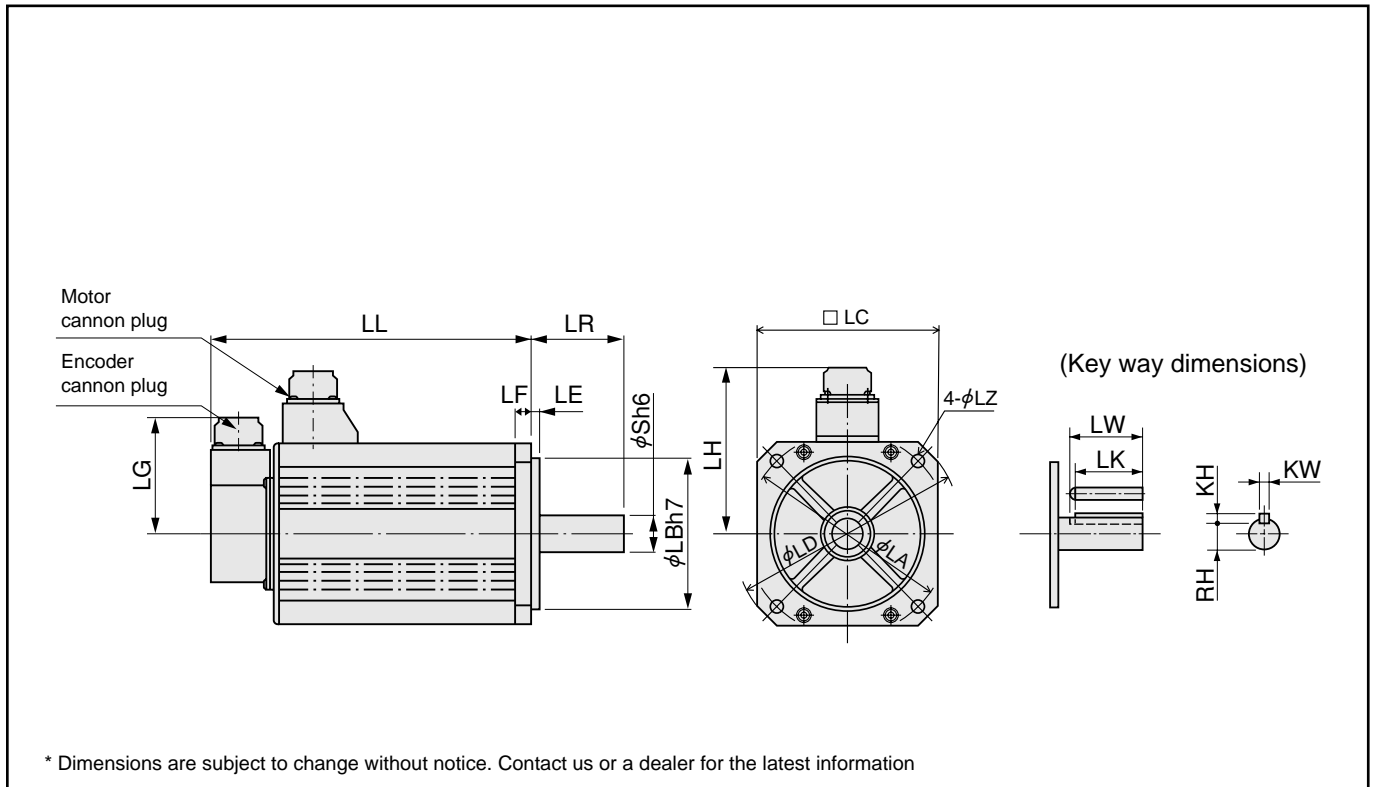

		MSMA series (Low inertia)							
Motor output		1.0kW		1.5kW		2.0kW			
Motor model		MSMA		102P1□	102S1□	152P1□	152S1□	202P1□	202S1□
Rotary encoder specifications		2500P/r Incremental		17-bit Absolute/ Incremental		2500P/r Incremental		17-bit Absolute/ Incremental	
LL	Without brake	175	175	180	180	205	205	205	205
	With brake	200	200	205	205	230	230	230	230
LR		55		55		55		55	
S		19		19		19		19	
LA		100		115		115		115	
LB		80		95		95		95	
LC		90		100		100		100	
LD		120		135		135		135	
LE		3		3		3		3	
LF		7		10		10		10	
LG		84		84		84		84	
LH		98		103		103		103	
LZ		6.6		9		9		9	
Key way	LW	45		45		45		45	
	LK	42		42		42		42	
	KW	6h9		6h9		6h9		6h9	
	KH	6		6		6		6	
	RH	15.5		15.5		15.5		15.5	
Mass (kg)	Without brake	4.5	4.5	5.1	5.1	6.5	6.5	6.5	6.5
	With brake	5.1	5.1	6.5	6.5	7.9	7.9	7.9	7.9
Connector/Plug specifications		refer to page A4-114							

* Cautions : Reduce the moment of inertia ratio if high speed response operation is required.

Read the Instruction Manual carefully and understand all precautions and remarks before using the products.

Motor Dimensions

MSMA 3.0kW - 5.0kW

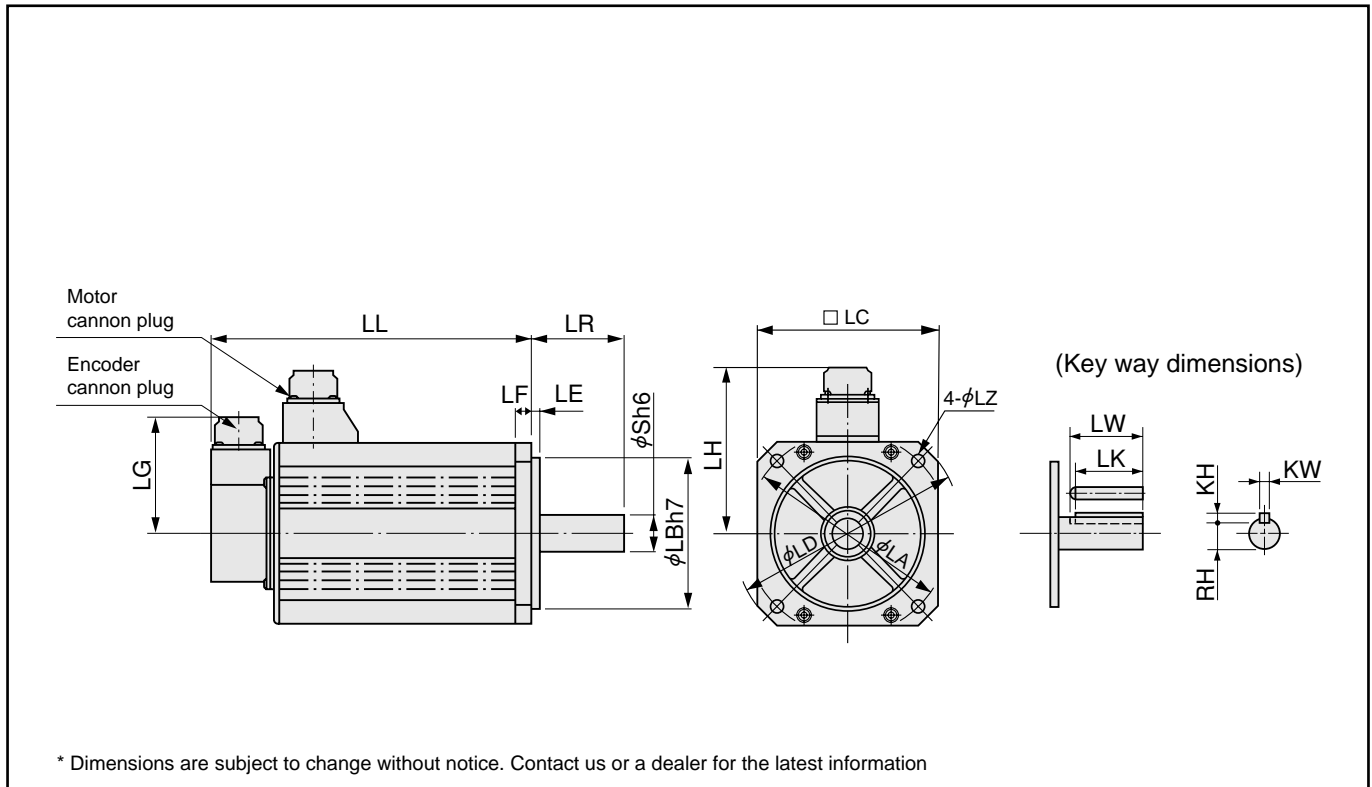

		MSMA series (Low inertia)					
Motor output		3.0kW		4.0kW		5.0kW	
Motor model	MSMA	302P1□	302S1□	402P1□	402S1□	502P1□	502S1□
Rotary encoder specifications		2500P/r Incremental	17-bit Absolute/ Incremental	2500P/r Incremental	17-bit Absolute/ Incremental	2500P/r Incremental	17-bit Absolute/ Incremental
LL	Without brake	217	217	240	240	280	280
	With brake	242	242	265	265	305	305
LR		55		65		65	
S		22		24		24	
LA		130/145 (slot)		145		145	
LB		110		110		110	
LC		120		130		130	
LD		162		165		165	
LE		3		6		6	
LF		12		12		12	
LG		84		84		84	
LH		111		118		118	
LZ		9		9		9	
Key way	LW	45		55		55	
	LK	41		51		51	
	KW	8h9		8h9		8h9	
	KH	7		7		7	
	RH	18		20		20	
Mass (kg)	Without brake	9.3	9.3	12.9	12.9	17.3	17.3
	With brake	11.0	11.0	14.8	14.8	19.2	19.2
Connector/Plug specifications		refer to page A4-114					

* Cautions : Reduce the moment of inertia ratio if high speed response operation is required.

Read the Instruction Manual carefully and understand all precautions and remarks before using the products.

Motor Dimensions

MDMA 1.0kW - 1.5kW

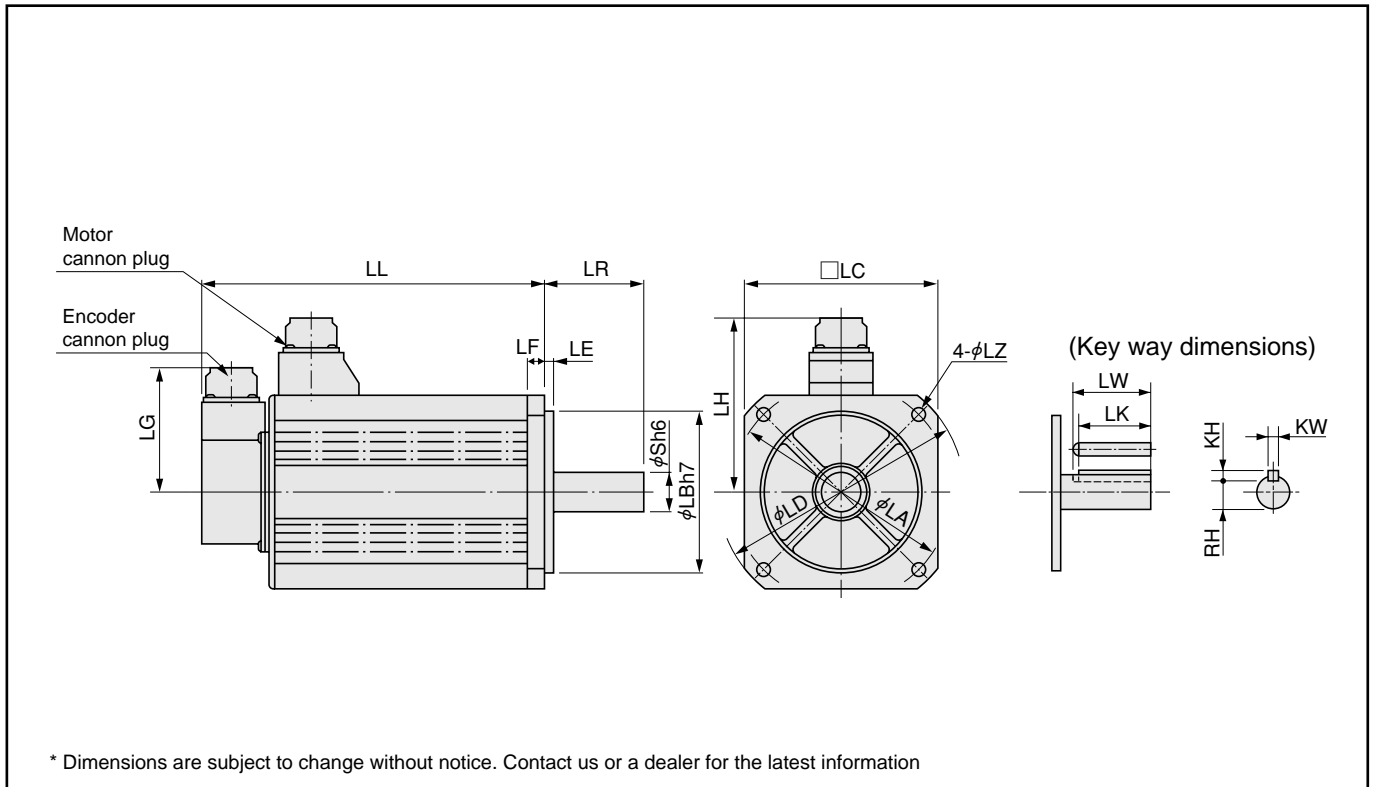

		MDMA series (Middle inertia)			
Motor output		1.0kW		1.5kW	
Motor model	MDMA	102P1□	102S1□	152P1□	152S1□
Rotary encoder specifications		2500P/r Incremental	17-bit Absolute/ Incremental	2500P/r Incremental	17-bit Absolute/ Incremental
LL	Without brake	150	150	175	175
	With brake	175	175	200	200
LR		55		55	
S		22		22	
LA		145		145	
LB		110		110	
LC		130		130	
LD		165		165	
LE		6		6	
LF		12		12	
LG		84		84	
LH		118		118	
LZ		9		9	
Key way	LW	45		45	
	LK	41		41	
	KW	8h9		8h9	
	KH	7		7	
	RH	18		18	
Mass (kg)	Without brake	6.8	6.8	8.5	8.5
	With brake	8.7	8.7	10.1	10.1
Connector/Plug specifications		refer to page A4-114			

* Cautions : Reduce the moment of inertia ratio if high speed response operation is required.

Read the Instruction Manual carefully and understand all precautions and remarks before using the products.

Motor Dimensions

MDMA 2.0kW - 3.0kW

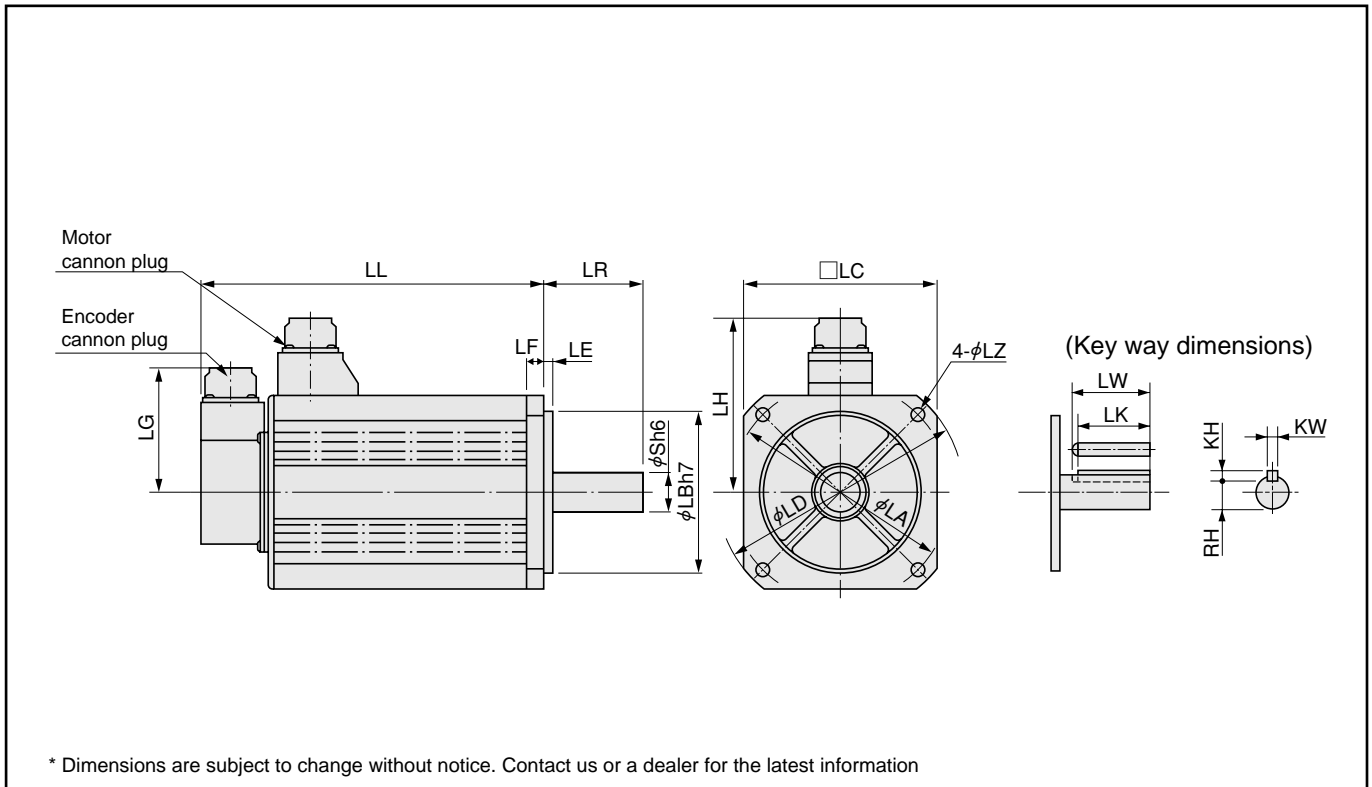

		MDMA series (Middle inertia)			
Motor output		2.0kW		3.0kW	
Motor model		MDMA 202P1□	MDMA 202S1□	MDMA 302P1□	MDMA 302S1□
Rotary encoder specifications		2500P/r Incremental	17-bit Absolute/ Incremental	2500P/r Incremental	17-bit Absolute/ Incremental
LL	Without brake	200	200	250	250
	With brake	225	225	275	275
LR		55		65	
S		22		24	
LA		145		145	
LB		110		110	
LC		130		130	
LD		165		165	
LE		6		6	
LF		12		12	
LG		84		84	
LH		118		118	
LZ		9		9	
Key way	LW	45		55	
	LK	41		51	
	KW	8h9		8h9	
	KH	7		7	
	RH	18		20	
Mass (kg)	Without brake	10.6	10.6	14.6	14.6
	With brake	12.5	12.5	16.5	16.5
Connector/Plug specifications		refer to page A4-114			

* Cautions : Reduce the moment of inertia ratio if high speed response operation is required.

Read the Instruction Manual carefully and understand all precautions and remarks before using the products.

Motor Dimensions

MDMA 4.0kW - 7.5kW

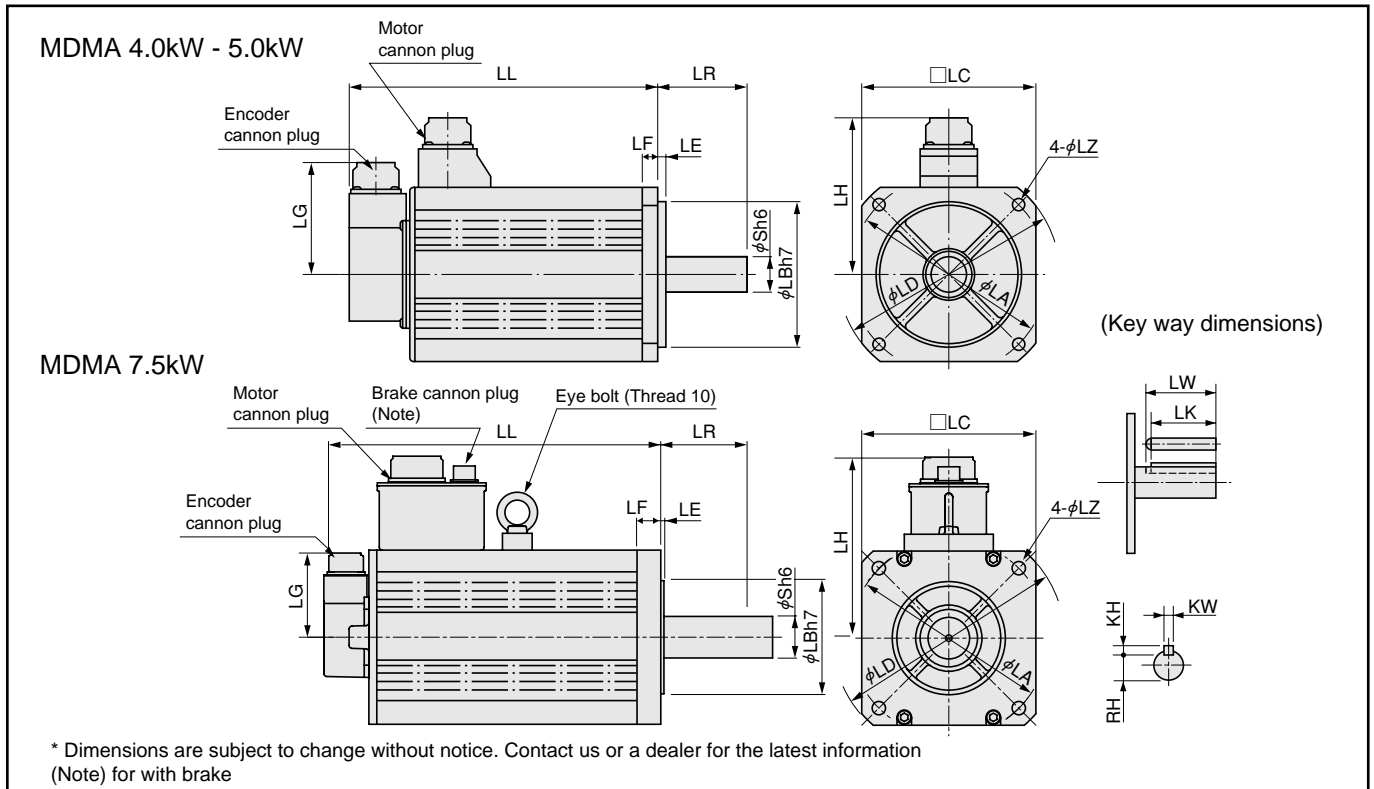

		MDMA series (Middle inertia)					
Motor output		4.0kW		5.0kW		7.5kW	
Motor model	MDMA	402P1□	402S1□	502P1□	502S1□	752P1□	752S1□
Rotary encoder specifications		2500P/r Incremental	17-bit Absolute/ Incremental	2500P/r Incremental	17-bit Absolute/ Incremental	2500P/r Incremental	17-bit Absolute/ Incremental
LL	Without brake	242	242	225	225	340.5	340.5
	With brake	267	267	250	250	380.5	380.5
LR		65		70		113	
S		28		35		42	
LA		165		200		200	
LB		130		114.3		114.3	
LC		150		176		176	
LD		190		233		233	
LE		3.2		3.2		3.2	
LF		18		18		24	
LG		84		84		84	
LH		128		143		183	
LZ		11		13.5		13.5	
Key way	LW	55		55		96	
	LK	51		50		90	
	KW	8h9		10h9		12h9	
	KH	7		8		8	
	RH	24		30		37	
Mass (kg)	Without brake	18.8	18.8	25.0	25.0	41.0	41.0
	With brake	21.3	21.3	28.5	28.5	45.0	45.0
Connector/Plug specifications		refer to page A4-114					

* Cautions : Reduce the moment of inertia ratio if high speed response operation is required.

Read the Instruction Manual carefully and understand all precautions and remarks before using the products.

Motor Dimensions

**MINAS A4
A4P**

MDMA / MGMA
4.0kW - 7.5kW / 900W - 2.0kW

MGMA 900W - 2.0kW

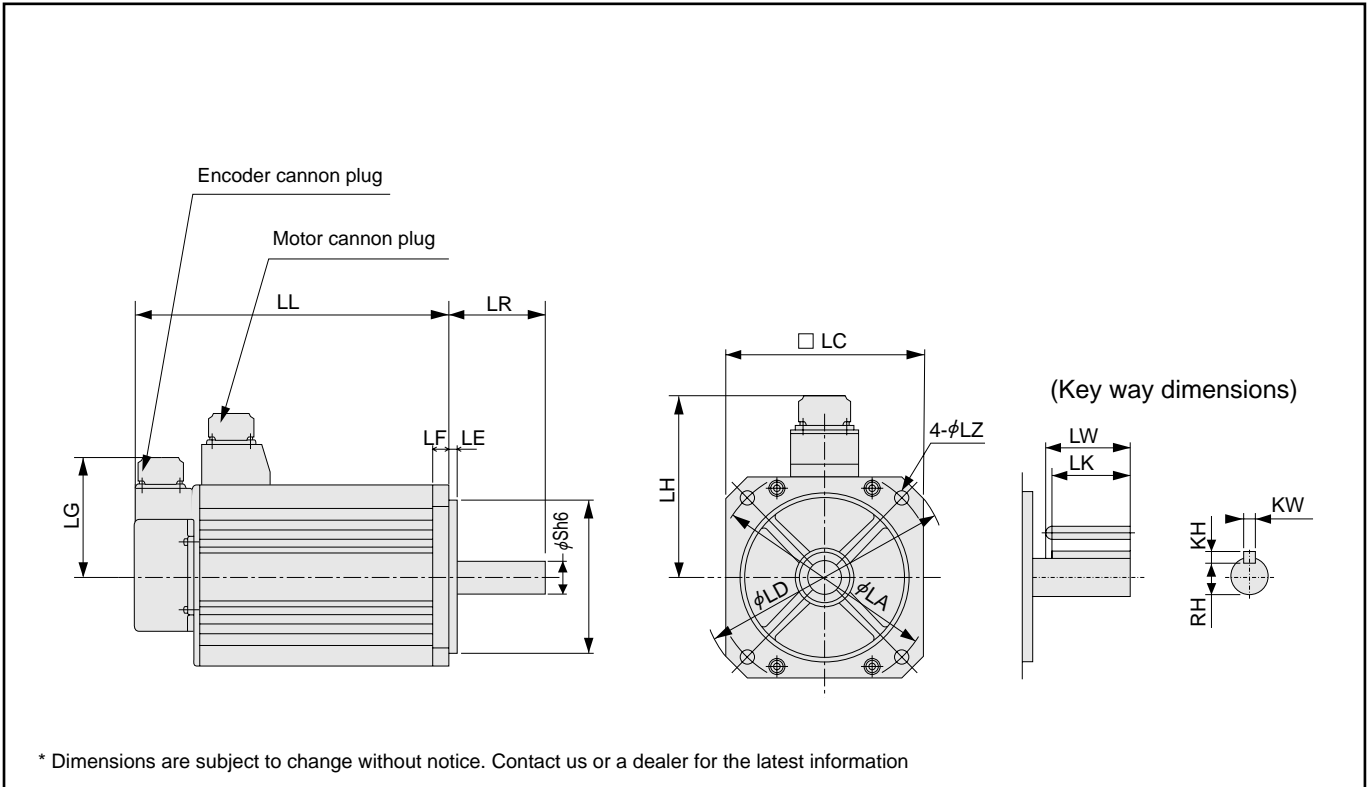

		MGMA series (Middle inertia)			
Motor output		900W		2.0kW	
Motor model		MGMA 092P1□	092S1□	202P1□	202S1□
Rotary encoder specifications		2500P/r Incremental	17-bit Absolute/ Incremental	2500P/r Incremental	17-bit Absolute/ Incremental
LL	Without brake	175	175	182	182
	With brake	200	200	207	207
LR		70		80	
S		22		35	
LA		145		200	
LB		110		114.3	
LC		130		176	
LD		165		233	
LE		6		3.2	
LF		12		18	
LG		84		84	
LH		118		143	
LZ		9		13.5	
Key way	LW	45		55	
	LK	41		50	
	KW	8h9		10h9	
	KH	7		8	
	RH	18		30	
Mass (kg)	Without brake	8.5	8.5	17.5	17.5
	With brake	10.0	10.0	21.0	21.0
Connector/Plug specifications		refer to page A4-114			

* Cautions : Reduce the moment of inertia ratio if high speed response operation is required.

Read the Instruction Manual carefully and understand all precautions and remarks before using the products.

Motor Dimensions

MGMA 3.0kW - 4.5kW

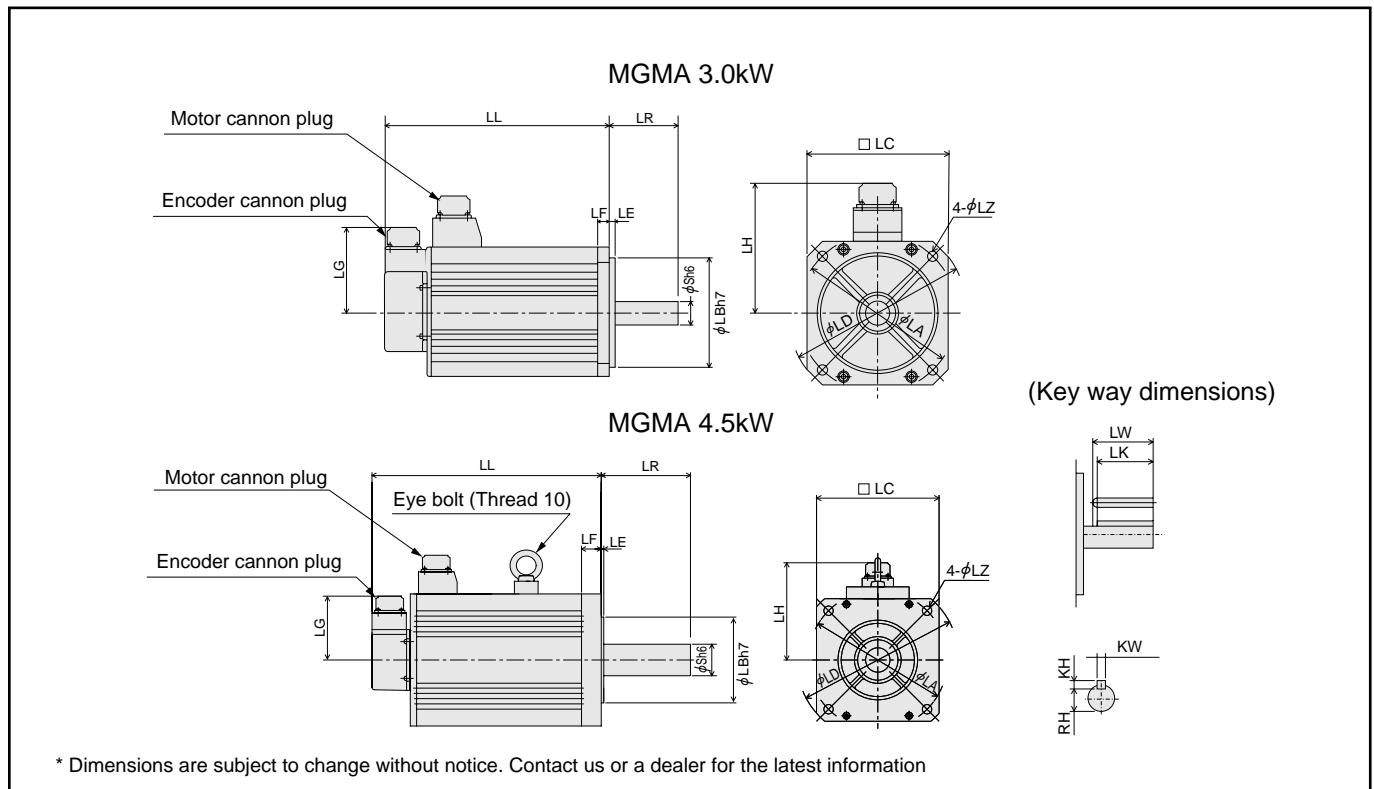

		MGMA series (Middle inertia)			
Motor output		3.0kW		4.5kW	
Motor model	MGMA	302P1□	302S1□	452P1□	452S1□
Rotary encoder specifications		2500P/r Incremental	17-bit Absolute/ Incremental	2500P/r Incremental	17-bit Absolute/ Incremental
LL	Without brake	222	222	300.5	300.5
	With brake	271	271	337.5	337.5
LR		80		113	
S		35		42	
LA		200		200	
LB		114.3		114.3	
LC		176		176	
LD		233		233	
LE		3.2		3.2	
LF		18		24	
LG		84		84	
LH		143		143	
LZ		13.5		13.5	
Key way	LW	55		96	
	LK	50		90	
	KW	10h9		12h9	
	KH	8		8	
	RH	30		37	
Mass (kg)	Without brake	25.0	25.0	34.0	34.0
	With brake	28.5	28.5	39.5	39.5
Connector/Plug specifications		refer to page A4-114			

* Cautions : Reduce the moment of inertia ratio if high speed response operation is required.

Read the Instruction Manual carefully and understand all precautions and remarks before using the products.

Motor Dimensions

**MINAS A4
A4P**

MGMA
3.0kW - 6.0kW

MGMA 6.0kW

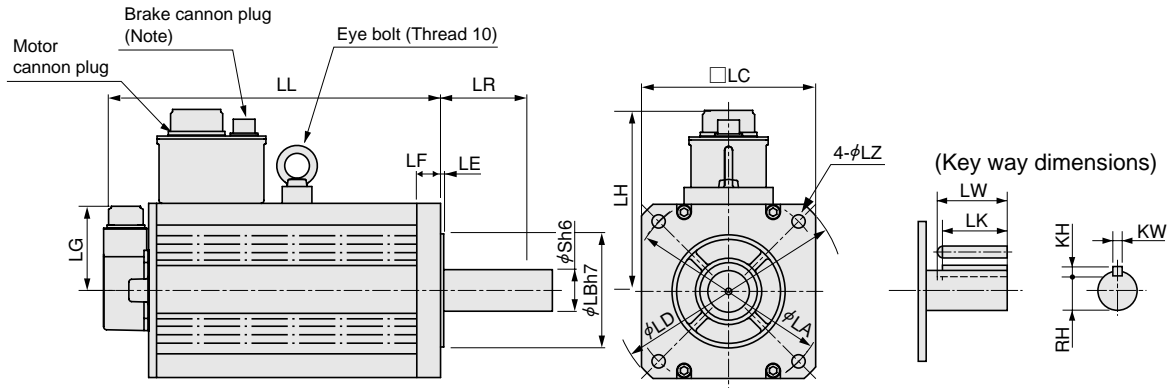

* Dimensions are subject to change without notice. Contact us or a dealer for the latest information (Note) for with brake

		MGMA series (Middle inertia)	
Motor output		6.0kW	
Motor model		602P1 □	602S1 □
Rotary encoder specifications		2500P/r Incremental	17-bit Absolute/ Incremental
LL	Without brake	340.5	340.5
	With brake	380.5	380.5
LR		113	
S		42	
LA		200	
LB		114.5	
LC		176	
LD		233	
LE		3.2	
LF		24	
LG		84	
LH		183	
LZ		13.5	
Key way	LW	96	
	LK	90	
	KW	12h9	
	KH	8	
	RH	37	
Mass (kg)	Without brake	41.0	41.0
	With brake	45.0	45.0
Connector/Plug specifications		refer to page A4-114	

* Cautions : Reduce the moment of inertia ratio if high speed response operation is required.

Read the Instruction Manual carefully and understand all precautions and remarks before using the products.

Motor Dimensions

MFMA 400W - 1.5kW

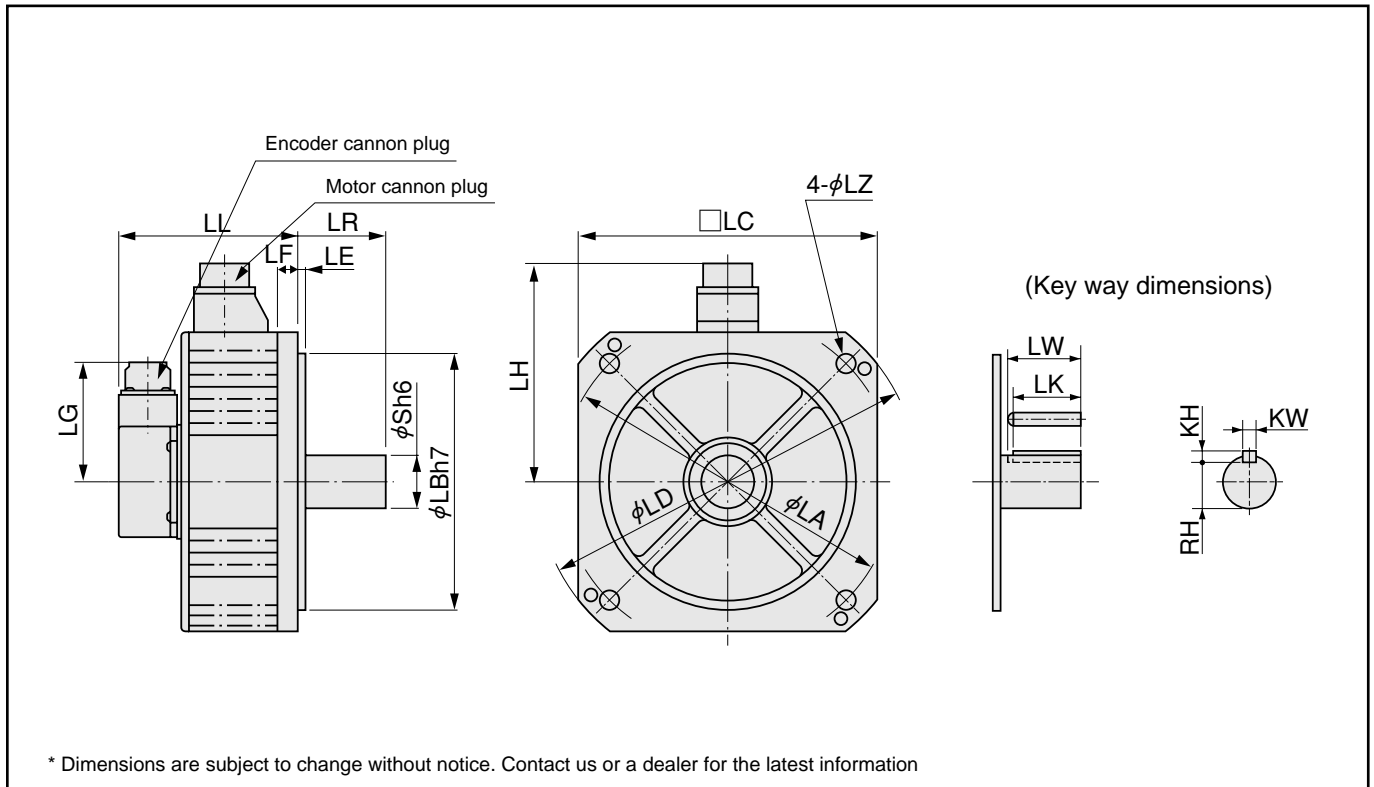

		MFMA series (Middle inertia)			
Motor output		400W		1.5kW	
Motor model		MFMA 042P1 □	MFMA 042S1 □	MFMA 152P1 □	MFMA 152S1 □
Rotary encoder specifications		2500P/r Incremental	17-bit Absolute/ Incremental	2500P/r Incremental	17-bit Absolute/ Incremental
LL	Without brake	120	120	145	145
	With brake	145	145	170	170
LR		55		65	
S		19		35	
LA		145		200	
LB		110		114.3	
LC		130		176	
LD		165		233	
LE		6		3.2	
LF		12		18	
LG		84		84	
LH		118		143	
LZ		9		13.5	
Key way	LW	45		55	
	LK	42		50	
	KW	6h9		10h9	
	KH	6		8	
	RH	15.5		30	
Mass (kg)	Without brake	4.7	4.7	11.0	11.0
	With brake	6.7	6.7	14.0	14.0
Connector/Plug specifications		refer to page A4-114			

* Cautions : Reduce the moment of inertia ratio if high speed response operation is required.

Read the Instruction Manual carefully and understand all precautions and remarks before using the products.

Motor Dimensions

MFMA 2.5kW - 4.5kW

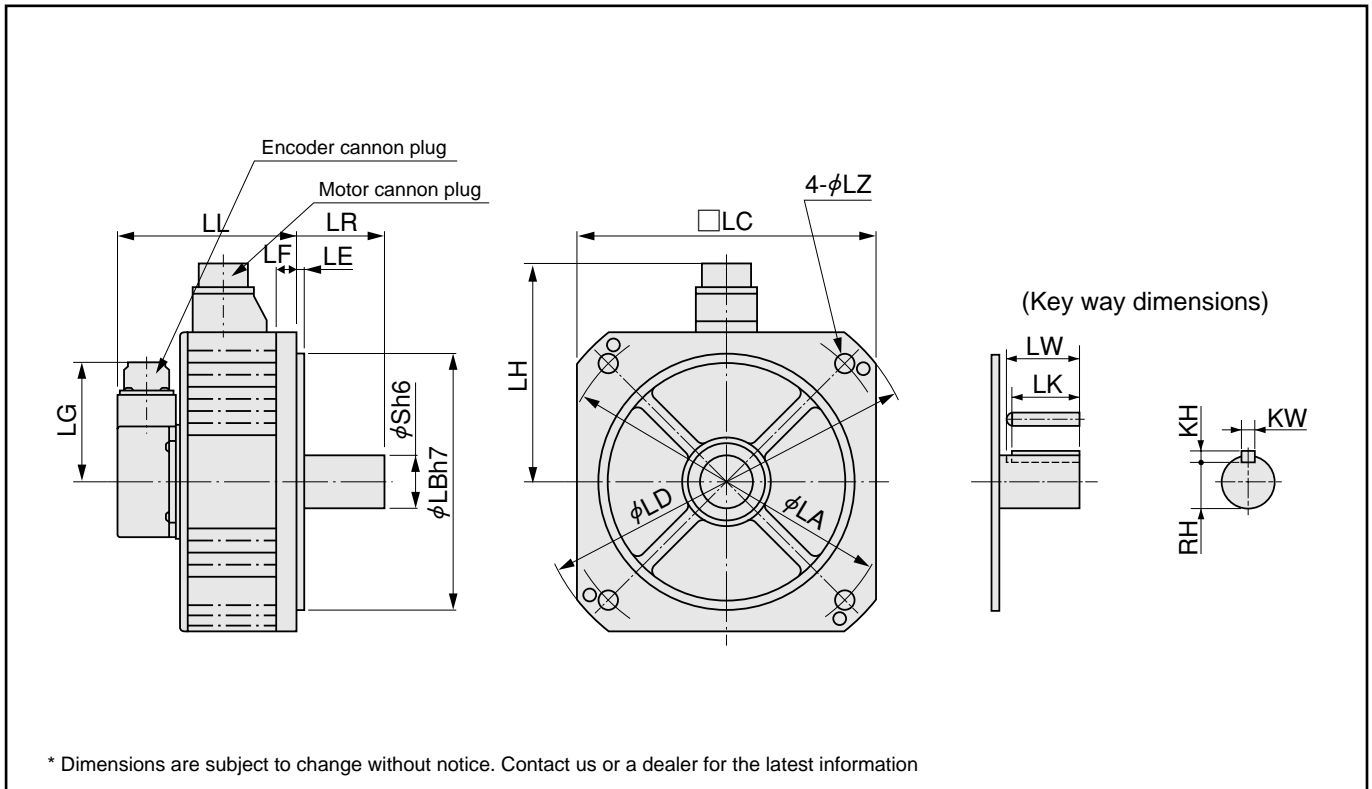

		MFMA series (Middle inertia)			
Motor output		2.5kW		4.5kW	
Motor model	MFMA	252P1□	252S1□	452P1□	452S1□
Rotary encoder specifications		2500P/r Incremental	17-bit Absolute/ Incremental	2500P/r Incremental	17-bit Absolute/ Incremental
LL	Without brake	139	139	163	163
	With brake	166	166	194	194
LR		65		70	
S		35		35	
LA		235		235	
LB		200		200	
LC		220		220	
LD		268		268	
LE		4		4	
LF		16		16	
LG		84		84	
LH		164		164	
LZ		13.5		13.5	
Key way	LW	55		55	
	LK	50		50	
	KW	10h9		10h9	
	KH	8		8	
	RH	30		30	
Mass (kg)	Without brake	14.8	14.8	19.9	19.9
	With brake	17.5	17.5	24.3	24.3
Connector/Plug specifications		refer to page A4-114			

* Cautions : Reduce the moment of inertia ratio if high speed response operation is required.

Read the Instruction Manual carefully and understand all precautions and remarks before using the products.

Motor Dimensions

MHMA 500W - 1.5kW

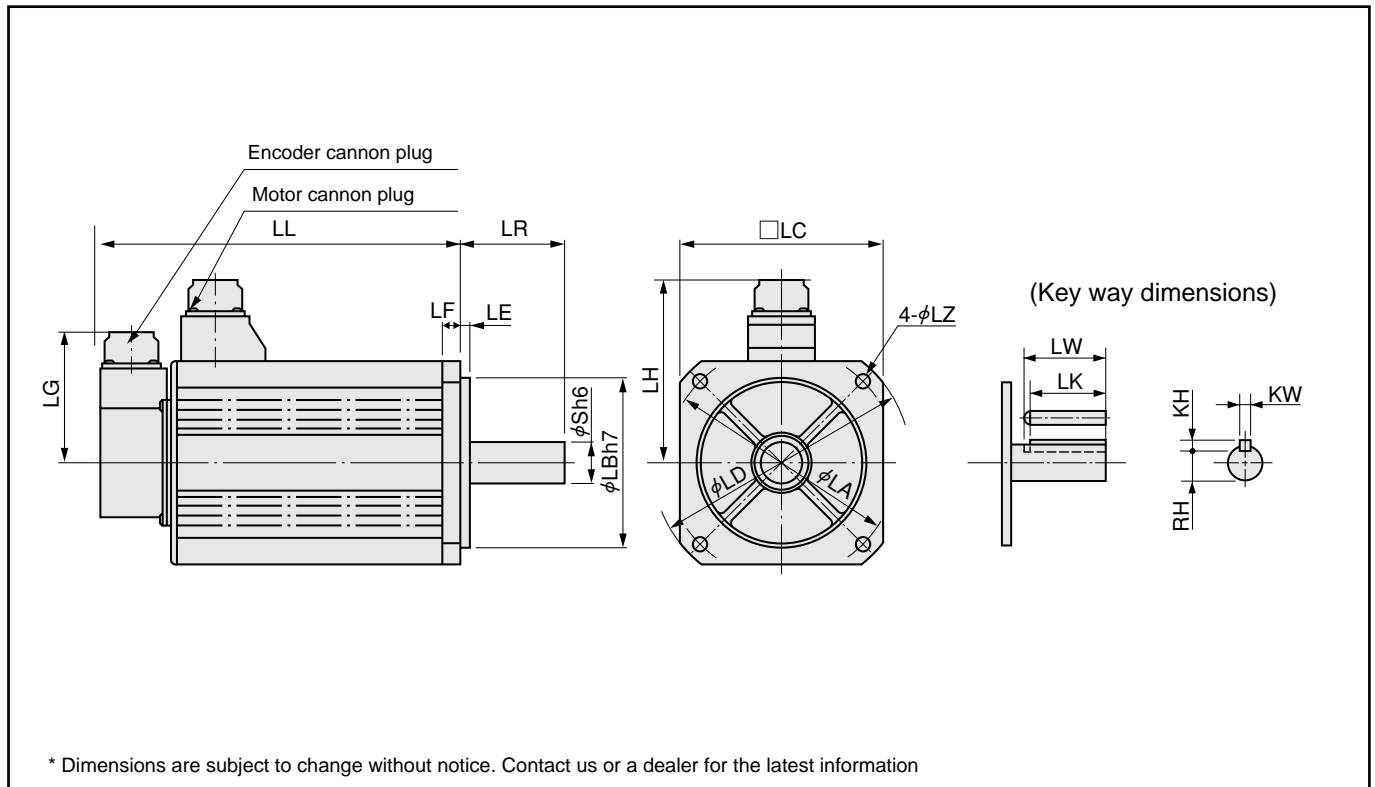

		MHMA series (High inertia)					
Motor output		500W		1.0kW		1.5kW	
Motor model	MHMA	052P1□	052S1□	102P1□	102S1□	152P1□	152S1□
Rotary encoder specifications		2500P/r Incremental	17-bit Absolute/ Incremental	2500P/r Incremental	17-bit Absolute/ Incremental	2500P/r Incremental	17-bit Absolute/ Incremental
LL	Without brake	150	150	175	175	200	200
	With brake	175	175	200	200	225	225
LR		70		70		70	
S		22		22		22	
LA		145		145		145	
LB		110		110		110	
LC		130		130		130	
LD		165		165		165	
LE		6		6		6	
LF		12		12		12	
LG		84		84		84	
LH		118		118		118	
LZ		9		9		9	
Key way	LW	45		45		45	
	LK	41		41		41	
	KW	8h9		8h9		8h9	
	KH	7		7		7	
	RH	18		18		18	
Mass (kg)	Without brake	5.3	5.3	8.9	8.9	10.0	10.0
	With brake	6.9	6.9	9.5	9.5	11.6	11.6
Connector/Plug specifications		refer to page A4-114					

* Cautions : Reduce the moment of inertia ratio if high speed response operation is required.

Read the Instruction Manual carefully and understand all precautions and remarks before using the products.

Motor Dimensions

MHMA 2.0kW - 5.0kW

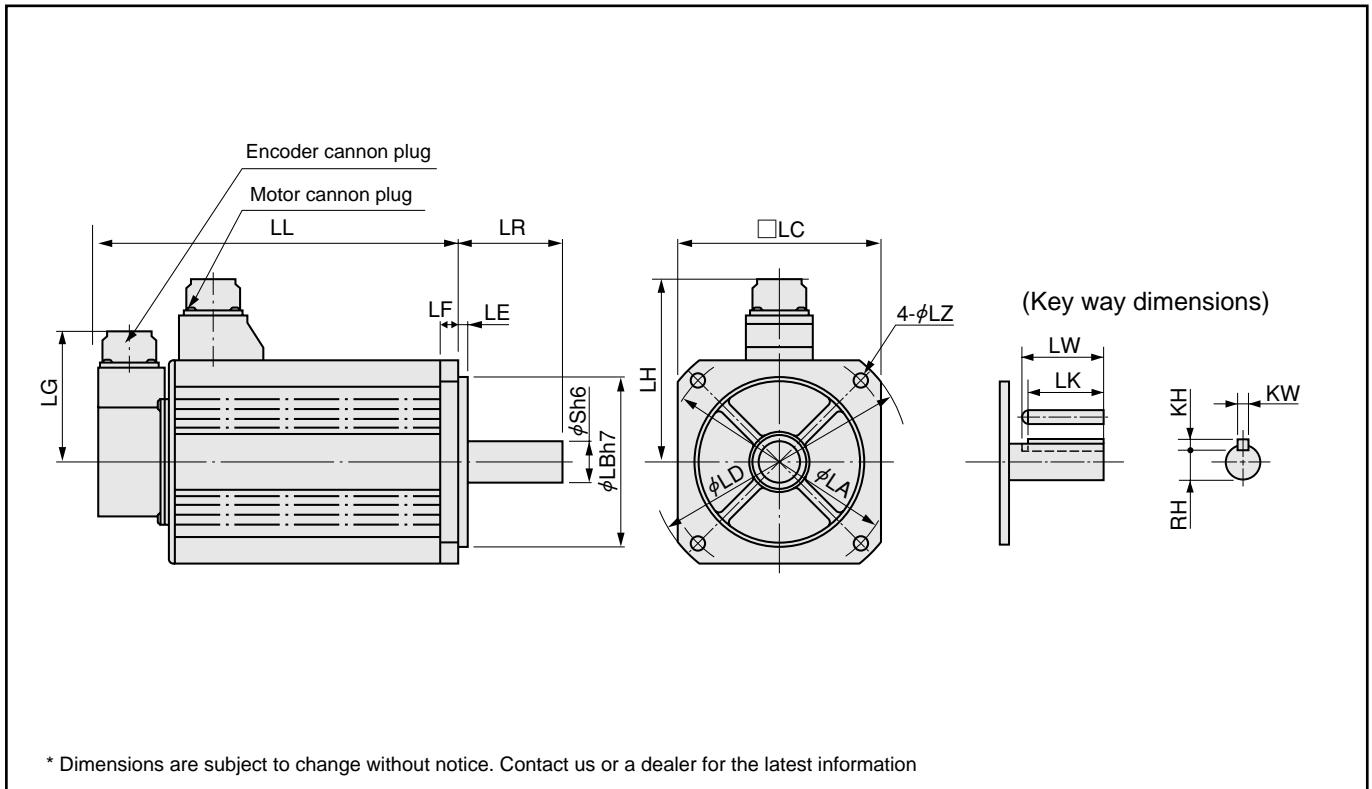

		MHMA series (High inertia)									
Motor output		2.0kW		3.0kW		4.0kW		5.0kW			
Motor model		MHMA		202P1□	202S1□	302P1□	302S1□	402P1□	402S1□	502P1□	502S1□
Rotary encoder specifications		2500P/r Incremental	17-bit Absolute/ Incremental	2500P/r Incremental	17-bit Absolute/ Incremental	2500P/r Incremental	17-bit Absolute/ Incremental	2500P/r Incremental	17-bit Absolute/ Incremental	2500P/r Incremental	17-bit Absolute/ Incremental
LL	Without brake	190	190	205	205	230	230	255	255	280	280
	With brake	215	215	230	230	255	255	280	280		
LR		80		80		80		80			
S		35		35		35		35			
LA		200		200		200		200			
LB		114.3		114.3		114.3		114.3			
LC		176		176		176		176			
LD		233		233		233		233			
LE		3.2		3.2		3.2		3.2			
LF		18		18		18		18			
LG		84		84		84		84			
LH		143		143		143		143			
LZ		13.5		13.5		13.5		13.5			
Key way	LW	55		55		55		55			
	LK	50		50		50		50			
	KW	10h9		10h9		10h9		10h9			
	KH	8		8		8		8			
	RH	30		30		30		30			
Mass (kg)	Without brake	16.0	16.0	18.2	18.2	22.0	22.0	26.7	26.7		
	With brake	19.5	19.5	21.7	21.7	25.5	25.5	30.2	30.2		
Connector/Plug specifications		refer to page A4-114									

* Cautions : Reduce the moment of inertia ratio if high speed response operation is required.

Read the Instruction Manual carefully and understand all precautions and remarks before using the products.

Motor Dimensions

MHMA 7.5kW

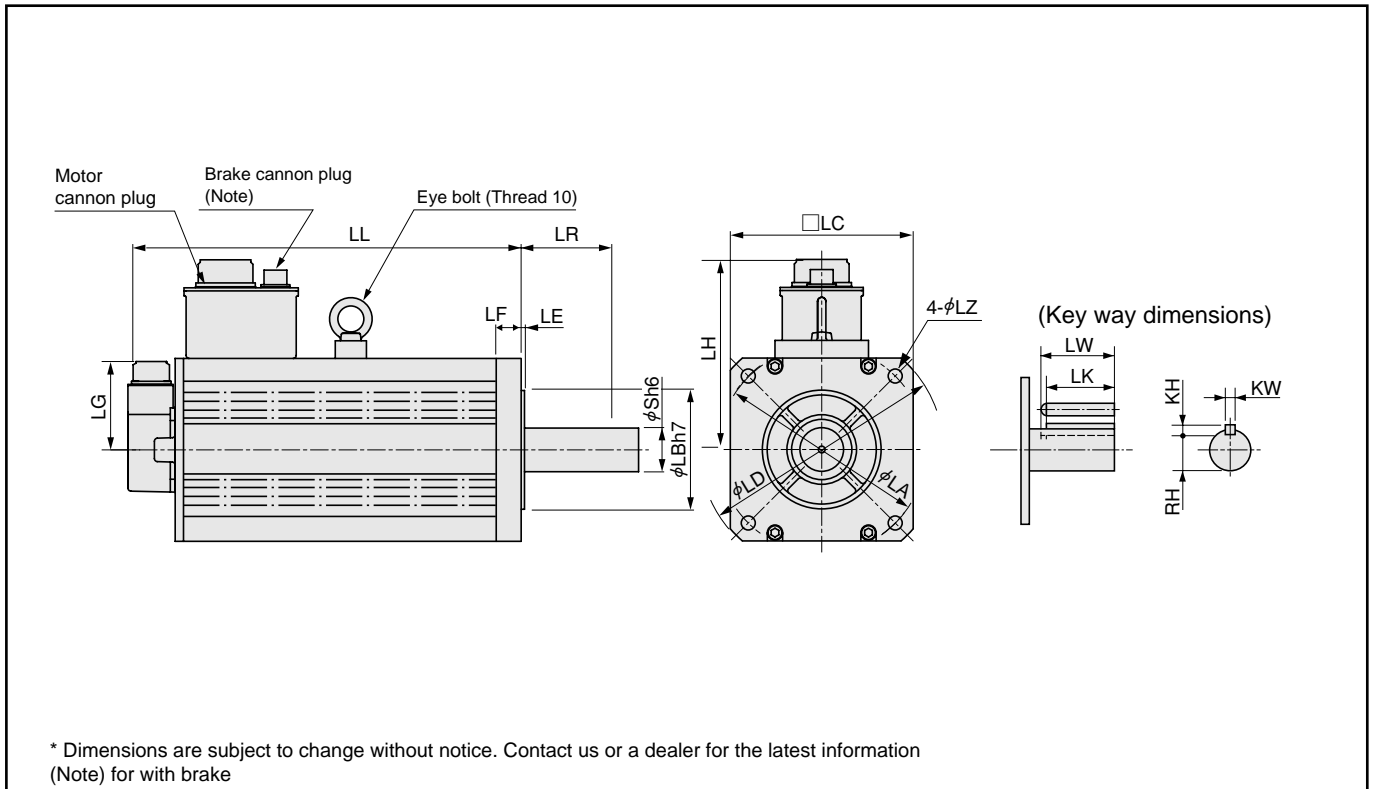

		MHMA series (High inertia)	
Motor output		7.5kW	
Motor model		MHMA 752P1□	752S1□
Rotary encoder specifications		2500P/r Incremental	17-bit Absolute/ Incremental
LL	Without brake	380.5	380.5
	With brake	420.5	420.5
LR		113	
S		42	
LA		200	
LB		114.3	
LC		176	
LD		233	
LE		3.2	
LF		24	
LG		84	
LH		183	
LZ		13.5	
Key way	LW	96	
	LK	90	
	KW	12h9	
	KH	8	
	RH	37	
Mass (kg)	Without brake	43.5	43.5
	With brake	47.5	47.5
Connector/Plug specifications		refer to page A4-114	

* Cautions : Reduce the moment of inertia ratio if high speed response operation is required.

Read the Instruction Manual carefully and understand all precautions and remarks before using the products.

Conformity to CE and UL

Compliance to EC and EMC Directives

EC Directives

The EC Directives apply to all such electronic products as those having specific functions and have been exported to EU and directly sold to general consumers. Those products are required to conform to the EU unified standards and to furnish the CE marking on the products.

MINAS AC Servos conforms to the EC Directives for Low Voltage Equipment so that the machine incorporating our servos has an easy access to the conformity to relevant EC Directives for the machine.

EMC Directives

MINAS Servo System conforms to relevant standards under EMC Directives setting up certain model (condition) with certain locating distance and wiring of the servo motor and the driver. And actual working condition often differs from this model condition especially in wiring and grounding. Therefore, in order for the machine to conform to the EMC Directives, especially for noise emission and noise terminal voltage, it is necessary to examine the machine incorporating our servos.

Conformed Standards

Subject	Conformed Standard	
Motor	IEC60034-1	
Motor and driver	EN50178	UL508C
	EN55011	Radio Disturbance Characteristics of Industrial, Scientific and Medical (ISM) Radio-Frequency Equipment
	EN61000-6-2	Immunity for Industrial Environments
	IEC61000-4-2	Electrostatic Discharge Immunity Test
	IEC61000-4-3	Radio Frequency Electromagnetic Field Immunity Test
	IEC61000-4-4	Electric High-Speed Transition Phenomenon/Burst Immunity Test
	IEC61000-4-5	Lightening Surge Immunity Test
	IEC61000-4-6	High Frequency Conduction Immunity Test
	IEC61000-4-11	Instantaneous Outage Immunity Test

IEC : International Electrotechnical Commission
 EN : Europaischen Normen
 EMC : Electromagnetic Compatibility
 UL : Underwriters Laboratories
 CSA : Canadian Standards Association

Composition of peripheral equipment

<Precautions in using options>

Use options correctly after reading operation manuals of the options to better understand the precautions.

Take care not to apply excessive stress to each optional part.

Installation environment

Use the MINAS driver in environment of Pollution Degree

1 or 2 prescribed in IEC-60664-1

(e.g. Install the driver in control panel with IP54 protection structure.)

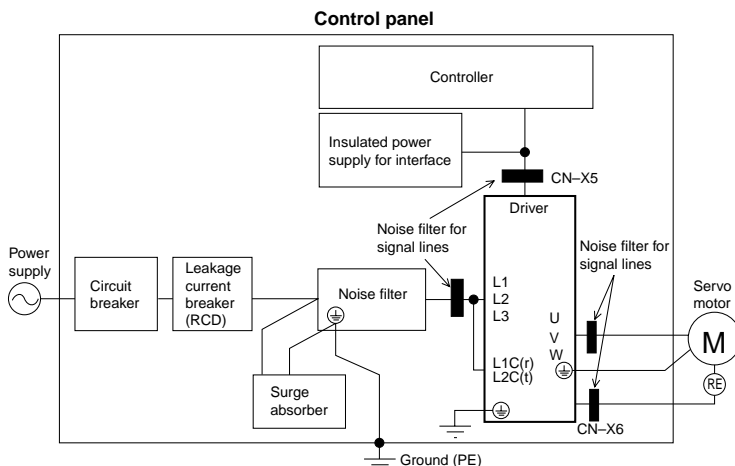

Power supply

100V system : Single phase 100V $\begin{matrix} +10\% \\ -15\% \end{matrix}$ -115V $\begin{matrix} +10\% \\ -15\% \end{matrix}$ 50/60Hz (Frame A to C)

200V system : Single 200V $\begin{matrix} +10\% \\ -15\% \end{matrix}$ -240V $\begin{matrix} +10\% \\ -15\% \end{matrix}$ 50/60Hz (Frame A to B)

200V system : Single/3- phase 200V $\begin{matrix} +10\% \\ -15\% \end{matrix}$ -240V $\begin{matrix} +10\% \\ -15\% \end{matrix}$ 50/60Hz (Frame C to D)

200V system : 3- phase 200V $\begin{matrix} +10\% \\ -15\% \end{matrix}$ -230V $\begin{matrix} +10\% \\ -15\% \end{matrix}$ 50/60Hz (Frame E to F)

(1) This product is designed to be used under Overvoltage

Category (Installation Category) II of EN50178 :1997.

Install a surge absorber which conforms to EN61643-11 :

2002 and other relevant standards at the power entry when

you want to use this product under Overvoltage Category

(Installation Category) III .

(2) For a interface power supply, use an insulated one with

12 to 24 VDC which conforms to CE Marking or EN Standards.

Circuit breaker

Connect a circuit breaker which conforms to IEC standards and is UL recognized (listed and UL marked), between the power supply and the noise filter.

Noise filter

When you install one noise filter in the power supply for multi-axes application, consult with the manufacture of the filter.

Option part No.	Part No.	Manufacturer
DV0P4170	SUP-EK5-ER-6	Okaya Electric Industries Co.
DV0P4180	3SUP-HQ10-ER-6	
DV0P4220	3SUP-HU30-ER-6	
DV0P3410	3SUP-HL50-ER-6B	

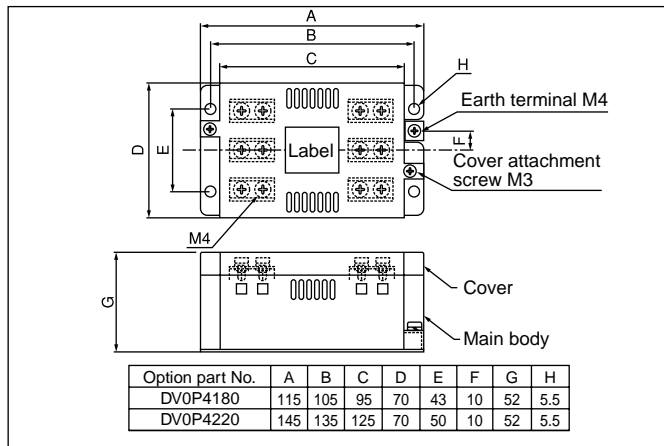
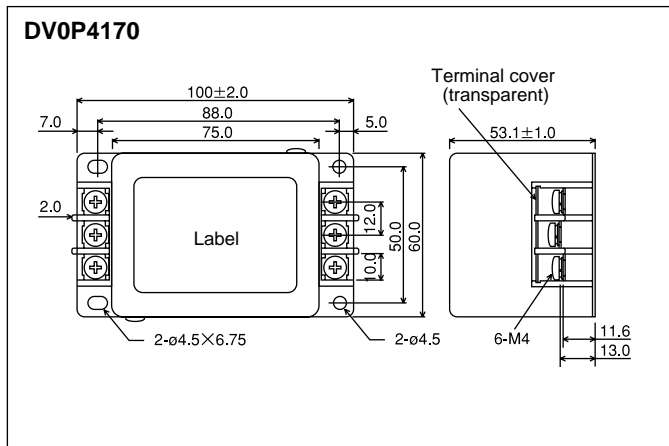

Surge absorber

Install a surge absorber at primary side of the noise filter.

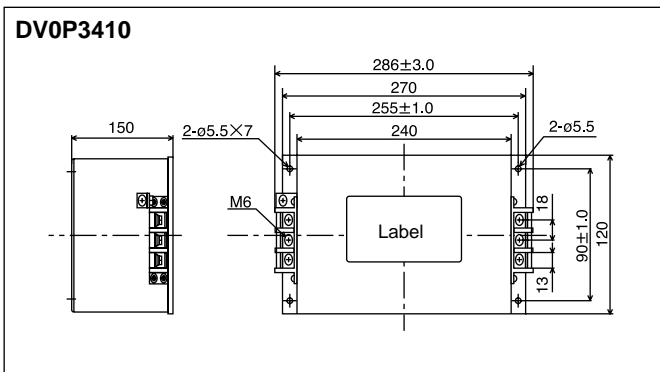

Option part No.	Driver voltage spec	Part No.	Manufacturer
DV0P1450	3-phase, 200V	R · A · V-781BXZ-4	Okaya Electric

Option part No.	Driver voltage spec	Part No.	Manufacturer
DV0P4190	Single phase, 100V, 200V	R · A · V-781BWZ-4	Okaya Electric

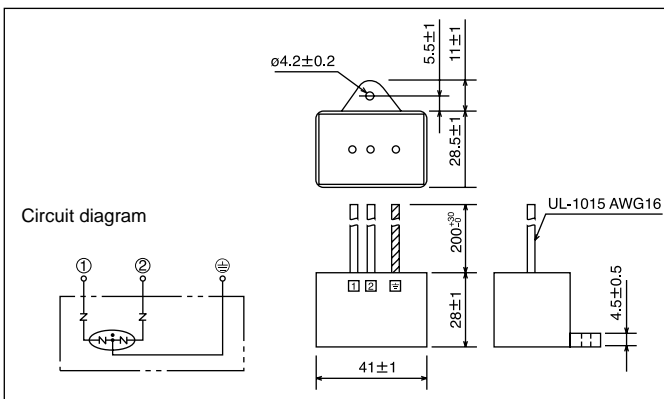
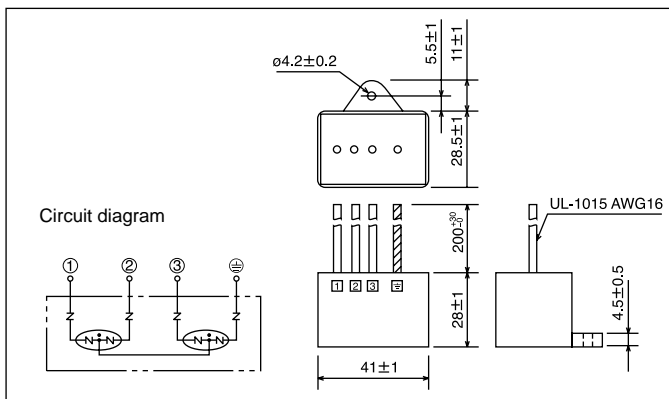

<Remarks>

Remove this surge absorber when you perform dielectric test on the machine, or surge absorber might be damaged.

Conformity to CE and UL

Noise filter for signal lines

Install noise filters for signal lines to all cables (Power line, motor cable, encoder cable, interface cable)

Option part No.	Part No.	Manufacturer
DV0P1460	ZCAT3035-1330	TDK Corp.

<Caution>

Fix the signal line noise filter in place to eliminate excessive stress to the cables.

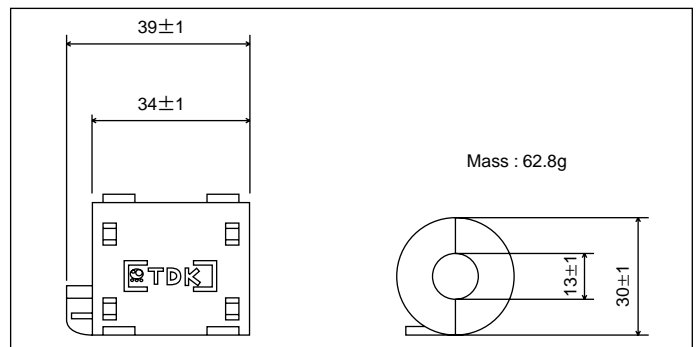

Ground-fault breaker

Install a B-type ground-fault breaker (RCD) at primary side of the power supply of the driver.

Grounding

- (1) Connect the protective earth terminal of the driver (\oplus) and protective earth terminal of the control panel (PE) without fail to prevent electrical shocks.
- (2) Do not co-clamp to the protective earth terminals (\oplus). Two protective earth terminals are provided.

Conformity to UL Standards

Observe the following conditions ((1) and (2)) to make the system conform to UL508C (File No. E164620).

- (1) Use Minas driver in environment of Pollution Degree 1 or 2 prescribed in IEC-60664-1.
(e.g. Install in the control panel with IP54 protective structure)
- (2) Connect the UL recognized (UL Listed, UL marked) circuit breaker or UL recognized (UL Listed, UL marked) fuse between the power supply and noise filter.

IP65 Rating

MINAS A4 A4P

Conformity to CE and UL IP65 Rating

- MSMD, MQMA and MAMA motors conform to IP65 rating except for the connector and shaft through hole.
- For MSMA, MDMA, MGMA, MFMA and MHMA motors, customer to supply the plug and cable clamp which conform to IP65 rating.
(Optional connector kits for encoder cable and motor cable do not provide IP65 rating.)

Motor		Motor side Receptacle type (or equivalent)	Plug and clamp (Customer to supply) manufactured by Japan Aviation Electronics Ind.				
Series	Output (kW)		Plug		Cable clamp type (or equivalent)		
			Straight type (or equivalent)	Angle type (L-shape) (or equivalent)			
Without brake	MSMA	1.0 - 2.0	JL04V-2E20-4PE-B-R	JL04V-6A20-4SE-EB-R	JL04V-8A20-4SE-EB-R	JL04-2022CK (14)-R	
		3.0 - 5.0	JL04HV-2E22-22PE-B-R	JL04V-6A22-22SE-EB-R	JL04V-8A22-22SE-EB-R		
	MDMA	1.0 - 2.0	JL04V-2E20-4PE-B-R	JL04V-6A20-4SE-EB-R	JL04V-8A20-4SE-EB-R		JL04-2022CK (14)-R
		3.0 - 5.0	JL04HV-2E22-22PE-B-R	JL04V-6A22-22SE-EB-R	JL04V-8A22-22SE-EB-R		
	MGMA	7.5	JL04V-2E32-17PE-B-R	N/MS3106B-32-17S	N/MS3108 32-17S		N/MS3057-20A
		0.9	JL04V-2E20-4PE-B-R	JL04V-6A20-4SE-EB-R	JL04V-8A20-4SE-EB-R		JL04-2022CK (14)-R
		2.0 - 4.5	JL04HV-2E22-22PE-B-R	JL04V-6A22-22SE-EB-R	JL04V-8A22-22SE-EB-R		
	MHMA	6.0	JL04V-2E32-17PE-B-R	N/MS3106B-32-17S	N/MS3108 32-17S	N/MS3057-20A	
		0.5 - 1.5	JL04V-2E20-4PE-B-R	JL04V-6A20-4SE-EB-R	JL04V-8A20-4SE-EB-R	JL04-2022CK (14)-R	
		2.0 - 5.0	JL04HV-2E22-22PE-B-R	JL04V-6A22-22SE-EB-R	JL04V-8A22-22SE-EB-R		
	MFMA	7.5	JL04V-2E32-17PE-B-R	N/MS3106B-32-17S	N/MS3108 32-17S	N/MS3057-20A	
		0.4 - 1.5	JL04V-2E20-18PE-B-R	JL04V-6A20-18SE-EB-R	JL04V-8A20-18SE-EB-R	JL04-2022CK (14)-R	
Without brake	MSMA	2.5 - 4.5	JL04V-2E24-11PE-B-R	JL04V-6A24-11SE-EB-R	JL04V-8A24-11SE-EB-R	JL04-2428CK (17)-R	
		1.0 - 2.0	JL04V-2E20-18PE-B-R	JL04V-6A20-18SE-EB-R	JL04V-8A20-18SE-EB-R	JL04-2022CK (14)-R	
With brake	MSMA	3.0 - 5.0	JL04V-2E24-11PE-B-R	JL04V-6A24-11SE-EB-R	JL04V-8A24-11SE-EB-R	JL04-2428CK (17)-R	
		1.0 - 2.0	JL04V-2E20-18PE-B-R	JL04V-6A20-18SE-EB-R	JL04V-8A20-18SE-EB-R	JL04-2022CK (14)-R	
	MDMA	3.0 - 5.0	JL04V-2E24-11PE-B-R	JL04V-6A24-11SE-EB-R	JL04V-8A24-11SE-EB-R	JL04-2428CK (17)-R	
		7.5	Motor	JL04V-2E32-17PE-B-R	N/MS3106B 32-17S	N/MS3108B 32-17S	N/MS3057-20A
	MGMA	7.5	Brake	N/MS3102A 14S-2P	N/MS3106B 14S-2S	N/MS3108B 14S-2S	N/MS3057-6A
			0.9	JL04V-2E20-18PE-B-R	JL04V-6A20-18SE-EB-R	JL04V-8A20-18SE-EB-R	JL04-2022CK (14)-R
		2.0 - 4.5	JL04V-2E24-11PE-B-R	JL04V-6A24-11SE-EB-R	JL04V-8A24-11SE-EB-R	JL04-2428CK (17)-R	
	MHMA	6.0	Motor	JL04V-2E32-17PE-B-R	N/MS3106B 32-17S	N/MS3108B 32-17S	N/MS3057-20A
		6.0	Brake	N/MS3102A 14S-2P	N/MS3106B 14S-2S	N/MS3108B 14S-2S	N/MS3057-6A
			0.5 - 1.5	JL04V-2E20-18PE-B-R	JL04V-6A20-18SE-EB-R	JL04V-8A20-18SE-EB-R	JL04-2022CK (14)-R
	MFMA	2.0 - 5.0	JL04V-2E24-11PE-B-R	JL04V-6A24-11SE-EB-R	JL04V-8A24-11SE-EB-R	JL04-2428CK (17)-R	
			7.5	Motor	JL04V-2E32-17PE-B-R	N/MS3106B 32-17S	N/MS3108B 32-17S
7.5		Brake	N/MS3102A 14S-2P	N/MS3106B 14S-2S	N/MS3108B 14S-2S	N/MS3057-6A	
	0.4 - 1.5	JL04V-2E20-18PE-B-R	JL04V-6A20-18SE-EB-R	JL04V-8A20-18SE-EB-R	JL04-2022CK (14)-R		
Without brake	MFMA	2.5 - 4.5	JL04V-2E24-11PE-B-R	JL04V-6A24-11SE-EB-R	JL04V-8A24-11SE-EB-R	JL04-2428CK (17)-R	
		Encoder	N/MS3102A 20-29P	JA06A-20-29S-J1-EB-R	JA08A-20-29S-J1-EB-R	JL04-2022CK (14)-R	

Note) MDMA 7.5kW, MGMA 6kW and MHMA 7.5kW do not provide IP65 rating.

Options

Cable part No. designation

Encoder cable

1 2 3 4 5 6 7 8 9 10 11 12
M F E C A 0 0 5 0 E A M

Cable end (Driver side)

D	Molex connector (MINAS A4,A4P series, incremental)
E	Molex connector (MINAS A4,A4P series, absolute)
M	Molex connector (MINAS A4,A4P series, E series)

Cable end (Encoder side)

S	S-type cannon plug
A	AMP connector

Cable type

E	PVC cable with shield by Oki Electric Cable Co., 0.20mm ² x 8P, 3P
---	---

Cable length

0030	3m
0050	5m
0100	10m
0200	20m

Type classification

MFECA : Encoder cable

Motor cable

1 2 3 4 5 6 7 8 9 10 11 12
M F M C A 0 0 5 2 F C T

Cable end at driver side

D	Plus clamp terminal for MINAS A4,A4P by Phoenix contact
T	Clamp terminal

Cable end at motor side

E	4 pole AMP connector
C	4 pin S type cannon plug

Cable type

E	ROBOTOP 4-wire by Daiden Co., Ltd.
F	ROBOTOP 6-wire by Daiden Co., Ltd.
G	ROBOTOP 2-wire by Daiden Co., Ltd.

Cross section of cable core

0	0.75mm ²
1	1.25mm ²
2	2.0mm ²
3	3.5mm ²

Cable length

003	3m
005	5m
010	10m
020	20m

Type classification

A	Standard
B	Special
⋮	Design order

AC servo motor cable

• Pin configuration for encoder connector

MSMA
MDMA
MFMA
MHMA
MGMA

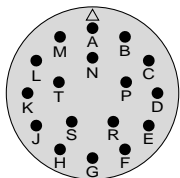

N/MS3102A20-29P

• Specifications of 2500P/r incremental encoder

PIN No.	Content	PIN No.	Content
A	NC	K	PS
B	NC	L	PS
C	NC	M	NC
D	NC	N	NC
E	NC	P	NC
F	NC	R	NC
G	EOV	S	NC
H	E5V	T	NC
J	Frame GND		

MSMA
MDMA
MFMA
MHMA
MGMA

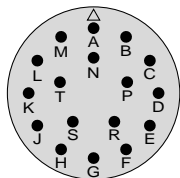

N/MS3102A20-29P

• Specifications of 17bit absolute/incremental encoder

PIN No.	Content	PIN No.	Content
A	NC	K	PS
B	NC	L	PS
C	NC	M	NC
D	NC	N	NC
E	NC	P	NC
F	NC	R	NC
G	EOV	S	BAT-*
H	E5V	T	BAT+*
J	Frame GND		

*Connection to Pin-S and T are not required when used in incremental.

• Pin configuration for motor/brake connector (with brake)

MSMA 1kW, 1.5kW, 2kW
MDMA 1kW, 1.5kW, 2kW
MFMA 400W, 1.5kW
MHMA 500W, 1kW, 1.5kW
MGMA 900W

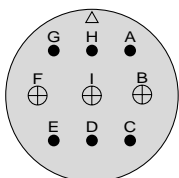

JL04V-2E20-18PE-B-R
(by Japan Aviation Electronics or equivalent)

PIN No.	Content
G	Brake
H	Brake
A	NC
F	U-phase
I	V-phase
B	W-phase
E	Ground
D	Ground
C	NC

MSMA 3kW, 4kW, 5kW
MDMA 3kW, 4kW, 5kW
MFMA 2.5kW, 4.5kW
MHMA 2kW, 3kW, 4kW, 5kW
MGMA 2kW, 3kW, 4.5kW

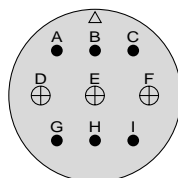

JL04V-2E24-11PE-B-R
(by Japan Aviation Electronics or equivalent)

PIN No.	Content
A	Brake
B	Brake
C	NC
D	U-phase
E	V-phase
F	W-phase
G	Ground
H	Ground
I	NC

MDMA 7.5kW
MGMA 6kW
MHMA 7.5kW

Motor Cable

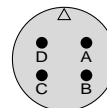

JL04V-2E32-17PE-B-R
(by Japan Aviation Electronics or equivalent)

PIN No.	Content
A	U-phase
B	V-phase
C	W-phase
D	Ground

Brake Cable

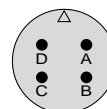

N/MS3102A 14S-2P
(by Japan Aviation Electronics or equivalent)

PIN No.	Content
A	Brake
B	Brake
C	NC
D	NC

• Pin configuration for motor/brake connector (without brake)

MSMA 1kW, 1.5kW, 2kW
MDMA 1kW, 1.5kW, 2kW
MHMA 500W, 1kW, 1.5kW
MGMA 900W

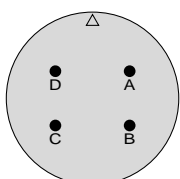

JL04V-2E20-4PE-B-R
(by Japan Aviation Electronics or equivalent)

PIN No.	Content
A	U-phase
B	V-phase
C	W-phase
D	Ground

MSMA 3kW, 4kW, 5kW
MDMA 3kW, 4kW, 5kW
MHMA 2kW, 3kW, 4kW, 5kW
MGMA 2kW, 3kW, 4.5kW

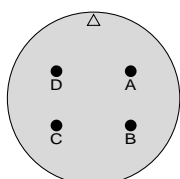

JL04V-2E22-22PE-B-R
(by Japan Aviation Electronics or equivalent)

PIN No.	Content
A	U-phase
B	V-phase
C	W-phase
D	Ground

MDMA 7.5kW
MGMA 6kW
MHMA 7.5kW

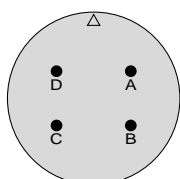

JL04V-2E32-17PE-B-R
(by Japan Aviation Electronics or equivalent)

PIN No.	Content
A	U-phase
B	V-phase
C	W-phase
D	Ground

MFMA 400W, 1.5kW

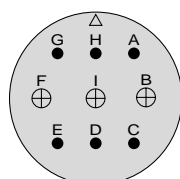

JL04V-2E20-18PE-B-R
(by Japan Aviation Electronics or equivalent)

PIN No.	Content
G	NC
H	NC
A	NC
F	U-phase
I	V-phase
B	W-phase
E	Ground
D	Ground
C	NC

MFMA 2.5kW, 4.5kW

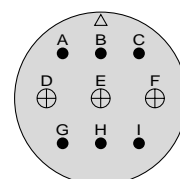

JL04V-2E24-11PE-B-R
(by Japan Aviation Electronics or equivalent)

PIN No.	Content
A	NC
B	NC
C	NC
D	U-phase
E	V-phase
F	W-phase
G	Ground
H	Ground
I	NC

Do not connect anything to NC pins.

Options

Encoder cable

MFECA0**0EAE

MSMD50W - 750W, MQMA100W - 400W, MAMA100W - 750W
17-bit absolute encoder, with battery holder

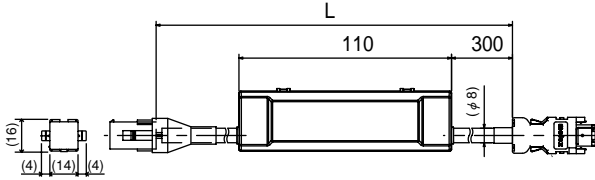

Title	Part No. (Manufacturer's)	Manufacturer	L (m)	Part No.
Connector	55100-0600	Molex Inc.	3	MFECA0030EAE
	or 55100-0670			
Connector	172161-1	Tyco Electronics, AMP	5	MFECA0050EAE
Connector pin	170365-1			
Cable	0.20mm ² X4P	Oki Electric Cable Co.	10	MFECA0100EAE
			20	MFECA0200EAE

Note) Battery for absolute encoder is an option.

MFECA0**0ESE

MSMA, MDMA, MHMA, MGMA, MFMA
17-bit absolute encoder, with battery holder

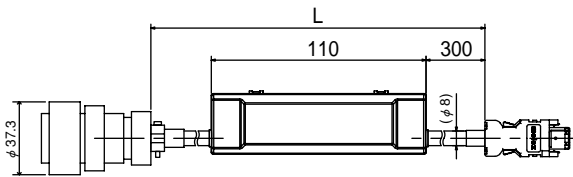

Title	Part No. (Manufacturer's)	Manufacturer	L (m)	Part No.
Connector	55100-0600	Molex Inc.	3	MFECA0030ESE
	or 55100-0670			
Straight plug	N/MS3106B20-29S	Japan Aviation	5	MFECA0050ESE
Cable clamp	N/MS3057-12A	Electronics Industry Ltd.		
Cable	0.20mm ² X4P	Oki Electric Cable Co.	10	MFECA0100ESE
			20	MFECA0200ESE

Note) Battery for absolute encoder is an option.

MFECA0**0EAD

MSMD50W - 750W, MQMA100W - 400W, MAMA100W - 750W
17-bit incremental encoder, without battery holder

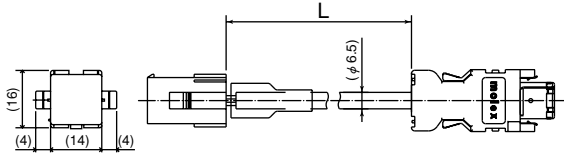

Title	Part No. (Manufacturer's)	Manufacturer	L (m)	Part No.
Connector	55100-0600	Molex Inc.	3	MFECA0030EAD
	or 55100-0670			
Connector	172161-1	Tyco Electronics, AMP	5	MFECA0050EAD
Connector pin	170365-1			
Cable	0.20mm ² X3P	Oki Electric Cable Co.	10	MFECA0100EAD
			20	MFECA0200EAD

MFECA0**0ESD

MSMA, MDMA, MHMA, MGMA, MFMA
17-bit incremental/2500P/r encoder, without battery holder

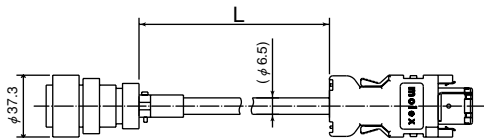

Title	Part No. (Manufacturer's)	Manufacturer	L (m)	Part No.
Connector	55100-0600	Molex Inc.	3	MFECA0030ESD
	or 55100-0670			
Straight plug	N/MS3106B20-29S	Japan Aviation	5	MFECA0050ESD
Cable clamp	N/MS3057-12A	Electronics Industry Ltd.		
Cable	0.20mm ² X3P	Oki Electric Cable Co.	10	MFECA0100ESD
			20	MFECA0200ESD

MFECA0**0EAM

MSMD50W - 750W, MQMA100W - 400W, MAMA100W - 750W
2500P/r encoder, without battery holder

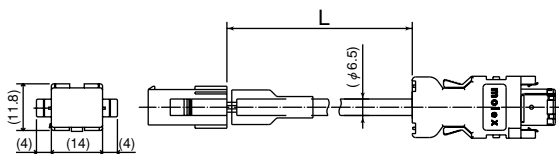

Title	Part No. (Manufacturer's)	Manufacturer	L (m)	Part No.
Connector	55100-0600	Molex Inc.	3	MFECA0030EAM
	or 55100-0670			
Connector	172160-1	Tyco Electronics, AMP	5	MFECA0050EAM
Connector pin	170365-1			
Cable	0.20mm ² X3P	Oki Electric Cable Co.	10	MFECA0100EAM
			20	MFECA0200EAM

Motor cable (ROBO TOP® 105°C, 600V, DP)

ROBO TOP ® is a trade mark of Daiden Co., Ltd.

MFMCA0**0EED

MSMD50W - 750W, MQMA100W - 400W, MAMA100W - 750W

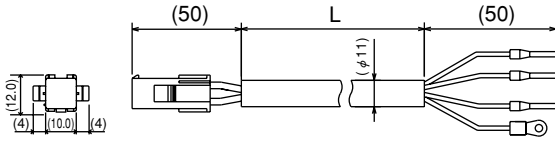

Title	Part No. (Manufacturer's)	Manufacturer
Connector	172159-1	Tyco Electronics, AMP
Connector pin	170366-1	
Rod terminal	AI0.75-8GY	Phoenix
Nylon insulated roundterminal	N1.25-M4	J.S.T. Mfg. Co., Ltd.
Cable	ROBO-TOP 600V 0.75mm ²	Daiden Co., Ltd.

L (m)	Part No.
3	MFMCA0030EED
5	MFMCA0050EED
10	MFMCA0100EED
20	MFMCA0200EED

MFMCDO**2ECD

MSMA1.0kW - 1.5kW, MDMA1.0kW - 1.5kW
MHMA500W - 1.5kW, MGMA900W

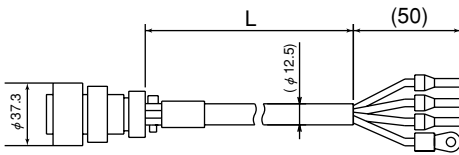

Title	Part No. (Manufacturer's)	Manufacturer
Straight plug	JL04V-6A20-4SE-EB-R	Japan Aviation
Cable clamp	JL04-2022CK(14)-R	Electronics Industry Ltd.
Rod terminal	AI2.5-8BU	Phoenix
Nylon insulated roundterminal	N2-M4	J.S.T. Mfg. Co., Ltd.
Cable	ROBO-TOP 600V 2.0mm ²	Daiden Co., Ltd.

L (m)	Part No.
3	MFMCD0032ECD
5	MFMCD0052ECD
10	MFMCD0102ECD
20	MFMCD0202ECD

MFMCDO**2ECT

MSMA2.0kW, MDMA2.0kW

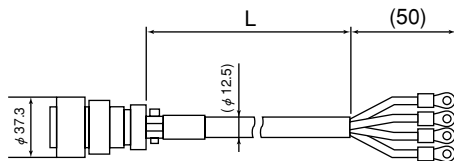

Title	Part No. (Manufacturer's)	Manufacturer
Straight plug	JL04V-6A20-4SE-EB-R	Japan Aviation
Cable clamp	JL04-2022CK(14)-R	Electronics Industry Ltd.
Nylon insulated roundterminal	N2-5	J.S.T. Mfg. Co., Ltd.
Cable	ROBO-TOP 600V 2.0mm ²	Daiden Co., Ltd.

L (m)	Part No.
3	MFMCD0032ECT
5	MFMCD0052ECT
10	MFMCD0102ECT
20	MFMCD0202ECT

MFMCAO**3ECT

MSMA3.0kW - 5.0kW, MDMA3.0kW - 5.0kW
MHMA2.0kW - 5.0kW, MGMA2.0kW - 4.5kW

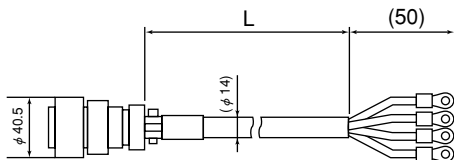

Title	Part No. (Manufacturer's)	Manufacturer
Straight plug	JL04V-6A22-22SE-EB-R	Japan Aviation
Cable clamp	JL04-2022CK(14)-R	Electronics Industry Ltd.
Nylon insulated roundterminal	N5.5-5	J.S.T. Mfg. Co., Ltd.
Cable	ROBO-TOP 600V 3.5mm ²	Daiden Co., Ltd.

L (m)	Part No.
3	MFMCA0033ECT
5	MFMCA0053ECT
10	MFMCA0103ECT
20	MFMCA0203ECT

MFMCAO**2ECD

MFMA400W - 1.5kW

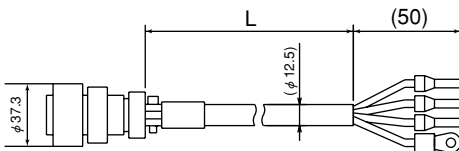

Title	Part No. (Manufacturer's)	Manufacturer
Straight plug	JL04V-6A20-18SE-EB-R	Japan Aviation
Cable clamp	JL04-2022CK(14)-R	Electronics Industry Ltd.
Rod terminal	AI2.5-8BU	Phoenix
Nylon insulated roundterminal	N2-M4	J.S.T. Mfg. Co., Ltd.
Cable	ROBO-TOP 600V 2.0mm ²	Daiden Co., Ltd.

L (m)	Part No.
3	MFMCA0032ECD
5	MFMCA0052ECD
10	MFMCA0102ECD
20	MFMCA0202ECD

MFMCDO**3ECT

MFMA2.5kW - 4.5kW

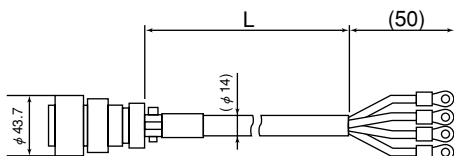

Title	Part No. (Manufacturer's)	Manufacturer
Straight plug	JL04V-6A24-11SE-EB-R	Japan Aviation
Cable clamp	JL04-2428CK(17)-R	Electronics Industry Ltd.
Nylon insulated roundterminal	N5.5-5	J.S.T. Mfg. Co., Ltd.
Cable	ROBO-TOP 600V 3.5mm ²	Daiden Co., Ltd.

L (m)	Part No.
3	MFMCD0033ECT
5	MFMCD0053ECT
10	MFMCD0103ECT
20	MFMCD0203ECT

Options

Brake cable (ROBO TOP® 105°C, 600V, DP)

MFMCB00GET**

MSMD 50W - 750W
MQMA100W - 400W
MAMA 100W - 750W

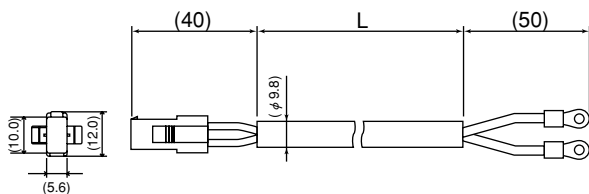

Title	Part No. (Manufacturer's)	Manufacturer	L (m)	Part No.
Connector	172157-1	Japan Aviation	3	MFMCB0030GET
Connector pin	170366-1,170362-1	Electronics Industry Ltd.	5	MFMCB0050GET
Nylon insulated roundterminal	N1.25-M4	J.S.T. Mfg. Co., Ltd.	10	MFMCB0100GET
Cable	ROBO-TOP 600V 0.75mm ²	Daiden Co., Ltd.	20	MFMCB0200GET

Motor cable (with brake) (ROBO TOP® 105°C, 600V, DP)

ROBO TOP® is a trade mark of Daiden Co., Ltd.

MFMCAO2FCD**

MSMA1.0kW -1.5kW,MDMA1.0kW - 1.5kW
MHMA 500W -1.5kW,MFMA 400W - 1.5kW
MGMA 900W

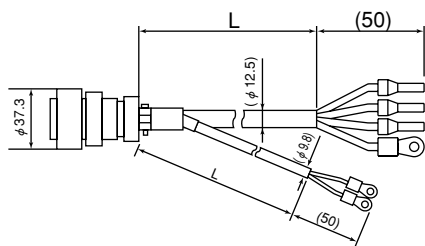

Title	Part No. (Manufacturer's)	Manufacturer	L (m)	Part No.
Straight plug	JL04V-6A20-18SE-EB-R	Japan Aviation	3	MFMCA0032FCD
Cable clamp	JL04-2022CK(14)-R	Electronics Industry Ltd.	5	MFMCA0052FCD
Rod terminal	AI2.5-8BU	Phoenix	10	MFMCA0102FCD
Nylon insulated roundterminal	N2-M4	J.S.T. Mfg. Co., Ltd.	20	MFMCA0202FCD
	N1.25-M4			
Cable	RROBO-TOP 600V 2.0mm ² or ROBO-TOP 600V 0.75mm ²	Daiden Co., Ltd.		

MFMCAO2FCT**

MSMA2.0kW,MDMA2.0kW

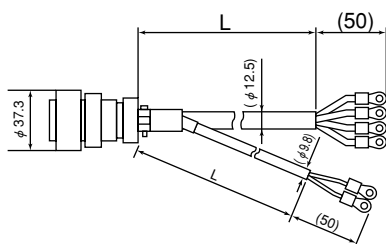

Title	Part No. (Manufacturer's)	Manufacturer	L (m)	Part No.
Straight plug	JL04V-6A20-18SE-EB-R	Japan Aviation	3	MFMCA0032FCT
Cable clamp	JL04-2022CK(14)-R	Electronics Industry Ltd.	5	MFMCA0052FCT
Nylon insulated roundterminal	N2-5	J.S.T. Mfg. Co., Ltd.	10	MFMCA0102FCT
	N1.25-M4		20	MFMCA0202FCT
Cable	ROBO-TOP 600V 2.0mm ² or ROBO-TOP 600V 0.75mm ²	Daiden Co., Ltd.		

MFMCAO3FCT**

MSMA 3.0kW - 5.0kW,MDMA 3.0kW - 5.0kW
MHMA 2.0kW - 5.0kW ,MFMA 2.5kW - 4.5kW
MGMA 2.0kW - 4.5kW

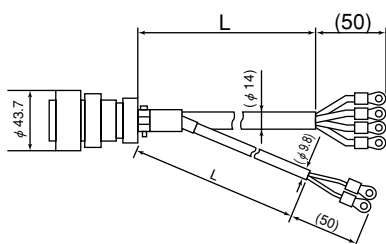

Title	Part No. (Manufacturer's)	Manufacturer	L (m)	Part No.
Straight plug	JL04V-6A24-11SE-EB-R	Japan Aviation	3	MFMCA0033FCT
Cable clamp	JL04-2428CK(17)-R	Electronics Industry Ltd.	5	MFMCA0053FCT
Nylon insulated roundterminal	N5.5-5	J.S.T. Mfg. Co., Ltd.	10	MFMCA0103FCT
	N1.25-M4		20	MFMCA0203FCT
Cable	ROBO-TOP 600V 3.5mm ² or ROBO-TOP 600V 0.75mm ²	Daiden Co., Ltd.		

Connector kit for external peripheral equipments

●MINAS A4

1) Part No. **DV0P4350**

2) Components	Title	Part No.	Number	Manufacturer	Note
	Connector	54306-5011 or 54306-5019	1	Molex Inc.	For CN X5 (50-pins)
	Connector cover	54331-0501	1		

3) Pin Configuration(50-pins) (viewed from the soldering side)

26 ZERO SPD/ VS-SEL	28 DIV / INTSPD3	30 CL INTSPD2	32 C- MODE	34 S- RDY-	36 ALM-	38 COIN-/ AT-SPEED-	40 TLC	42 IM	44 PULSH1	46 SIGNH1	48 OB+	50 FG
27 GAIN /TL-SEL	29 SRV -ON	31 A- CLR	33 INH /INTSPD1	35 S- RDY+	37 ALM+	39 COIN+/ AT-SPEED+	41 COM-	43 SP	45 PULSH2	47 SIGNH2	49 OB-	
1 OPC1	3 PULS1	5 SIGN1	7 COM+	9 CCWL DIVZ	11 BRK- OFF+	13 GND	15 GND	17 GND	19 CZ	21 OA+	23 OZ+	25 GND
2 OPC2	4 PULS2	6 SIGN2	8 CWL	10 BRK- OFF-	12 ZSP	14 SPR/TRQR /SPL	16 CCWTL /TRQR	18 CWTL	20 NC	22 OA-	24 OZ-	

<Cautions>

1. Check the stamped pin No. on the connector body while making a wiring.
2. For the function of each signal title or its symbol, refer to the wiring example of connector, CN I/F.
3. Check the stamped pin-No. on the Connector body while marking a wiring.

●MINAS A4P

1) Part No. **DV0P4500**

2) Components	Title	Part No.	Number	Manufacturer	Note
	Connector	54306-3611 or 54306-3619	1	Molex Inc.	For CN X5 (36-pins)
	Connector cover	54331-0361	1		

3) Pin Configuration(50-pins) (viewed from the soldering side)

19 CCWL	21 Z-LS	23 SRV-ON	25 EX-IN2	27 COIN/ DCLON	29 P1OUT	31 P4OUT	33 P16OUT	35 (NC)
20 CWL	22 EX-IN1	24 STB	26 GND	28 BUSY	30 P2OUT	32 P8OUT	34 P32OUT	36 BRK-OFF
1 COM +	3 P1IN	5 P4IN	7 P16IN	9 OZ +	11 OA +	13 DB +	15 ALM	17 COM -
2 EMG- STP	4 P2IN	6 P8IN	8 P32IN	10 OZ -	12 OA -	14 DB -	16 CZ	18 FG

<Cautions>

1. Check the stamped pin No. on the connector body while making a wiring.
2. For the function of each signal title or its symbol, refer to the wiring example of connector, CN I/F.
3. Check the stamped pin-No. on the Connector body while marking a wiring.

Interface cable

●MINAS A4

Cable of 2m is connected.

1) Part No. **DV0P4360**

2) Dimensions

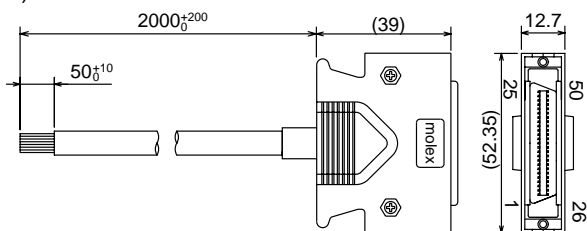

<Remarks>

Color designation of the cable
e.g.) Pin-1 Cable color : Orange
(Red1) : One red dot on the cable

3) Table for wiring

PIN No.	color	PIN No.	color	PIN No.	color	PIN No.	color	PIN No.	color
1	Orange (Red1)	11	Orange (Black2)	21	Orange (Red3)	31	Orange (Red4)	41	Orange (Red5)
2	Orange (Black1)	12	Yellow (Black1)	22	Orange (Black3)	32	Orange (Black4)	42	Orange (Black5)
3	Gray (Red1)	13	Gray (Red2)	23	Gray (Red3)	33	Gray (Red4)	43	Gray (Red5)
4	Gray (Black1)	14	Gray (Black2)	24	Gray (Black3)	34	White (Red4)	44	White (Red5)
5	White (Red1)	15	White (Red2)	25	White (Red3)	35	White (Black4)	45	White (Black5)
6	White (Black1)	16	Yellow (Red2)	26	White (Black3)	36	Yellow (Red4)	46	Yellow (Red5)
7	Yellow (Red1)	17	Yel(Blk2)/ Pink(Blk2)	27	Yellow (Red3)	37	Yellow (Black4)	47	Yellow (Black5)
8	Pink (Red1)	18	Pink (Red2)	28	Yellow (Black3)	38	Pink (Red4)	48	Pink (Red5)
9	Pink (Black1)	19	White (Black2)	29	Pink (Red3)	39	Pink (Black4)	49	Pink (Black5)
10	Orange (Red2)	20	—	30	Pink (Black3)	40	Gray (Black4)	50	Gray (Black5)

●MINAS A4P

1) Part No. **DV0P4510**

2) Dimensions

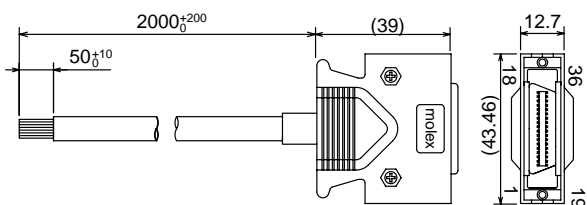

<Remarks>

Color designation of the cable
e.g.) Pin-1 Cable color : Orange
(Red1) : One red dot on the cable

3) Table for wiring

PIN No.	color	PIN No.	color	PIN No.	color
1	Orange(Red1)	13	Gray(Red2)	25	White(Red3)
2	Orange(Black1)	14	Gray(Black2)	26	White(Black3)
3	Gray(Red1)	15	White(Red2)	27	Yellow(Red3)
4	White(Red1)	16	White(Black2)	28	Yellow(Black3)
5	White(Black1)	17	Yellow(Red2)	29	Pink(Red3)
6	Gray(Black1)	18	Yellow(Black2)	30	Pink(Black3)
7	Yellow(Red1)	19	Pink(Red2)	31	Orange(Red4)
8	Yellow(Black1)	20	Pink(Black2)	32	Orange(Black4)
9	Pink(Red1)	21	Orange(Red3)	33	Gray(Red4)
10	Pink(Black1)	22	Orange(Black3)	34	Gray(Black4)
11	Orange(Red2)	23	Gray(Red3)	35	White(Red4)
12	Orange(Black2)	24	Gray(Black3)	36	White(Black4)

Communication cable (for connection with PC)

1) Part No. **DV0P1960**

2) Dimensions

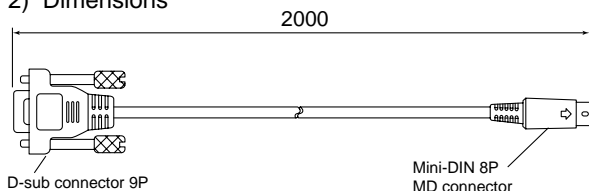

Communication cable (for RS485) <This cable cannot be used for the A4P series>

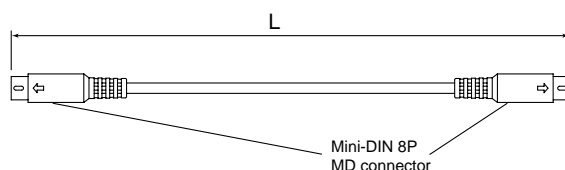

Part No.	L[mm]
DV0P1970	200
DV0P1971	500
DV0P1972	1000

- **Applicable motor models : MSMD 50W to 750W**
MQMA 100W to 400W
MAMA 100W to 750W [17-bit absolute] For brake, purchase our optional brake cable.

1) Part No. **DV0P4290**

2) Components

Title	Part No.	Number	Manufacturer	Note
Connector	55100-0600 or 55100-0670 (lead-free)	1	Molex Inc.	For CN X6 (6-pins)
Connector	172161-1	1	Tyco Electronics AMP	For junction cable to encoder (9-pins)
Connector pin	170365-1	9		
Connector	172159-1	1	Tyco Electronics AMP	For junction cable to motor (4-pins)
Connector pin	170366-1	4		

3) Pin configuration of connector, CN X6

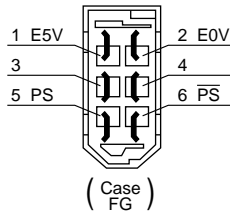

4) Pin configuration of junction cable for encoder

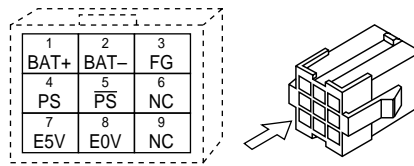

5) Pin configuration of junction cable for motor power

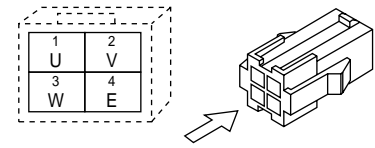

*When you connect the battery for absolute encoder, refer to A4-126,
 "When you make your own cable for 17-bit absolute encoder"

- **Applicable motor models : MSMD 50W to 750W**
MQMA 100W to 400W
MAMA 100W to 750W [2500P/r incremental encoder] For brake, purchase our optional brake cable.

1) Part No. **DV0P4380**

2) Components

Title	Part No.	Number	Manufacturer	Note
Connector	55100-0600 or 55100-0670 (lead-free)	1	Molex Inc.	For CN X6 (6-pins)
Connector	172160-1	1	Tyco Electronics AMP	For junction cable to encoder (6-pins)
Connector pin	170365-1	6		
Connector	172159-1	1	Tyco Electronics AMP	For junction cable to encoder (4-pins)
Connector pin	170366-1	4		

3) Pin configuration of connector, CN X6

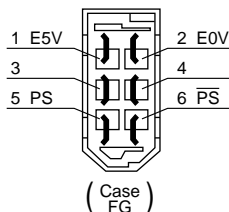

4) Pin configuration of junction cable for encoder

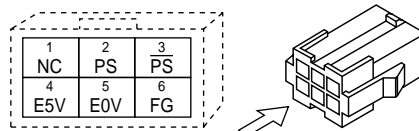

5) Pin configuration of junction cable for motor power

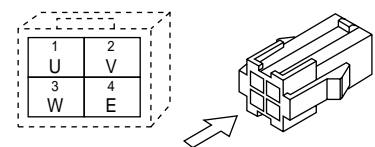

For DV0P2490, DV0P3480,
 • **recommended manual crimp tool**
 (to be prepared by customer)

Title	Part No.	Manufacturer
For junction cable to encoder	755330 - 1	Tyco Electronics AMP
For junction cable to motor	755331 - 1	

Options

- Applicable motor models : MSMA 1.0kW to 2.0kW
 MDMA 1.0kW to 2.0kW [17-bit absolute incremental encoder, 2500P/r incremental encoder] Without brake
 MHMA 500W to 1.5kW
 MGMA 900W

1) Part No. **DV0P4310**

2) Components

Title	Part No.	Number	Manufacturer	Note
Connector	55100-0600 or 55100-0670 (lead-free)	1	Molex Inc.	For CN X6 (6-pins)
Straight plug	N/MS3106B20-29S	1	Japan Aviation Electronics Industry Ltd.	For junction cable to encoder
Cable clamp	N/MS3057-12A	1	Japan Aviation Electronics Industry Ltd.	For junction cable to motor power
Straight plug	N/MS3106B20-4S	1	Japan Aviation Electronics Industry Ltd.	For junction cable to motor power
Cable clamp	N/MS3057-12A	1	Japan Aviation Electronics Industry Ltd.	For junction cable to motor power

- Applicable motor models : MSMA 3.0kW to 5.0kW
 MDMA 3.0kW to 5.0kW [17-bit absolute incremental encoder, 2500P/r incremental encoder] Without brake
 MHMA 2.0kW to 5.0kW
 MGMA 2.0kW to 4.5kW

1) Part No. **DV0P4320**

2) Components

Title	Part No.	Number	Manufacturer	Note
Connector	55100-0600 or 55100-0670 (lead-free)	1	Molex Inc.	For CN X6 (6-pins)
Straight plug	N/MS3106B-20-29S	1	Japan Aviation Electronics Industry Ltd.	For junction cable to encoder
Cable clamp	N/MS3057-12A	1	Japan Aviation Electronics Industry Ltd.	For junction cable to motor power
Straight plug	N/MS3106B22-22S	1	Japan Aviation Electronics Industry Ltd.	For junction cable to motor power
Cable clamp	N/MS3057-12A	1	Japan Aviation Electronics Industry Ltd.	For junction cable to motor power

- Applicable motor models : MSMA 1.0kW to 2.0kW
 MDMA 1.0kW to 2.0kW [17-bit absolute incremental encoder, 2500P/r incremental encoder] With brake
 MHMA 0.5kW to 1.5kW
 MGMA 900W

MFMA 0.4kW to 1.5kW [17-bit absolute incremental encoder, 2500P/r incremental encoder] Without brake
 With brake

1) Part No. **DV0P4330**

2) Components

Title	Part No.	Number	Manufacturer	Note
Connector	55100-0600 or 55100-0670 (lead-free)	1	Molex Inc.	For CN X6 (6-pins)
Straight plug	N/MS3106B20-29S	1	Japan Aviation Electronics Industry Ltd.	For junction cable to encoder
Cable clamp	N/MS3057-12A	1	Japan Aviation Electronics Industry Ltd.	For junction cable to motor power
Straight plug	N/MS3106B20-18S	1	Japan Aviation Electronics Industry Ltd.	For junction cable to motor power
Cable clamp	N/MS3057-12A	1	Japan Aviation Electronics Industry Ltd.	For junction cable to motor power

- Applicable motor models : MSMA 3.0kW to 5.0kW
 MDMA 3.0kW to 5.0kW [17-bit absolute incremental encoder, 2500P/r incremental encoder] With brake
 MHMA 2.0kW to 5.0kW
 MGMA 2.0kW to 4.5kW

MFMA 2.5kW to 4.5kW [17-bit absolute incremental encoder, 2500P/r incremental encoder] Without brake
 With brake

1) Part No. **DV0P4340**

2) Components

Title	Part No.	Number	Manufacturer	Note
Connector	55100-0600 or 55100-0670 (lead-free)	1	Molex Inc.	For CN X6 (6-pins)
Straight plug	N/MS3106B20-29S	1	Japan Aviation Electronics Industry Ltd.	For junction cable to encoder
Cable clamp	N/MS3057-12A	1	Japan Aviation Electronics Industry Ltd.	For junction cable to motor power
Straight plug	N/MS3106B24-11S	1	Japan Aviation Electronics Industry Ltd.	For junction cable to motor power
Cable clamp	N/MS3057-16A	1	Japan Aviation Electronics Industry Ltd.	For junction cable to motor power

•Applicable motor models : MDMA 7.5kW
 MGMA 6.0kW
 MHMA 7.5kW

[17-bit absolute incremental encoder,
 2500P/r incremental encoder] With brake

1) Part No. **DV0P3470**

2) Components

Title	Part No.	Number	Manufacturer	Note
Connector	55100-0600 or 55100-0670 (lead-free)	1	Molex Inc.	For CN X6 (6-pins)
Straight plug	N/MS3106B20-29S	1	Japan Aviation Electronics Industry Ltd.	For junction cable to encoder
Cable clamp	N/MS3057-12A	1		
Straight plug	N/MS3106B32-17S	1	Japan Aviation Electronics Industry Ltd.	For junction cable to motor power
Cable clamp	N/MS3057-20A	1		

•Applicable motor models : MDMA 7.5kW
 MGMA 6.0kW
 MHMA 7.5kW

[17-bit absolute incremental encoder,
 2500P/r incremental encoder] Without brake

1) Part No. **DV0P3480**

2) Components

Title	Part No.	Number	Manufacturer	Note
Connector	55100-0600 or 55100-0670 (lead-free)	1	Molex Inc.	For CN X6 (6-pins)
Straight plug	N/MS3106B20-29S	1	Japan Aviation Electronics Industry Ltd.	For junction cable to encoder
Cable clamp	N/MS3057-12A	1		
Straight plug	N/MS3106B32-17S	1	Japan Aviation Electronics Industry Ltd.	For junction cable to motor power
Cable clamp	N/MS3057-20A	1		
Straight plug	N/MS3106B14S-2S	1	Japan Aviation Electronics Industry Ltd.	For junction cable to brake cable
Cable clamp	N/MS3057-6A	1		

Options

Setup support software "PANATERM[®]"

- 1) Part No. **DV0P4460** (Japanese/English version)
- 2) Supply media : CD-ROM

<Caution>

For setup circumstance, refer to the Instruction Manual of "PANATERM[®]".

Mounting bracket

Frame symbol of applicable driver	part No.	Mounting screw	Dimensions	
			Upper side	Bottom side
Frame A	DV0P4271	M4 x L6 Pan head 4pcs		
Frame B	DV0P4272	M4 x L6 Pan head 4pcs		
Frame C	DV0P4273	M4 x L6 Pan head 4pcs		
Frame D	DV0P4274	M4 x L6 Pan head 4pcs		

<Caution> For Frame E, F you can make a front end and back end mounting by changing the mounting direction of L-shape bracket (attachment).

Console

1) Part No. **DV0P4420** Caution) An existing console(DV0P3690) cannot be used for the A4P series.

2) Dimensions

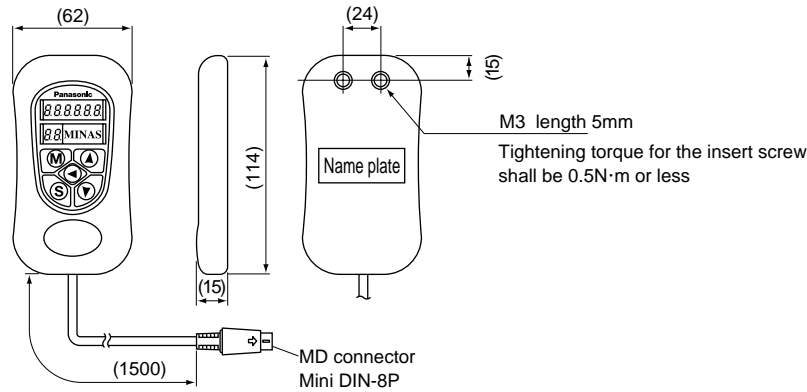

Reactor

Fig.1

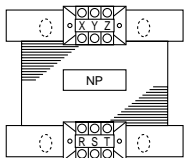
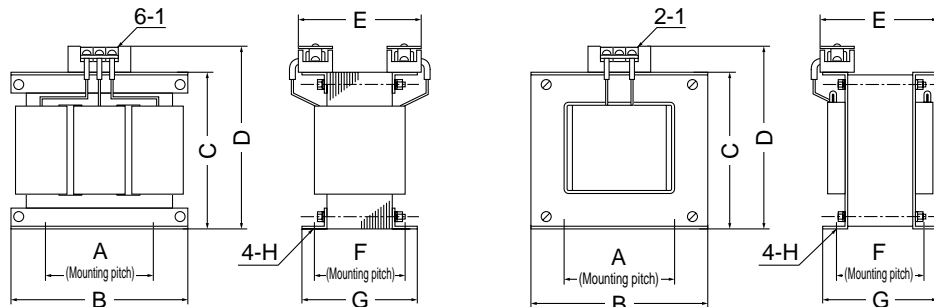

Fig.2



	Part No.	A	B	C	D	E	F	G	H	I	Inductance (mH)	Rated current (A)
Fig. 1	DV0P220	65	125	83	118	145	70	85	7 (width) x 12 (length)	M4	6.81	3
	DV0P221	60	150	113	137	120	60	75	7 (width) x 12 (length)	M4	4.02	5
	DV0P222	60	150	113	137	130	70	95	7 (width) x 12 (length)	M4	2	8
	DV0P223	60	150	113	137	140	79	95	7 (width) x 12 (length)	M4	1.39	11
	DV0P224	60	150	113	137	145	84	100	7 (width) x 12 (length)	M4	0.848	16
	DV0P225	60	150	113	137	160	100	115	7 (width) x 12 (length)	M5	0.557	25
Fig. 2	DV0P226	55	80	68	90	90	41	55	φ 7	M4	6.81	3
	DV0P227	55	80	68	90	90	41	55	φ 7	M4	4.02	5
	DV0P228	55	80	68	90	95	46	60	φ 7	M4	2	8

• Harmonic restraint on general-purpose inverter and servo driver

On September, 1994, Guidelines for harmonic restraint on heavy consumers who receive power through high voltage system or extra high voltage system and Guidelines for harmonic restraint on household electrical appliances and general-purpose articles established by the Agency for Natural Resources and Energy of the Ministry of Economy, Trade and Industry (the ex-Ministry of International Trade and Industry). According to those guidelines, the Japan Electrical Manufacturers Association (JEMA) have prepared technical documents (procedure to execute harmonic restraint: JEM-TR 198, JEM-TR 199 and JEM-TR 201) and have been requesting the users to understand the restraint and to cooperate with us. On January, 2004, it has been decided to exclude the general-purpose inverter and servo driver from the Guidelines for harmonic restraint on household electrical appliances and general-purpose articles". After that, the Guidelines for harmonic restraint on household electrical appliances and general-purpose articles was abolished on September 6, 2004.

We are pleased to inform you that the procedure to execute the harmonic restraint on general-purpose inverter and servo driver will be modified as follows.

1. All types of the general-purpose inverters and servo drivers used by specific users are under the control of the Guidelines for harmonic restraint on heavy consumers who receive power through high voltage system or extra high voltage system". The users who are required to apply the guidelines must calculate the equivalent capacity and harmonic current according to the guidelines and must take appropriate countermeasures if the harmonic current exceeds a limit value specified in a contract demand. (Refer to JEM-TR 210 and JEM-TR 225.)
2. The Guidelines for harmonic restraint on household electrical appliances and general-purpose articles was abolished on September 6, 2004. However, based on conventional guidelines, JEMA applies the technical documents JEM-TR 226 and JEM-TR 227 to any users who do not fit into the Guidelines for harmonic restraint on heavy consumers who receive power through high voltage system or extra high voltage system from a perspective on enlightenment on general harmonic restraint. The purpose of these guidelines is the execution of harmonic restraint at every device by a user as usual to the utmost extent.

Options

External regenerative resistor

Part No.	Manufacturer's part No.	Specifications					Activation temperature of built-in thermostat
		Resistance	Free air	Reted power (reference)*			
				with fan[W]			
1m/s	2m/s	3m/s					
DV0P4280	RF70M	50 Ω	10W	25	35	45	140±5°C B-contact Open/Close capacity (resistance load) 4A 125VAC 10000 times 2.5A 250VAC 10000 times
DV0P4281	RF70M	100 Ω	10W	25	35	45	
DV0P4282	RF180B	25 Ω	17W	50	60	75	
DV0P4283	RF180B	50 Ω	17W	50	60	75	
DV0P4284	RF240	30 Ω	40W	100	120	150	
DV0P4285	RH450F	20 Ω	52W	130	160	200	

*Power with which the driver can be used without activating the built-in thermostat.
Manufacturer : Iwaki Musen Kenkyusho

DV0P4280, DV0P4281

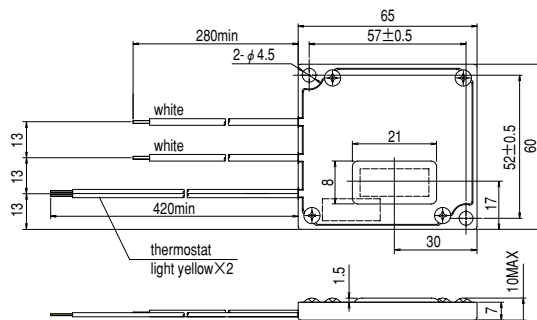

DV0P4282, DV0P4283

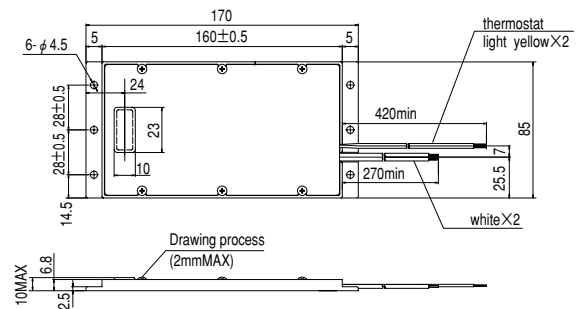

DV0P4284

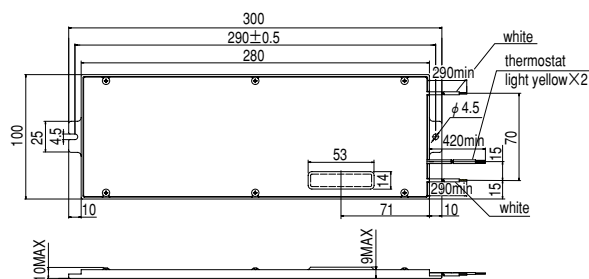

DV0P4285

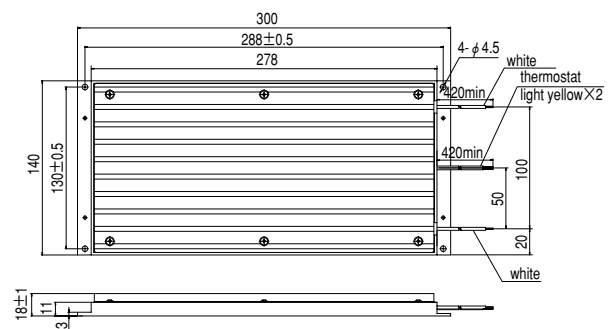

<Remarks>

Thermal fuse and thermostat are installed for safety. Compose the circuit so that the power will be turned off when the thermostat is activated. The thermal fuse may blow due to heat dissipating condition, working temperature, supply voltage or load fluctuation.

Make it sure that the surface temperature of the resistor may not exceed 100°C at the worst running conditions with the machine, which brings large regeneration (such case as high supply voltage, load inertia is large or deceleration time is short) Install a fan for a forced cooling if necessary.

<Caution>

Regenerative resistor gets very hot.

Take preventive measures for fire and burns.
Avoid the installation near inflammable objects,
and easily accessible place by hand.

Battery for absolute encoder

Battery (Frame A to G)

- 1) Part No. **DV0P2990**
- 2) Lithium battery by Toshiba Battery Co.
ER6V, 3.6V 2000mAh

<Caution>

This battery is categorized as hazardous substance, and you may be required to present an application of hazardous substance when you transport by air (both passenger and cargo airlines).

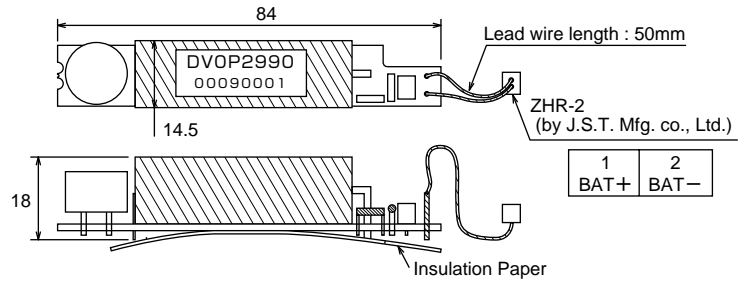

When you make your own cable for 17-bit absolute encoder

When you make your own cable for 17-bit absolute encoder, connect the optional battery for absolute encoder, DV0P2990 as per the wiring diagram below. Connector of the battery for absolute encoder to be provided by customer.

<Cautions>

Install and fix the battery securely. If the installation and fixing of the battery is not appropriate, it may cause the wire breakdown or damage of the battery.

Refer to the instruction manual of the battery for handling of the battery.

■ where to install the battery

- (1) indoors, where the products are not subjected to rain or direct sun beam
- (2) where the products are not subjected to corrosive atmospheres such as hydrogen sulfide, sulfurous acid, chlorine, ammonia, chloric gas, acid, alkaline, salt and so on, and free from splash of inflammable gas, grinding oil, oil mist, iron powder or chips and etc.
- (3) well-ventilated and humid and dust free place
- (4) vibration-free place

Wiring Diagram

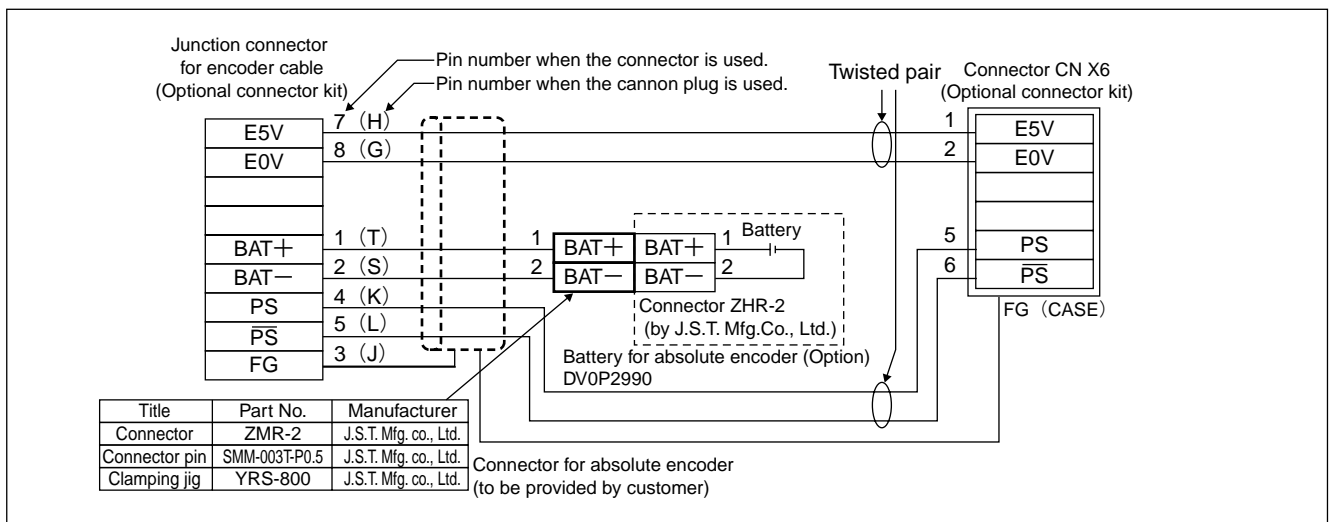

<Precautions in using options>

Use options correctly after reading operation manuals of the options to better understand the precautions.

Take care not to apply excessive stress to each optional part.

Recommended components

Surge absorber for motor brake

Motor	Surge absorber for motor brake
MSMD 50W - 750W	Z15D271 Ishizuka Electronics Co.
MAMA 100W - 750W	Z15D151 Ishizuka Electronics Co.
MHMA 2.0kW - 7.5kW	
MGMA 900W - 2.0kW	
MSMA 1.0kW - 5.0kW	
MDMA 4.0kW - 7.5kW	
MFMA 1.5kW	
MGMA 3.0kW - 6.0kW	
MDMA 1.0kW - 3.0kW	TNR9V820K Nippon Chemi_Con Co.
MFMA 400W	
MFMA 2.5kW - 4.5kW	
MHMA 500W - 1.5kW	

List of Manufactures for peripheral equipments

(reference only)

Peripheral components	Manufacturer	Tel No./Home Page
Non-fuse breaker Magnetic contactor Surge absorber	Automation Controls Company Matsushita Electric Works, Ltd.	81-6-6908-1131 http://www.mew.co.jp
Regenerative resistor	Iwaki Musen Kenkyusho Co., Ltd.	81-44-833-4311 http://www.iwakimusen.co.jp/
Surge absorber for holding brake	Nippon Chemi_Con Corp.	81-3-5436-7608 http://www.chemi_con.co.jp/
	Ishizuka Electronics Corp.	81-3-3621-2703 http://www.semitec.co.jp/
Noise filter for signal lines	TDK Corp.	81-3-5201-7229 http://www.tdk.co.jp/
Surge absorber/Noise filter	Okaya Electric Industries Co. Ltd.	81-3-4544-7030 http://www.okayatec.co.jp/
Connector	Japan Aviation Electronics Industry, Ltd.	81-3-3780-2717 http://www.jae.co.jp
	Sumitomo 3M	81-3-5716-7290 http://www.mmmco.jp
	Tyco Electronics AMP k.k,	81-44-844-8111 http://www.tycoelectronics.com/japan/amp
	Japan Molex Inc.	81-462-65-2313 http://www.molex.co.jp
	Hirose Electric Co., Ltd.	81-3-3492-2161 http://www.hirose.co.jp/
	J.S.T. Mfg. Co., Ltd.	81-45-543-1271 http://www.jst-mfg.com/index_i.html
Cable	Daiden Co., Ltd.	81-3-5805-5880 http://www.dyden.co.jp/
Linear scale	Mitutoyo Corp.	81-44-813-5410 http://www.mitutoyo.co.jp

* The above list is for reference only. We may change the manufacturer without notice.

Information

Index

Motor capacity selection software	F2
Option selection software	F3
Setup support software	F4
Guide to the International System of Units (SI)	F5
Selecting Motor Capacity	F7
Request Sheet for Motor Selection	F13
Connection between driver and controller	F21
Index	F31
Sales Office	F49

Motor capacity selection software

AC servo motor capacity selection software

We have prepared PC software "M-SELECT" for AC servo motor capacity selection. Consult our sales representative or authorized distributor.

Example of capacity calculation screen

Parameter	Value	Unit
Ball screw density	Ball screw horizontal	
Lead of the ball screw	10 mm	mm
Diameter of the ball screw	10 mm	mm
Length of the ball screw	500 mm	mm
Mass of the table	0 kg	kg
Transmission efficiency	0.9	
Coefficient of friction	0.1	
Remarks		
Ball screw inertia	0.0390 kg-cm ²	

Parameter	Value	Unit
Ball screw density	Ball screw vertical	
Lead of the ball screw	10 mm	mm
Diameter of the ball screw	10 mm	mm
Length of the ball screw	500 mm	mm
Mass of the table	0 kg	kg
Transmission efficiency	0.9	
Coefficient of friction	0.1	
Remarks		
Ball screw inertia	0.0390 kg-cm ²	

Parameter	Value	Unit
Table density	Index table	
Outside diameter of the table	0 mm	mm
Thickness of the table	0 mm	mm
Diameter of the table support	0 mm	mm
Coefficient of friction	0.1	
Outside diameter of the work load	0 mm	mm
Mass of the work load	0 kg	kg
Positional eccentricity of the work load	0 mm	mm
Number of work loads	1 Piece	
Remarks		
Mass of the table	0.8800 kg	
Table inertia	0.8800 kg-cm ²	
Work inertia (single)	0.8800 kg-cm ²	
Work inertia (including eccentricity)	0.8800 kg-cm ²	

Parameter	Value	Unit
Drive pulley density	Ball conveyor horizontal	
Drive pulley density	79 g/cm ³	g/cm ³
Diameter of the drive pulley	40 mm	mm
Thickness of the drive pulley	20 mm	mm
Diameter of the drive pulley	40 mm	mm
Thickness of the drive pulley	20 mm	mm
Mass of the table	0 kg	kg
Mass of the ball	0 kg	kg
Transmission efficiency	0.9	
Coefficient of friction	0.1	
Remarks		
Height of the drive pulley	0.1960 kg	
Drive pulley inertia	0.3971 kg-cm ²	
Height of the drive pulley	0.1960 kg	

Elapsed time	Time interval	Rotational speed	Loading rate	Abs. position	Acc. time	Dec. time	Acceleration
1	0.0000	0.0000	0.0000	0.0000	0.0000	0.0000	0.0000
2	2.0000	2000.0000	200.0000	588.8000	0.0000	0.0000	0.0000
3	3.0000	1.0000	0.0000	588.8000	0.0000	0.0000	0.0000
4	5.0000	2.0000	-200.0000	-0.0000	0.0000	0.0000	-0.0000

Rating	Unit	Criteria	Unit	Result	Unit	Remarks	Unit	Judgment
Motor inertia ratio	kg-cm ²	≤ 0.0800	times or less	1.0800	kg-cm ²	3.8728	times	OK
Motor rotation speed	r/min	≤ 3000.0000	r/min or less	2000.0000	r/min	66.6667	%	OK
Motor torque	kg	≤ 0.8800	kg or less	0.4714	kg	36.2047	%	OK
Transline torque	kg	≤ 0.8800	kg or less	0.5720	kg	44.0219	%	OK
Maximum torque	kg	≤ 0.8800	kg or less	0.6260	kg	56.4719	%	OK
Stop holding torque	N	≤ 0.8800	N or less	0.4214	N	32.4152	%	OK
Resistor load factor	%	≤ 0.8800	% or less	16.3624	%	Not built-in	%	following selection

Option selection software

Option selection software for AC servo motor MINAS series

We have prepared PC software to enable fast, easy, and correct option selection, a complicated job without the software.

Option Selection Method

Selection based on series and type

- Options are selected by motor series and type based on motor specifications such as motor output and power requirements.

Direct selection based on a part number of motor and driver

- Options can be selected directly based on a part number of motor and driver if it is already determined.



Part Number Search Function

One-shot search for a part number of motor and driver

- One-shot search is possible to search for a part number of motor and driver based on motor specifications such as motor output, power used, presence of brake and gear, and encoder type.

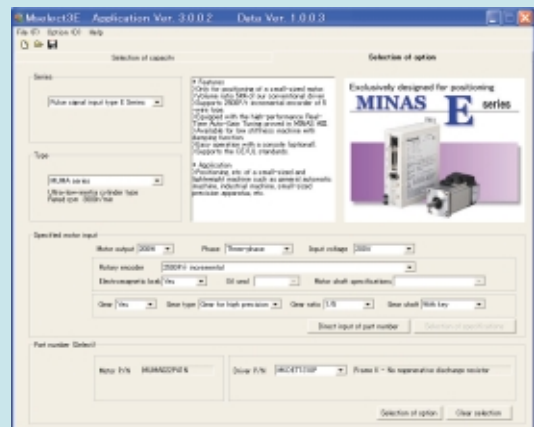

Display of All Dedicated Options

Total elimination of incorrect selection

- Only necessary options can be selected without fail.

Storage of selection results

- Selection results can be printed and stored with comments.

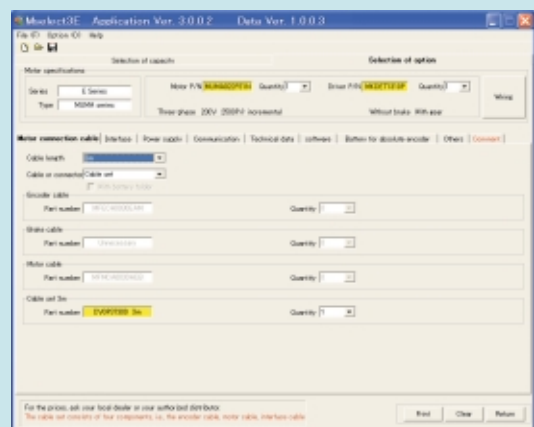

Setup support software

Setup support software PANATERM® for MINAS series AC servo motor & Driver

The PANATERM® assists users in setting parameters, monitoring control conditions, setup support, and analyzing mechanical operation data on the PC screen, when installed in a commercially available personal computer, and connected to the MINAS series through the RS232 serial interface.

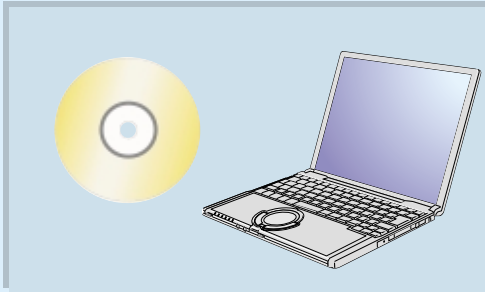

Basic function

Parameter setup

- After a parameter is defined on the screen, it will be sent to the driver immediately.
- Once you register parameters you frequently use, they can be easily set up on the screen.

Monitoring control conditions

Monitor

- Control conditions: Control mode, velocity, torque, error and warning
- Driver input signal
- Load conditions: Total count of command/feedback pulses, Load ratio, Regenerative resistor load ratio

Alarm

- Displays the numbers and contents of the current alarm and up to 14 error events in the past.
- Clears the numbers and contents of the current alarm and up to 14 error events in the past.

Setup

Auto tuning

- Gain adjustment and inertia ratio measurement

Graphic waveform display

- The graphic display shows command velocity, actual velocity, torque, and error waveforms.

Absolute encoder setup

- Clears absolute encoder at the origin.
- Displays single revolution/multi-revolution data.
- Displays absolute encoder status.

Analysis of mechanical operation data

Frequency analysis

- Measures frequency characteristics of the machine, and displays Bode diagram.

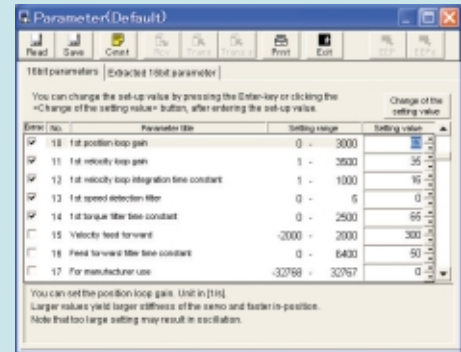

Parameter

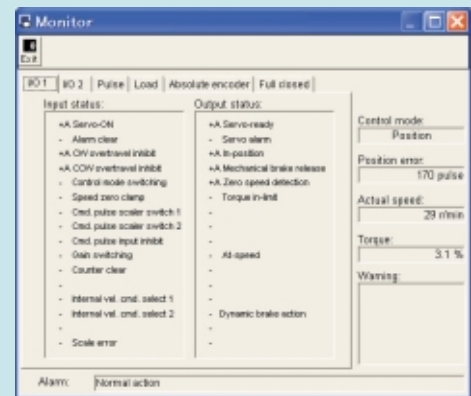

Monitor

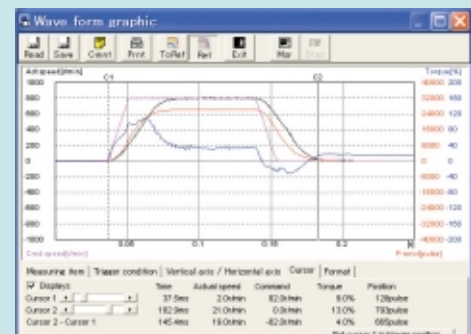

Graphic waveform display

Guide to the International System of Units (SI)

Organization of the system of units

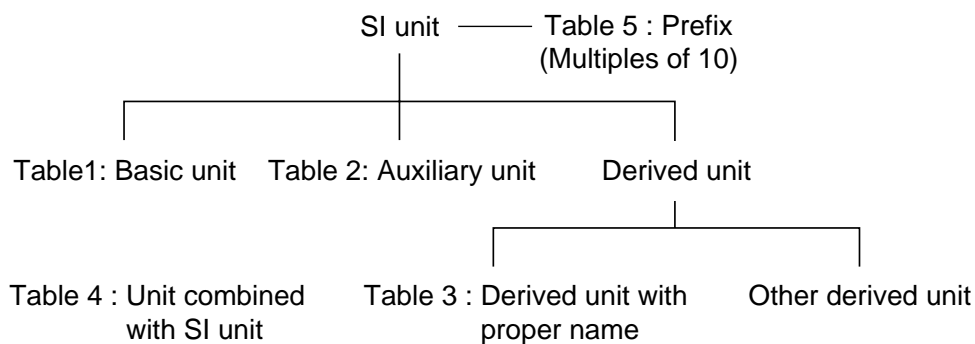

Table 1: Basic unit

Quantity	Name of unit	Symbol of unit
Length	meter	m
Weight	kilogram	kg
Time	second	s
Current	ampere	A
Thermodynamic temperature	kelvin	K
Amount of substance	mol	mol
Luminous intensity	candela	cd

Table 2: Auxiliary unit

Quantity	Name of unit	Symbol of unit
Plane angle	radian	rad
Solid angle	steradian	sr

Table 3: Major derived unit with proper name

Quantity	Name	Symbol of unit	Derivation from basic unit, auxiliary unit or other derived unit
Frequency	hertz	Hz	1Hz=1s ⁻¹
Force	newton	N	1N=1kg·m/s ²
Pressure, Stress	pascal	Pa	1Pa=1N/m ²
Energy, Work, Amount of heat	joule	J	1J=1N·m
Amount of work, Work efficiency, Power, Electric power	watt	W	1W=1J/s
Electric charge, Amount of electricity	coulomb	C	1C=1A·s
Electric potential, Potential difference, Voltage, Electromotive force	volt	V	1V=1J/C
Electrostatic capacity, Capacitance	farad	F	1F=1C/V
Electric resistance	ohm	Ω	1Ω=1V/A
Electric conductance	siemens	S	1S=1Ω ⁻¹
Magnetic flux	weber	Wb	1Wb=1V·s
Magnetic flux density, Magnetic induction	tesla	T	1T=1Wb/m ²
Inductance	henry	H	1H=1Wb/A
Degree centigrade (Celsius)	degree centigrade (Celsius) / degree	°C	t°C=(t+273.15)K
Luminous flux	lumen	lm	1lm=1cd·sr
Illuminance	lux	lx	1lx=1lm/m ²

Table 4: Unit combined with SI unit

Quantity	Name	Symbol of unit
Time	minute	min
	hour	h
	day	d
Plane angle	degree	°
	minute	'
	second	"
Volume	liter	l, L
Weight	ton	t

Table 5: Prefix

Multiples powered to unit	Prefix	
	Name	Symbol
10 ¹⁸	exa	E
10 ¹⁵	peta	P
10 ¹²	tera	T
10 ⁹	giga	G
10 ⁶	mega	M
10 ³	kilo	k
10 ²	hecto	h
10	deca	da
10 ⁻¹	deci	d
10 ⁻²	centi	c
10 ⁻³	milli	m
10 ⁻⁶	micro	μ
10 ⁻⁹	nano	n
10 ⁻¹²	pico	p
10 ⁻¹⁵	femto	f
10 ⁻¹⁸	atto	a

Major compatible unit

Quantity	Symbol of conventional unit	Symbol of SI unit and compatible unit	Conversion value
Length	μ (micron)	μ m	$1\mu=1\mu\text{m}$ (micrometer)
Acceleration	Gal	m/s^2	$1\text{Gal}=10^{-2}\text{m/s}^2$
	G	m/s^2	$1\text{G}=9.80665\text{m/s}^2$
Frequency	c/s, c	Hz	$1\text{c/s}=\text{Hz}$
Revolving speed, Number of revolutions	rpm	s^{-1} or min^{-1} , r/min	$1\text{rpm}=1\text{min}^{-1}$
Weight	kgf	–	} Same value
Mass	–	kg	
Weight flow rate	kgf/s	–	} Same value
Mass flow rate	–	kg/s	
Specific weight	kgf/m ³	–	} Same value
Density	–	kg/m ³	
Specific volume	m ³ /kgf	m ³ /kg	Same value
Load	kgf	N	$1\text{kgf}=9.80665\text{N}$
Force	kgf	N	$1\text{kgf}=9.80665\text{N}$
	dyn	N	$1\text{dyn}=10^{-3}\text{N}$
Moment of force	kgf·m	N·m	$1\text{kgf}\cdot\text{m}=9.80665\text{N}\cdot\text{m}$
Pressure	kgf/cm ²	Pa, bar ⁽²⁾ or kgf/cm ²	$1\text{kgf/cm}^2=9.80665 \times 10^4\text{Pa}=0.980665\text{bar}$
	at (Engineering atmospheric pressure)	Pa	$1\text{at}=9.80665 \times 10^4\text{Pa}$
	atm (Atmospheric pressure)	Pa	$1\text{atm}=1.01325 \times 10^5\text{Pa}$
	mH ₂ O, mAq	Pa	$1\text{mH}_2\text{O}=9.80665 \times 10^3\text{Pa}$
	mmHg	Pa or mmHg ⁽²⁾	$1\text{mmHg}=133.322\text{Pa}$
Stress	kgf/mm ²	Pa or N/m ²	$1\text{kgf/mm}^2=9.80665 \times 10^4\text{Pa}$ $=9.80665 \times 10^6\text{N/m}^2$
	kgf/cm ²	Pa or N/m ²	$1\text{kgf/cm}^2=9.80665 \times 10^4\text{Pa}$ $=9.80665 \times 10^4\text{N/m}^2$
Elastic modulus	kgf/m ²	Pa or N/m ²	$1\text{kgf/m}^2=9.80665\text{Pa}=9.80665\text{N/m}^2$ $1\text{kgf/cm}^2=9.80665 \times 10^4\text{N/m}^2$
	kgf·m	J (joule)	$1\text{kgf}\cdot\text{m}=9.80665\text{J}$
Energy, Work	erg	J	$1\text{erg}=10^{-7}\text{J}$
	kgf·m/s	W (watt)	$1\text{kgf}\cdot\text{m/s}=9.80665\text{W}$
Work efficiency, Power	PS	W	$1\text{PS}=0.7355\text{kW}$
	PP	Ps·s	$1\text{P}=0.1\text{Pa}\cdot\text{s}$
Viscosity	PP	Ps·s	$1\text{P}=0.1\text{Pa}\cdot\text{s}$
Kinetic viscosity	St	mm ² /s	$10^{-2}\text{St}=1\text{mm}^2/\text{s}$
Thermodynamic temperature	K	K (kelvin)	$1\text{K}=1\text{K}$
Temperature interval	deg	K ⁽³⁾	$1\text{deg}=1\text{K}$
Amount of heat	cal	J	$1\text{cal}=4.1868\text{J}$
Heat capacity	cal/°C	J/K ⁽³⁾	$1\text{cal}/^\circ\text{C}=4.1868\text{J/K}$
Specific heat, Specific heat capacity	cal/(kgf·°C)	cal/(kgf·K) ⁽³⁾	$1\text{cal}/(\text{kgf}\cdot^\circ\text{C})=4.1868\text{J}/(\text{kg}\cdot\text{K})$
Entropy	cal/K	J/K	$1\text{cal/K}=4.1868\text{J/K}$
Specific entropy	cal/(kgf·K)	J/(kg·K)	$1\text{cal}/(\text{kgf}\cdot\text{K})=4.1868\text{J}/(\text{kg}\cdot\text{K})$
Internal energy (Enthalpy)	cal	J	$1\text{cal}=4.1868\text{J}$
Specific internal energy (Specific enthalpy)	cal/kgf	J/kg	$1\text{cal}/\text{kgf}=4.1868\text{J}/\text{kg}$
Heat flux	cal/h	W	$1\text{kcal}/\text{h}=1.16279\text{W}$
Heat flux density	cal/(h·m ²)	W/m ²	$1\text{kcal}/(\text{h}\cdot\text{m}^2)=1.16279\text{W}/\text{m}^2$
Thermal conductivity	cal/(h·m·°C)	W/(m·K) ⁽³⁾	$1\text{kcal}/(\text{h}\cdot\text{m}\cdot^\circ\text{C})=1.16279\text{W}/(\text{m}\cdot\text{K})$
Coefficient of thermal conductivity	cal/(h·m ² ·°C)	W/(m ² ·K) ⁽³⁾	$1\text{kcal}/(\text{h}\cdot\text{m}^2\cdot^\circ\text{C})=1.16279\text{W}/(\text{m}^2\cdot\text{K})$
Intensity of magnetic field	Oe	A/m	$1\text{Oe}=10^2/(4\pi)\text{A}/\text{m}$
Magnetic flux	Mx	Wb (weber)	$1\text{Mx}=10^{-3}\text{Wb}$
Magnetic flux density	Gs, G	T (tesla)	$1\text{Gs}=10^{-4}\text{T}$

Note

- (1) Applicable to liquid pressure. Also applicable to atmospheric pressure of meteorological data, when "bar" is used in international standard.
 (2) Applicable to scale or indication of blood pressure manometers.
 (3) "°C" can be substituted for "K".

Selecting Motor Capacity

Flow of motor selection

1. Definition of mechanism to be driven by motor.

Define details of individual mechanical components (ball screw length, lead and pulley diameters, etc.)

<Typical mechanism>

Ball screw mechanism

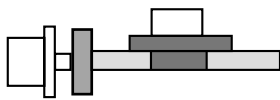

Belt mechanism

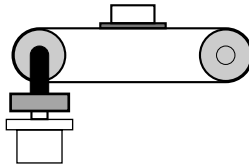

Rack & pinion, etc.

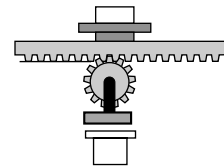

2. Definition of operating pattern.

Acceleration/deceleration time, Constant-velocity time, Stop time, Cycle time, Travel distance

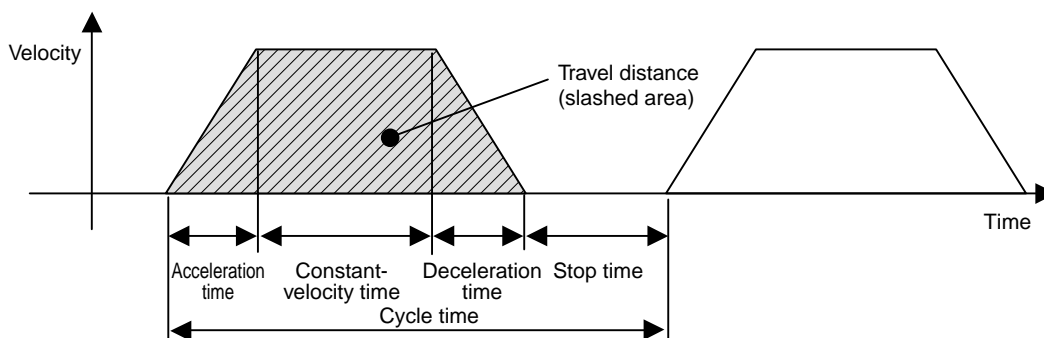

Note) Selection of motor capacity significantly varies depending on the operating pattern.

The motor capacity can be reduced if the acceleration/deceleration time and stop time are set as long as possible.

3. Calculation of load inertia and inertia ratio.

Calculate load inertia for each mechanical component. (Refer to "General inertia calculation method" described later.)

Divide the calculated load inertia by the inertia of the selected motor to check the inertia ratio.

For calculation of the inertia ratio, note that the catalog value of the motor inertia is expressed as " $\times 10^{-4}\text{kg}\cdot\text{m}^2$ ".

4. Calculation of motor velocity

Calculate the motor velocity from the moving distance, acceleration / deceleration time and constant-velocity time.

5. Calculation of torque

Calculate the required motor torque from the load inertia, acceleration/deceleration time and constant-velocity time.

6. Calculation of motor

Select a motor that meets the above 3 to 5 requirements.

Description on the items related to motor selection

1. Torque

(1) Peak torque

Indicate the maximum torque that the motor requires during operation (mainly in acceleration and deceleration steps). The reference value is 80% or less of the maximum motor torque. If the torque is a negative value, a regenerative discharge resistor may be required.

(2) Traveling torque, Stop holding torque

Indicates the torque that the motor requires for a long time. The reference value is 80% or less of the rated motor torque. If the torque is a negative value, a regenerative discharge resistor may be required.

Traveling torque calculation formula for each mechanism

Ball screw mechanism

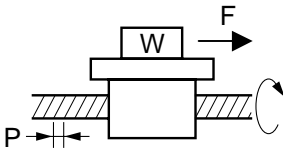

Traveling torque $T_f = \frac{P}{2\pi\eta} (\mu gW + F)$

W : Weight [kg]

P : Lead [m]

F : External force [N]

η : Mechanical efficiency

μ : Coefficient of friction

g : Acceleration of gravity 9.8[m/s²]

Belt mechanism

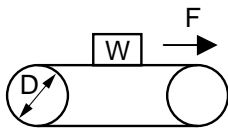

Traveling torque $T_f = \frac{D}{2\pi\eta} (\mu gW + F)$

W : Weight [kg]

P : Pulley diameter [m]

F : External force [N]

η : Mechanical efficiency

μ : Coefficient of friction

g : Acceleration of gravity 9.8[m/s²]

(3) Effective torque

Indicates a root-mean-square value of the total torque required for running and stopping the motor per unit time. The reference value is approx. 80% or less of the rated motor torque.

$$T_{rms} = \sqrt{\frac{T_a^2 \times t_a + T_f^2 \times t_b + T_d^2 \times t_d}{t_c}}$$

T_a : Acceleration torque [N·m]

T_f : Traveling torque [N·m]

T_d : Deceleration torque [N·m]

t_a : Acceleration time [s]

t_b : Constant-velocity time [s]

t_d : Deceleration time [s]

t_c : Cycle time [s]

(Run time + Stop time)

2. Motor velocity

Maximum velocity

Maximum velocity of motor in operation: The reference value is the rated velocity or lower value.

When the motor runs at the maximum velocity, you must pay attention to the motor torque and temperature rise.

For actual calculation of motor velocity, see "Example of motor selection" described later.

Selecting Motor Capacity

3. Inertia and inertia ratio

Inertia is like the force to retain the current moving condition.

Inertia ratio is calculated by dividing load inertia by rotor inertia.

Generally, for motors with 750 W or lower capacity, the inertia ratio should be "20" or less. For motors with 1000 W or higher capacity, the inertia ratio should be "10" or less.

If you need quicker response, a lower inertia ratio is required.

(For example, when the motor takes several seconds in acceleration step, the inertia ratio can be further increased.)

General inertia calculation method

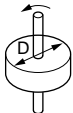
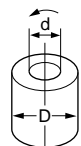
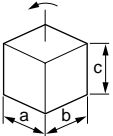
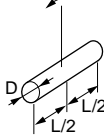
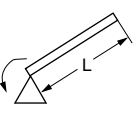
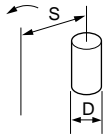
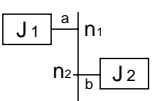
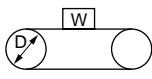
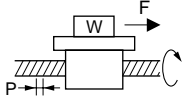
Shape	J calculation formula	Shape	J calculation formula
Disk 	$J = \frac{1}{8} W D^2 \text{ [kg}\cdot\text{m}^2]$ <p>W : Weight [kg] D : Outer diameter [m]</p>	Hollow cylinder 	$J = \frac{1}{8} W (D^2 + d^2) \text{ [kg}\cdot\text{m}^2]$ <p>W : Weight [kg] D : Outer diameter [m] d : Inner diameter [m]</p>
Prism 	$J = \frac{1}{12} W D (a^2 + b^2) \text{ [kg}\cdot\text{m}^2]$ <p>W : Weight [kg] a, b, c : Side length [m]</p>	Uniform rod 	$J = \frac{1}{48} W (3D^2 + 4L^2) \text{ [kg}\cdot\text{m}^2]$ <p>W : Weight [kg] D : Outer diameter [m] L : Length [m]</p>
Straight rod 	$J = \frac{1}{3} W L^2 \text{ [kg}\cdot\text{m}^2]$ <p>W : Weight [kg] L : Length [m]</p>	Separated rod 	$J = \frac{1}{8} W D^2 + W S^2 \text{ [kg}\cdot\text{m}^2]$ <p>W : Weight [kg] D : Outer diameter [m] S : Distance [m]</p>
Reduction gear 	<p>Inertia on shaft "a"</p> $J = J_1 + \left(\frac{n_2}{n_1}\right)^2 J_2 \text{ [kg}\cdot\text{m}^2]$ <p>n_1 : A rotational speed of a shaft [r/min] n_2 : A rotational speed of b shaft [r/min]</p>		
Conveyor 	$J = \frac{1}{4} W D^2 \text{ [kg}\cdot\text{m}^2]$ <p>W : Workpiece weight on conveyor [kg] D : Drum diameter [m]</p> <p>* Excluding drum J</p>	Ball screw 	$J = J_B + \frac{W \cdot P^2}{4\pi^2} \text{ [kg}\cdot\text{m}^2]$ <p>W : Weight [kg] P : Lead JB : J of ball screw</p>

If weight (W [kg]) is unknown, calculate it with the following formula:

$$\text{Weight } W[\text{kg}] = \text{Density } \rho[\text{kg}/\text{m}^3] \times \text{Volume } V[\text{m}^3]$$

Density of each material

Iron $\rho = 7.9 \times 10^3 \text{ [kg}/\text{m}^3]$

Aluminum $\rho = 2.8 \times 10^3 \text{ [kg}/\text{m}^3]$

Brass $\rho = 8.5 \times 10^3 \text{ [kg}/\text{m}^3]$

To drive ball screw mechanism

1. Example of motor selection for driving ball screw mechanism

Workpiece weight	WA = 10 [kg]
Ball screw length	BL = 0.5 [m]
Ball screw diameter	BD = 0.02 [m]
Ball screw pitch	BP = 0.02 [m]
Ball screw efficiency	Bη = 0.9
Travel distance	0.3 [m]
Coupling inertia	Jc = 10 × 10 ⁻⁶ [kg·m ²] (Use manufacturer-specified catalog value, or calculation value.)

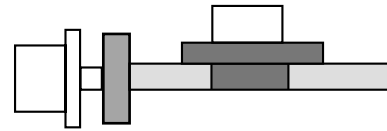

2. Running pattern :

Acceleration time	ta = 0.1 [s]
Constant-velocity time	tb = 0.8 [s]
Deceleration time	td = 0.1 [s]
Cycle time	tc = 2 [s]
Travel distance	0.3 [m]

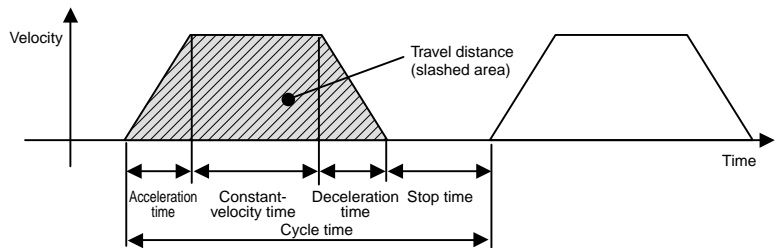

3. Ball screw weight

$$BW = \rho \times \pi \times \left(\frac{BD}{2}\right)^2 \times BL = 7.9 \times 10^3 \times \pi \times \left(\frac{0.02}{2}\right)^2 \times 0.5$$

$$= 1.24 \text{ [kg]}$$

4. Load inertia

$$JL = Jc + JB = Jc + \frac{1}{8} BW \times BD^2 + \frac{WA \cdot BP^2}{4\pi^2}$$

$$= 0.00001 + (1.24 \times 0.02^2) / 8 + 10 \times 0.02^2 / 4\pi^2$$

$$= 1.73 \times 10^{-4} \text{ [kg}\cdot\text{m}^2\text{]}$$

5. Provisional motor selection

In case of 200 W motor : JM = 0.17 × 10⁻⁴ [kg·m²]

6. Calculation of inertia ratio

$$JL / JM = 1.73 \times 10^{-4} / 0.17 \times 10^{-4} \text{ Therefore, the inertia ratio is "10.2" (less than "20")}$$

(In case of 100 W motor: JM = 0.064 × 10⁻⁴ Therefore, the inertia ratio is "27.0".)

7. Calculation of maximum velocity (Vmax)

$$\frac{1}{2} \times \text{Acceleration time} \times V_{\max} + \text{Constant-velocity time} \times V_{\max} + \frac{1}{2} \times \text{Deceleration time} \times V_{\max} = \text{Travel distance}$$

$$\frac{1}{2} \times 0.1 \times V_{\max} + 0.8 \times V_{\max} + \frac{1}{2} \times 0.1 \times V_{\max} = 0.3$$

$$0.9 \times V_{\max} = 0.3$$

$$= 0.3 / 0.9 = 0.334 \text{ [m/s]}$$

8. Calculation of motor velocity (N [r/min]) Ball screw lead per resolution: BP = 0.02 [m]

$$N = 0.334 / 0.02 = 16.7 \text{ [r/s]}$$

$$= 16.7 \times 60 = 1002 \text{ [min}^{-1}\text{]} < 3000 \text{ [min}^{-1}\text{]} \text{ (Rated velocity of 200W motor)}$$

9. Calculation of torque

Traveling torque

$$T_f = \frac{BP}{2\pi B\eta} (\mu g WA + F) = \frac{0.02}{2\pi \times 0.9} (0.1 \times 9.8 \times 10 + 0)$$

$$= 0.035 \text{ [N}\cdot\text{m]}$$

Acceleration torque

$$T_a = \frac{(JL + JM) \times 2\pi N \text{ [r/s]}}{\text{Acceleration time [s]}} + \text{Traveling torque}$$

$$= \frac{(1.73 \times 10^{-4} + 0.17 \times 10^{-4}) \times 2\pi \times 16.7}{0.1} + 0.035$$

$$= 0.199 + 0.035 = 0.234 \text{ [N}\cdot\text{m]}$$

Selecting Motor Capacity

$$\begin{aligned} \text{Deceleration torque } T_d &= \frac{(J_L + J_M) \times 2\pi N[\text{r/s}]}{\text{Deceleration time [s]}} - \text{Traveling torque} \\ &= \frac{(1.73 \times 10^{-4} + 0.17 \times 10^{-4}) \times 2\pi \times 16.7}{0.1} - 0.035 \\ &= 0.199 - 0.035 = 0.164 \text{ [N}\cdot\text{m]} \end{aligned}$$

10. Verification of maximum torque

$$\text{Acceleration torque} = T_a = 0.234 \text{ [N}\cdot\text{m]} < 1.91 \text{ [N}\cdot\text{m]} \text{ (Maximum torque of 200 W motor)}$$

11. Verification of effective torque

$$\begin{aligned} T_{\text{rms}} &= \sqrt{\frac{T_a^2 \times t_a + T_f^2 \times t_b + T_d^2 \times t_d}{t_c}} \\ &= \sqrt{\frac{0.234^2 \times 0.1 + 0.035^2 \times 0.8 + 0.164^2 \times 0.1}{2}} \\ &= 0.065 \text{ [N}\cdot\text{m]} < 0.64 \text{ [N}\cdot\text{m]} \text{ (Rated torque of 200 W motor)} \end{aligned}$$

12. Judging from the inertia ratio calculated above, selection of 200 W motor is preferable, although the torque margin is significantly large.

Example of motor selection

Example of motor selection for timing belt mechanism

1.Mechanism	Workpiece weight	$W_A = 3[\text{kg}]$ (including belt)
	Pulley diameter	$P_D = 0.05[\text{m}]$
	Pulley weight	$W_P = 0.5[\text{kg}]$ (Use manufacturer-specified catalog value, or calculation value.)
	Mechanical efficiency	$B\eta = 0.8$
	Coupling inertia	$J_c = 0$ (Direct connection to motor shaft)
	Belt mechanism inertia	J_B
	Pulley inertia	J_P

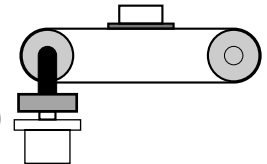

2. Running pattern

Acceleration time	$t_a = 0.1[\text{s}]$
Constant-velocity time	$t_b = 0.8[\text{s}]$
Deceleration time	$t_d = 0.1[\text{s}]$
Cycle time	$t_c = 2[\text{s}]$
Travel distance	$1[\text{m}]$

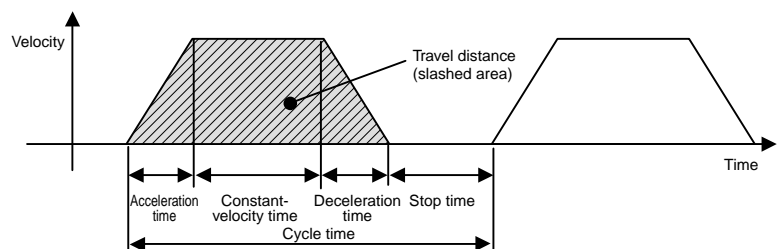

3. Load inertia $J_L = J_C + J_B + J_P$

$$\begin{aligned} &= J_C + \frac{1}{4} W_A \times P_D^2 + \frac{1}{8} W_P \times P_D^2 \times 2 \\ &= 0 + \frac{1}{4} \times 3 \times 0.05^2 + \frac{1}{8} \times 0.5 \times 0.05^2 \times 2 \\ &= 0.00219 = 21.9 \times 10^{-4} \text{ [kg}\cdot\text{m}^2] \end{aligned}$$

4. Provisional motor selection

$$\text{In case of 750 W motor : } J_M = 1.31 \times 10^{-4} \text{ [kg}\cdot\text{m}^2]$$

5. Calculation of inertia ratio

$$J_L / J_M = 21.9 \times 10^{-4} / 1.31 \times 10^{-4} \text{ Therefore, the inertia ratio is "16.7" (less than "20")}$$

6. Calculation of maximum velocity (Vmax)

$$\frac{1}{2} \times \text{Acceleration time} \times V_{\max} + \text{Constant-velocity time} \times V_{\max} + \frac{1}{2} \times \text{Deceleration time} \times V_{\max} = \text{Travel distance}$$

$$\frac{1}{2} \times 0.1 \times V_{\max} + 0.8 \times V_{\max} + \frac{1}{2} \times 0.1 \times V_{\max} = 1$$

$$0.9 \times V_{\max} = 1$$

$$V_{\max} = 1 / 0.9 = 1.111[\text{m/s}]$$

7. Calculation of motor velocity (N [r/min])

$$\text{A single rotation of pulley} : \pi \times PD = 0.157[\text{m}]$$

$$N = 1.11 / 0.157 = 7.08[\text{r/s}]$$

$$= 7.08 \times 60 = 424.8[\text{min}^{-1}] < 3000[\text{min}^{-1}] \text{ (Rated velocity of 750 W motor)}$$

8. Calculation of torque

$$\begin{aligned} \text{Traveling torque} \quad T_f &= \frac{PD}{2\eta} (\mu gWA + F) = \frac{0.05}{2 \times 0.8} (0.1 \times 9.8 \times 3 + 0) \\ &= 0.092[\text{N}\cdot\text{m}] \end{aligned}$$

$$\begin{aligned} \text{Acceleration torque} \quad T_a &= \frac{(J_L + J_M) \times 2\pi N[\text{r/s}]}{\text{Acceleration time}[\text{s}]} + \text{Traveling torque} \\ &= \frac{(21.9 \times 10^{-4} + 1.31 \times 10^{-4}) \times 2\pi \times 7.08}{0.1} + 0.092 \\ &= 1.032 + 0.092 = 1.124[\text{N}\cdot\text{m}] \end{aligned}$$

$$\begin{aligned} \text{Deceleration torque} \quad T_d &= \frac{(J_L + J_M) \times 2\pi N[\text{r/s}]}{\text{Deceleration time}[\text{s}]} - \text{Traveling torque} \\ &= \frac{(21.9 \times 10^{-4} + 1.31 \times 10^{-4}) \times 2\pi \times 7.08}{0.1} - 0.092 \\ &= 1.032 - 0.092 = 0.94[\text{N}\cdot\text{m}] \end{aligned}$$

9. Verification of maximum torque

$$\text{Acceleration torque} \quad T_a = 1.124[\text{N}\cdot\text{m}] < 7.1[\text{N}\cdot\text{m}] \text{ (Maximum torque of 750 W motor)}$$

10. Verification of effective torque

$$\begin{aligned} T_{\text{rms}} &= \sqrt{\frac{T_a^2 \times t_a + T_f^2 \times t_b + T_d^2 \times t_d}{t_c}} \\ &= \sqrt{\frac{1.124^2 \times 0.1 + 0.092^2 \times 0.8 + 0.94^2 \times 0.1}{2}} \\ &= 0.333 [\text{N}\cdot\text{m}] < 2.4 [\text{N}\cdot\text{m}] \text{ (Rated torque of 750 W motor)} \end{aligned}$$

11. Judging from the above calculation result, selection of 750W motor is acceptable.

Request for Motor Selection I : Ball screw drive

1. Driven mechanism and running data

1) Travel distance of the work load per one cycle	d ₁ :	deg
2) Cycle time	t ₀ :	s
(Fill in items 3) and 4) if required.)		
3) Acceleration time	t _a :	s
4) Deceleration time	t _d :	s
5) Stopping time	t _s :	s
6) Max. velocity	V:	mm/s
7) External force	F:	kg
8) Positioning accuracy of the work load	±	mm
9) Total weight of the work load and the table	W _A :	kg
10) Power supply voltage		V
11) Diameter of the ball screw		mm
12) Total length of the ball		mm
13) Lead of the ball screw		mm

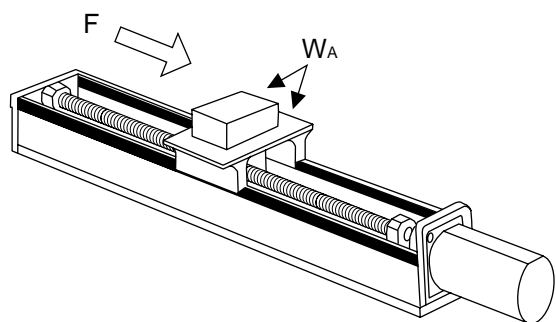
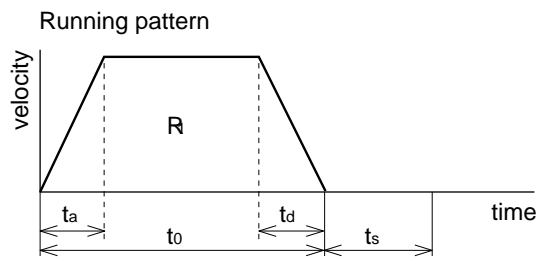

14) Traveling direction (horizontal, vertical etc.)

2. Other data

(Fill the details on specific mechanism and its configurations in the following blank.)

	Company name : _____
	Department/Section : _____
	Name : _____
	Address : _____
	Tel : _____
	Fax : _____
	E-mail address: _____

Request for Motor Selection II : Timing pulley + Ball screw drive

1. Driven mechanism and running data

1) Travel distance of the work load per one cycle	d1:	deg
2) Cycle time	to:	s
(Fill in items 3) and 4) if required.)		
3) Acceleration time	ta:	s
4) Deceleration time	td:	s
5) Stopping time	ts:	s
6) Max. velocity	V:	mm/s
7) External force	F:	kg
8) Positioning accuracy of the work load	±	mm
9) Total weight of the work load and the table	WA:	kg
10) Power supply voltage		V
11) Diameter of the ball screw		mm
12) Total length of the ball screw		mm
13) Lead of the ball screw		mm
14) Traveling		

	Motor side	Motor side
15) Diameter of the pulley	D1: mm	D2: mm
16) Weight of the pulley	W1: kg	W2: kg
(or item 17) and 18))		
17) Width of the pulley	L1: mm	
18) Material of the pulley		
19) Weight of the belt	WM: kg	

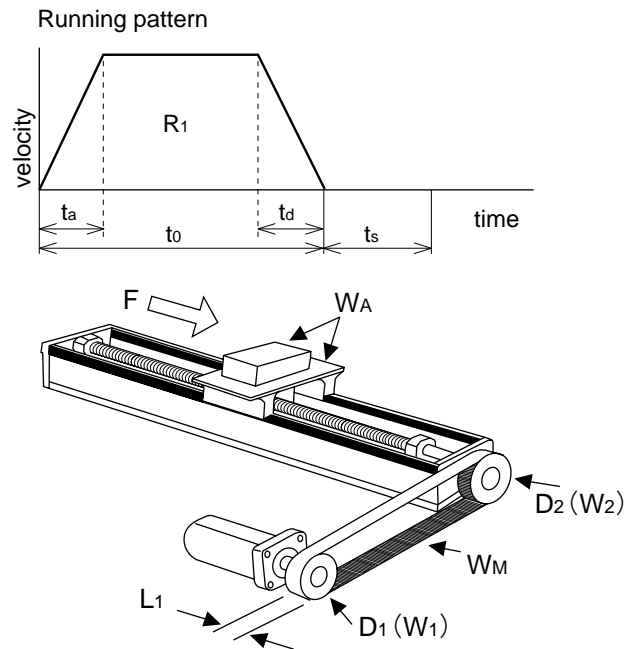

2. Other data

(Fill the details on specific mechanism and its configurations in the following blank.)

Company name :	
Department/Section :	
Name :	
Address :	
Tel :	
Fax :	
E-mail address:	

Information

Request for Motor Selection III : Belt drive

1. Driven mechanism and running data

- 1) Travel distance of the work load per one cycle d₁: deg
- 2) Cycle time t₀: s
- (Fill in items 3) and 4) if required.)
- 3) Acceleration time t_a: s
- 4) Deceleration time t_d: s
- 5) Stopping time t_s: s
- 6) Max. velocity V: mm/s
- 7) External force F: kg
- 8) Positioning accuracy of the work load ± mm
- 9) Total weight of the work load W_A: kg
- 10) Power supply voltage V
- 11) Weight of the belt W_M: kg
- 12) Diameter of the driving pulley D₁: mm
- 13) Total weight of the pulley W₁: kg

Running pattern

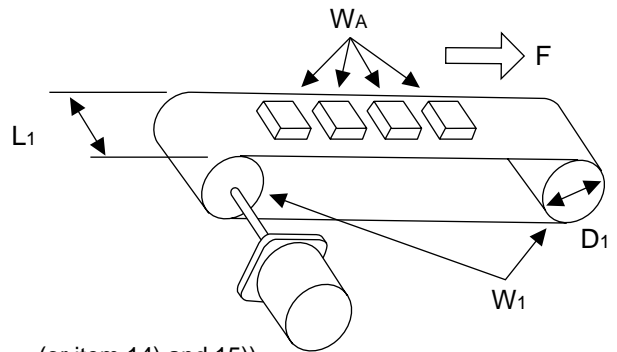
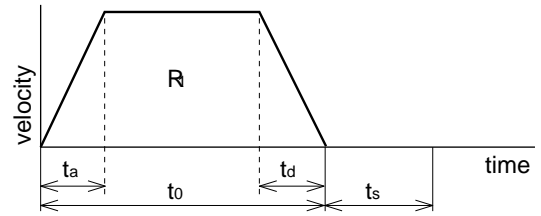

(or item 14) and 15))

- 14) Width of the pulley L₁: mm
- 15) Material of the pulley
- 16) Traveling direction (horizontal, vertical etc.)

2. Other data

(Fill the details on specific mechanism and its configurations in the following blank.)

Company name : _____

Department/Section : _____

Name : _____

Address : _____

Tel : _____

Fax : _____

E-mail address: _____

Request for Motor Selection IV : Timing pulley + Belt drive

1. Driven mechanism and running data

1) Travel distance of the work load per one cycle

d1:	deg
-----	-----

2) Cycle time

to:	s
-----	---

(Fill in items 3) and 4) if required.)

3) Acceleration time

ta:	s
-----	---

4) Deceleration time

td:	s
-----	---

5) Stopping time

ts:	s
-----	---

6) Max. velocity

V:	mm/s
----	------

7) External force

F:	kg
----	----

8) Positioning accuracy of the work load

±	mm
---	----

9) Total weight of the work load and the table

WA:	kg
-----	----

10) Power supply voltage

	V
--	---

11) Weight of motor site belt

WM:	kg
-----	----

	Motor side	Belt side
12) Diameter of the pulley	D1: mm	D2: mm
13) Weight of the pulley	W1: kg	W2: kg

(or item 14) and 15))

14) Weight of the belt

L1:	mm
-----	----

15) Material of the pulley

--

	Motor side	Belt side
16) Diameter of the pulley	D3: mm	D4: mm
17) Weight of the pulley	W3: kg	W4: kg

(or item 18) and 19))

18) Width of the pulley

L2:	mm
-----	----

19) Material of the pulley

--

20) Weight of the belt

WL:	kg
-----	----

21) Traveling direction (horizontal, vertical etc.)

--

Running pattern

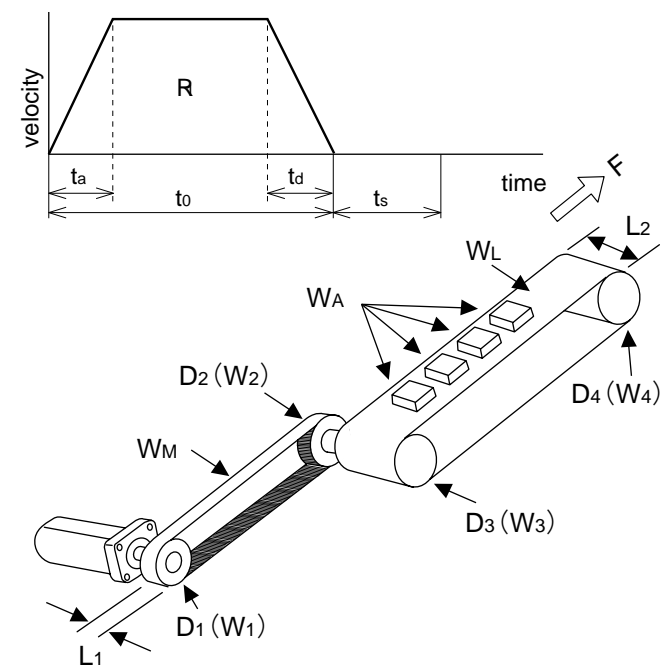

2. Other data

(Fill the details on specific mechanism and its configurations in the following blank.)

Company name : _____

Department/Section : _____

Name : _____

Address : _____

Tel : _____

Fax : _____

E-mail address: _____

Information

Request for Motor Selection V : Turntable drive

1. Driven mechanism and running data

1) Travel distance of the work load per one cycle

2) Cycle time

(Fill in items 3) and 4) if required.)

3) Acceleration time

4) Deceleration time

5) Stopping time

6) Max. rotational speed of the table

(or)

7) Positioning accuracy of the work load

8) Weight of one work load

9) Driving radius of the center of gravity of the

10) Diameter of the table

11) Mass of the table

12) Diameter of the table support

13) Power supply voltage

	Prism	Cylinder
14) Dimensions of the work load	a: <input type="text" value="mm"/>	a: <input type="text" value="mm"/>
	b: <input type="text" value="mm"/>	b: <input type="text" value="mm"/>
	c: <input type="text" value="mm"/>	c: <input type="text" value="mm"/>
15) Number of work loads	<input type="text" value="pcs"/>	

Running pattern

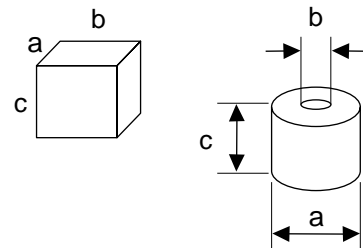
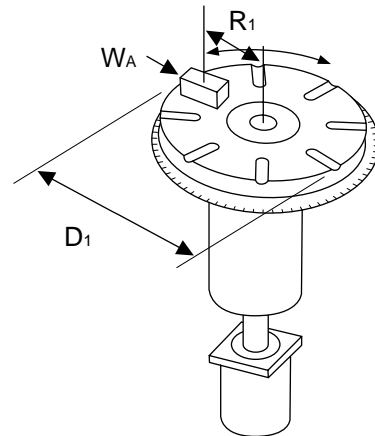
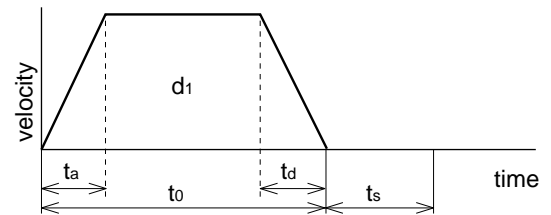

2. Other data

(Fill the details on specific mechanism and its configurations in the following blank.)

Company name :	<input style="width: 90%;" type="text"/>
Department/Section :	<input style="width: 90%;" type="text"/>
Name :	<input style="width: 90%;" type="text"/>
Address :	<input style="width: 90%;" type="text"/>
Tel :	<input style="width: 90%;" type="text"/>
Fax :	<input style="width: 90%;" type="text"/>
E-mail address:	<input style="width: 90%;" type="text"/>

Request for Motor Selection VI : Timing pulley + Turntable drive

1. Driven mechanism and running data

1) Travel distance of the work load per one cycle

2) Cycle time

(Fill in items 3) and 4) if required.)

3) Acceleration time

4) Deceleration time

5) Stopping time

6) Max. rotating speed of the table

(or)

7) Positioning accuracy of the work load

8) Weight of one work load

9) Driving radius of the center of gravity of the

10) Diameter of the table

11) Mass of the table

12) Diameter of the table support

13) Power supply voltage

14) Dimension of the work load

	(Prism)	(Cylinder)
a:	<input type="text" value="mm"/>	<input type="text" value="mm"/>
b:	<input type="text" value="mm"/>	<input type="text" value="mm"/>
c:	<input type="text" value="mm"/>	<input type="text" value="mm"/>

15) Number of work loads

	Motor side	Turntable side
16) Diameter of the pulley	<input type="text" value="D2: mm"/>	<input type="text" value="D3: mm"/>
17) Weight of the pulley	<input type="text" value="W2: kg"/>	<input type="text" value="W3: kg"/>
(or item 18) and 19))		
18) Width of the pulley	<input type="text" value="L1: mm"/>	
19) Material of the pulley	<input type="text" value=""/>	
20) Weight of the belt	<input type="text" value="WM: kg"/>	

Running pattern

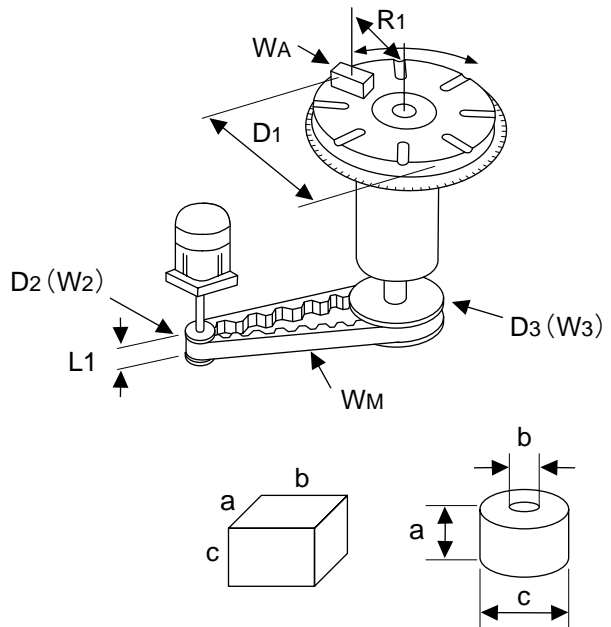
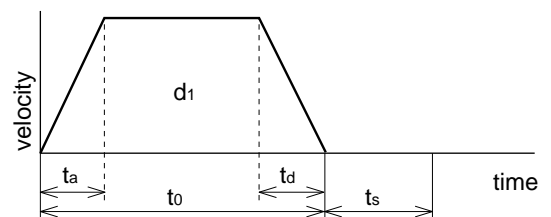

2. Other data

(Fill the details on specific mechanism and its configurations in the following blank.)

	Company name :
	Department/Section :
	Name :
	Address :
	Tel :
	Fax :
E-mail address:	

Information

Request for Motor Selection VII : Roller feed drive

1. Driven mechanism and running data

- 1) Travel distance of the work load per one cycle ℓ₁: mm
- 2) Cycle time t₀: s
- (Fill in items 3) and 4) if required.)
- 3) Acceleration time t_a: s
- 4) Deceleration time t_d: s
- 5) Stopping time t_s: s
- 6) Max. velocity v: mm/s
- 7) External pulling force F: kg
- 8) Positioning accuracy of the work load ± mm
- 9) Total weight of the work load pcs
- 10) Power supply voltage V
- 11) Diameter of the roller D₁: mm
- 12) Mass of the roller W₁: kg

Running pattern

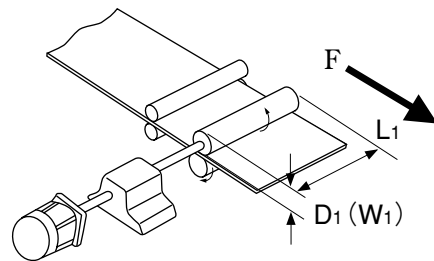
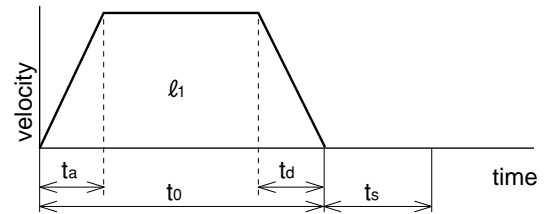

(or item 13) and 14))

- 13) Width of the roller L₁: mm
- 14) Material of the roller

2. Other data

(Fill the details on specific mechanism and its configurations in the following blank.)

Company name : _____

Department/Section : _____

Name : _____

Address : _____

Tel : _____

Fax : _____

E-mail address: _____

Request for Motor Selection VIII : Driving with Rack & Pinion

1. Driven mechanism and running data

1) Travel distance of the work load per one cycle mm

2) Cycle time s

(Fill in items 3) and 4) if required.)

3) Acceleration time s

4) Deceleration time s

5) Stopping time s

6) Max. velocity mm/s

7) External force kg

8) Positioning accuracy of the work load mm

9) Total weight of the work load kg

10) Power supply voltage V

11) Diameter of the pinion mm

12) Mass of the pinion kg

13) Traveling direction
(horizontal, vertical, etc)

Running pattern

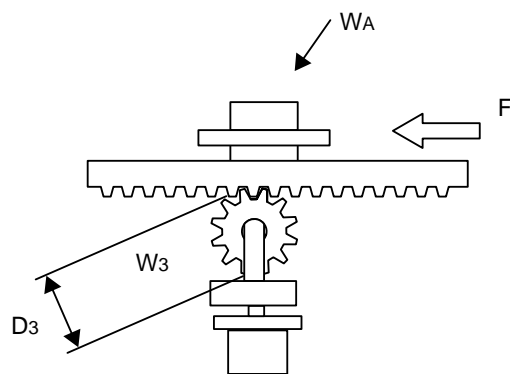
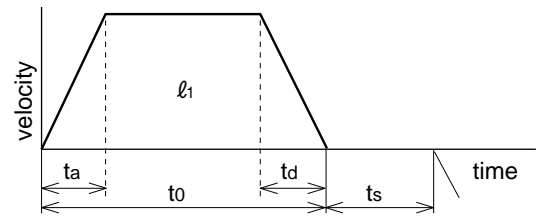

2. Other data

(Fill the details on specific mechanism and its configurations in the following blank.)

	Company name : _____
	Department/Section : _____
	Name : _____
	Address : _____
	Tel : _____
	Fax : _____
	E-mail address: _____

Information

Connection between Driver and Controller

Connection between MINAS A4 and FP2-PP22 AFP2434 (Matsushita Electric Works)

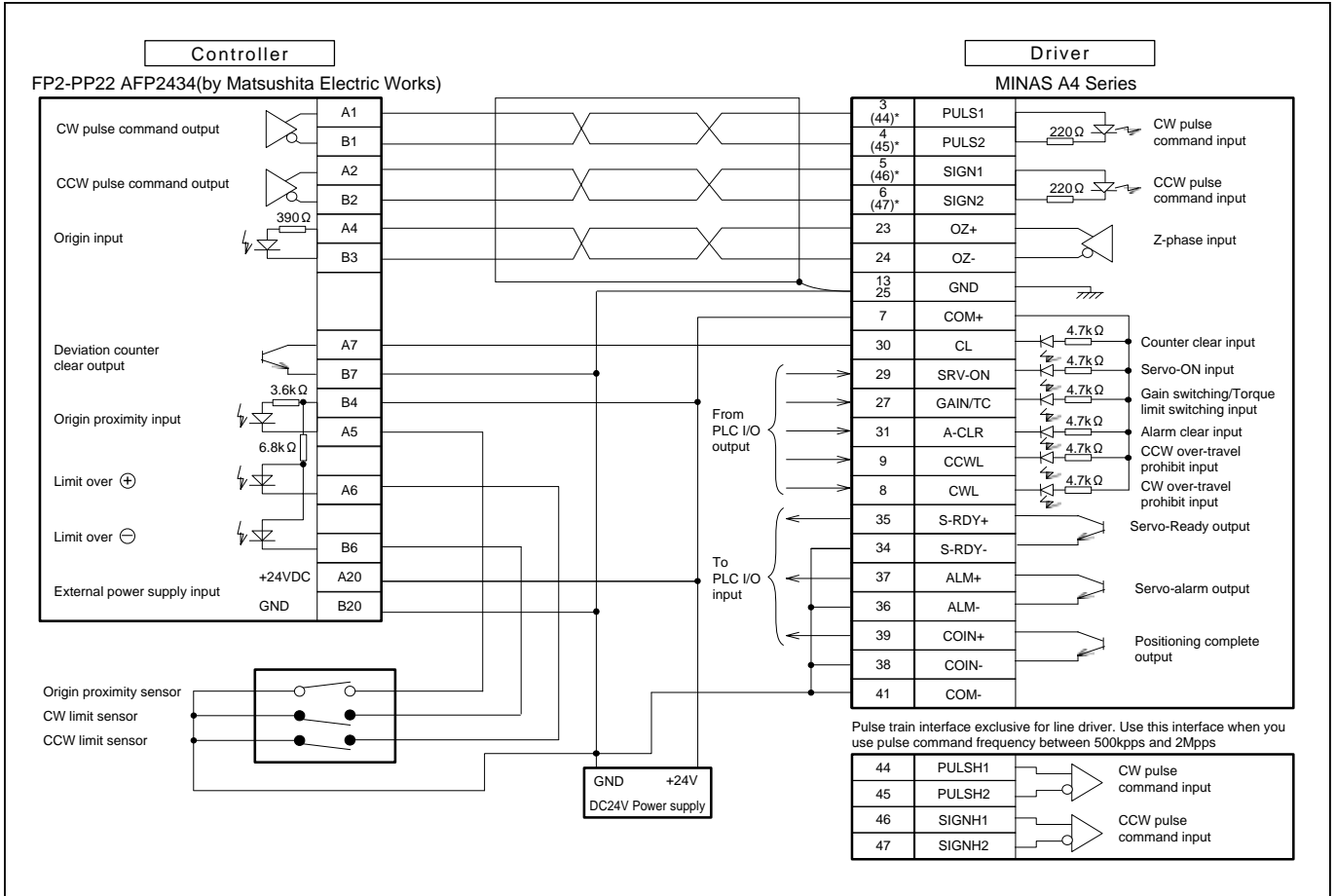

Connection between MINAS E and FP2-PP22 AFP2434 (Matsushita Electric Works)

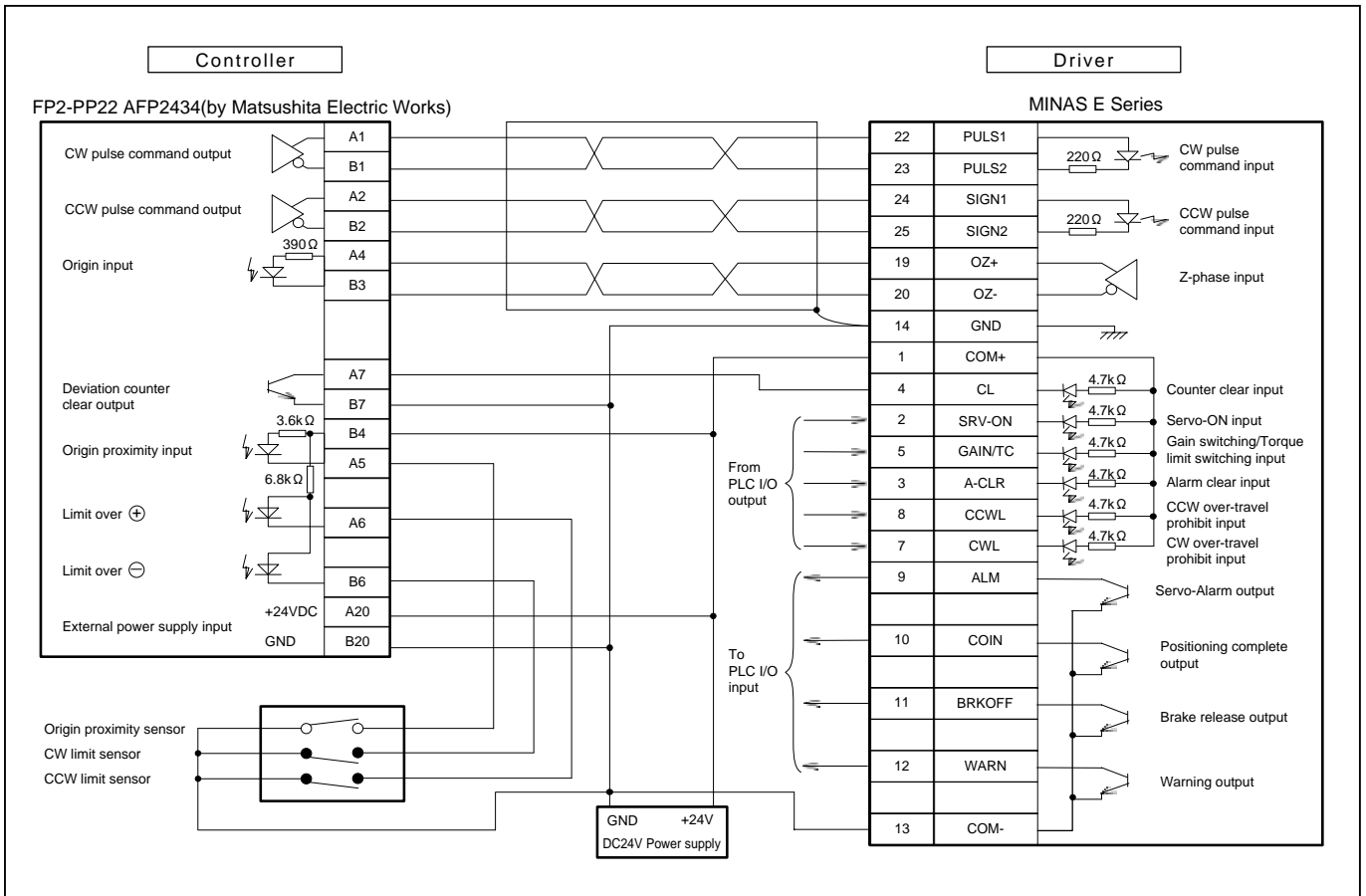

Connection between MINAS A4 and FPG-PP12 AFPG432 (Matsushita Electric Works)

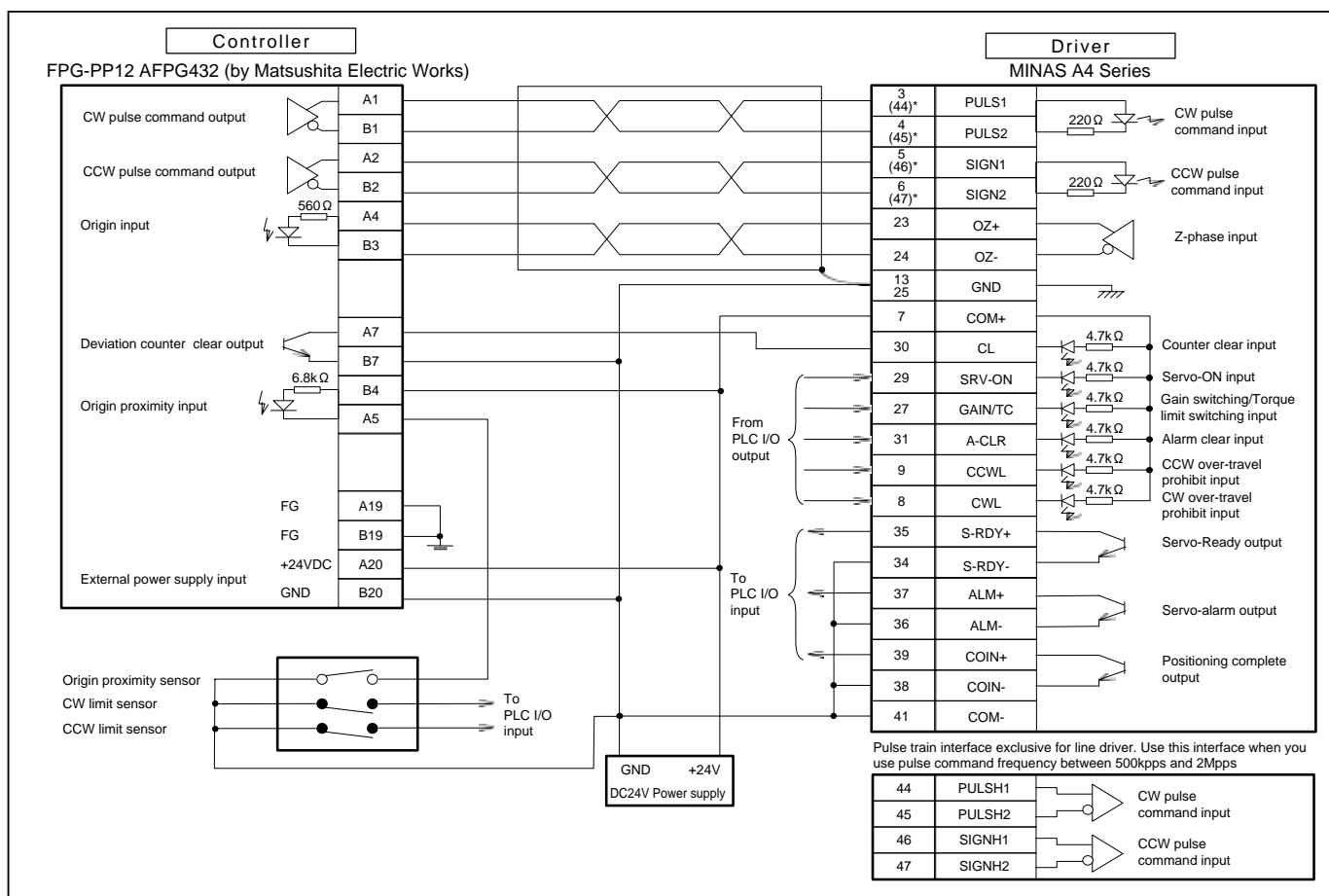

Connection between MINAS E and FPG-PP12 AFPG432 (Matsushita Electric Works)

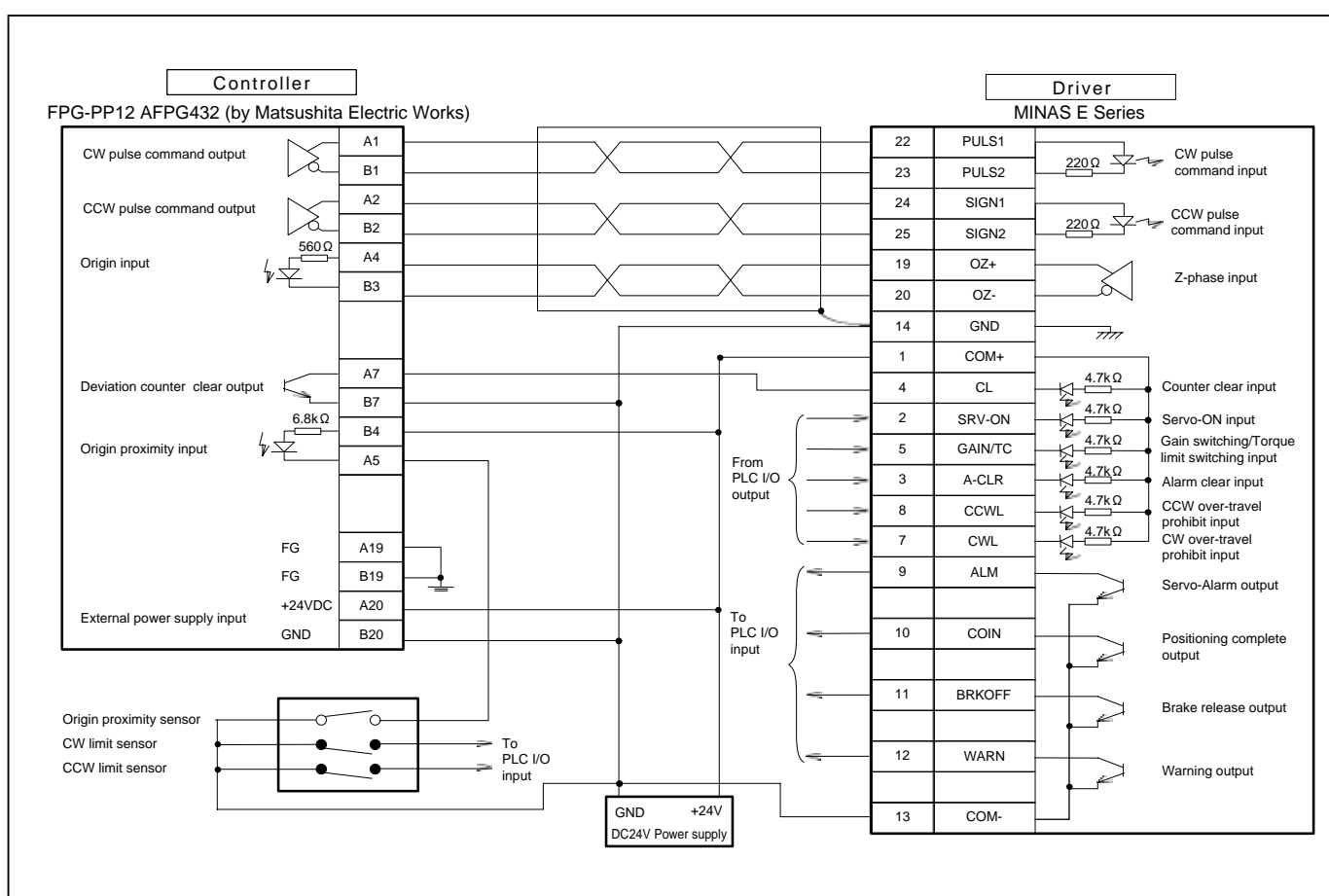

Information

Connection between Driver and Controller

Connection between MINAS A4 and FP2-PP2 AFP2430 (Matsushita Electric Works)

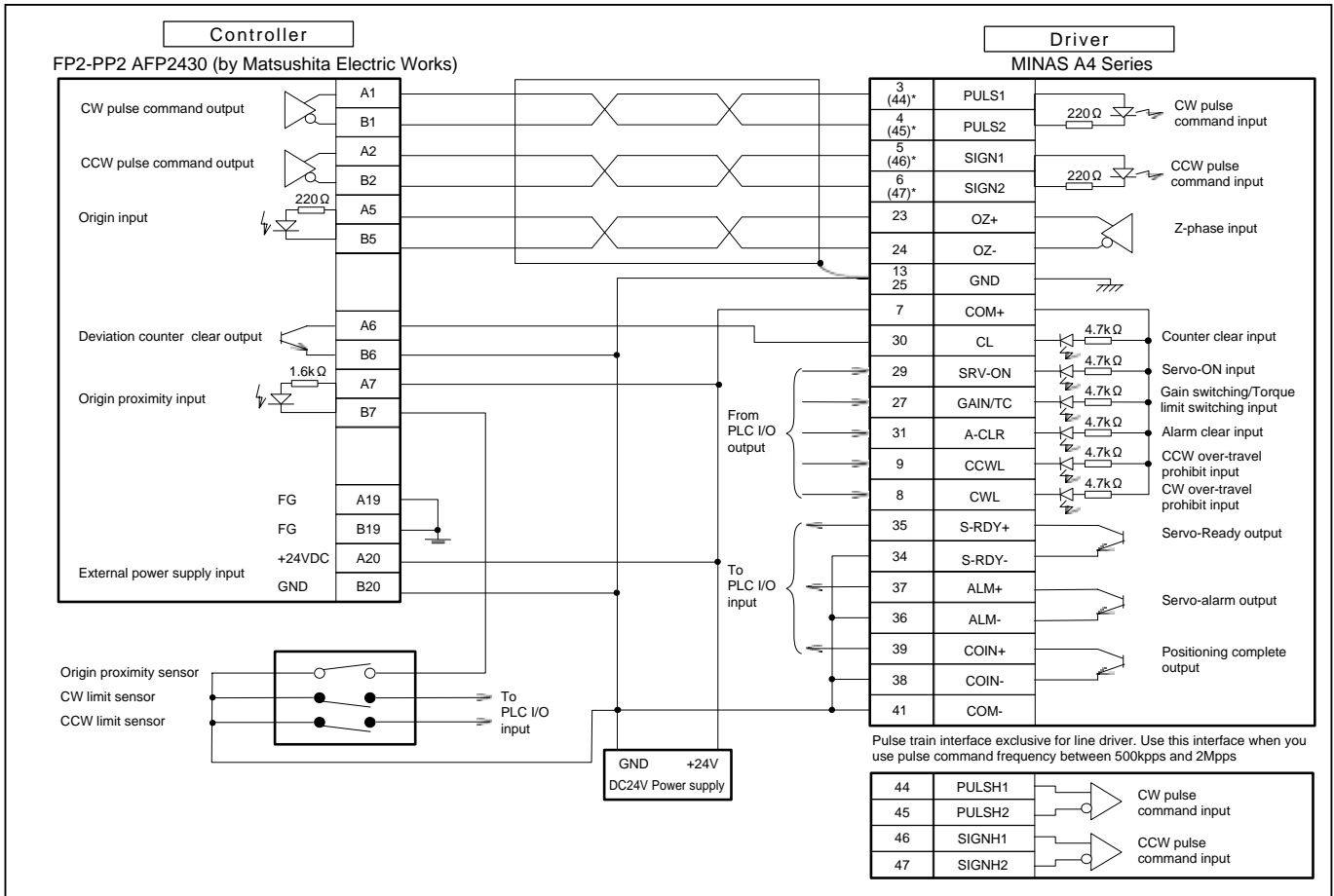

Connection between MINAS E and FP2-PP2 AFP2430 (Matsushita Electric Works)

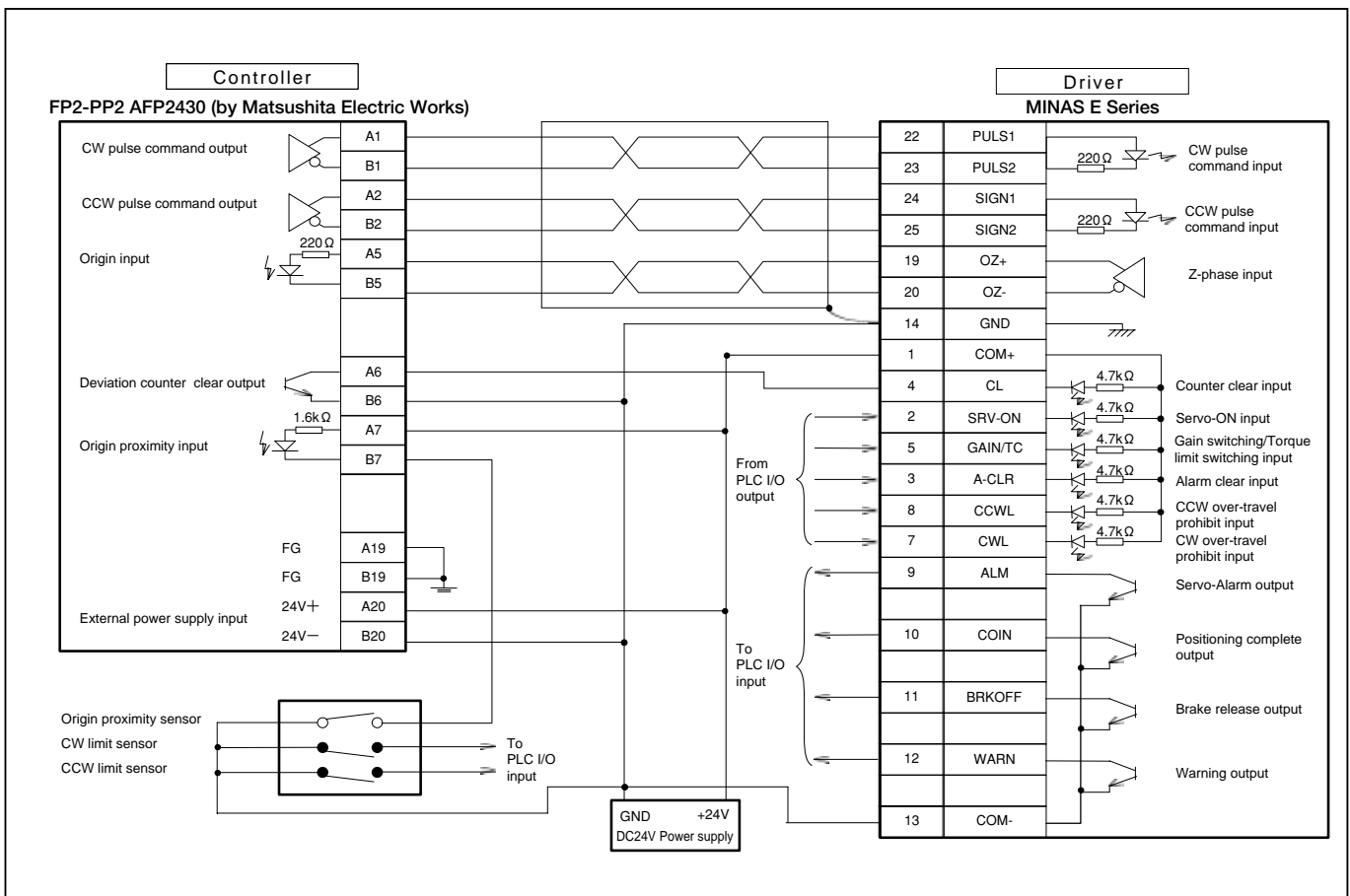

Connection between MINAS A4 and FPG-C32T (FPΣ, Matsushita Electric Works)

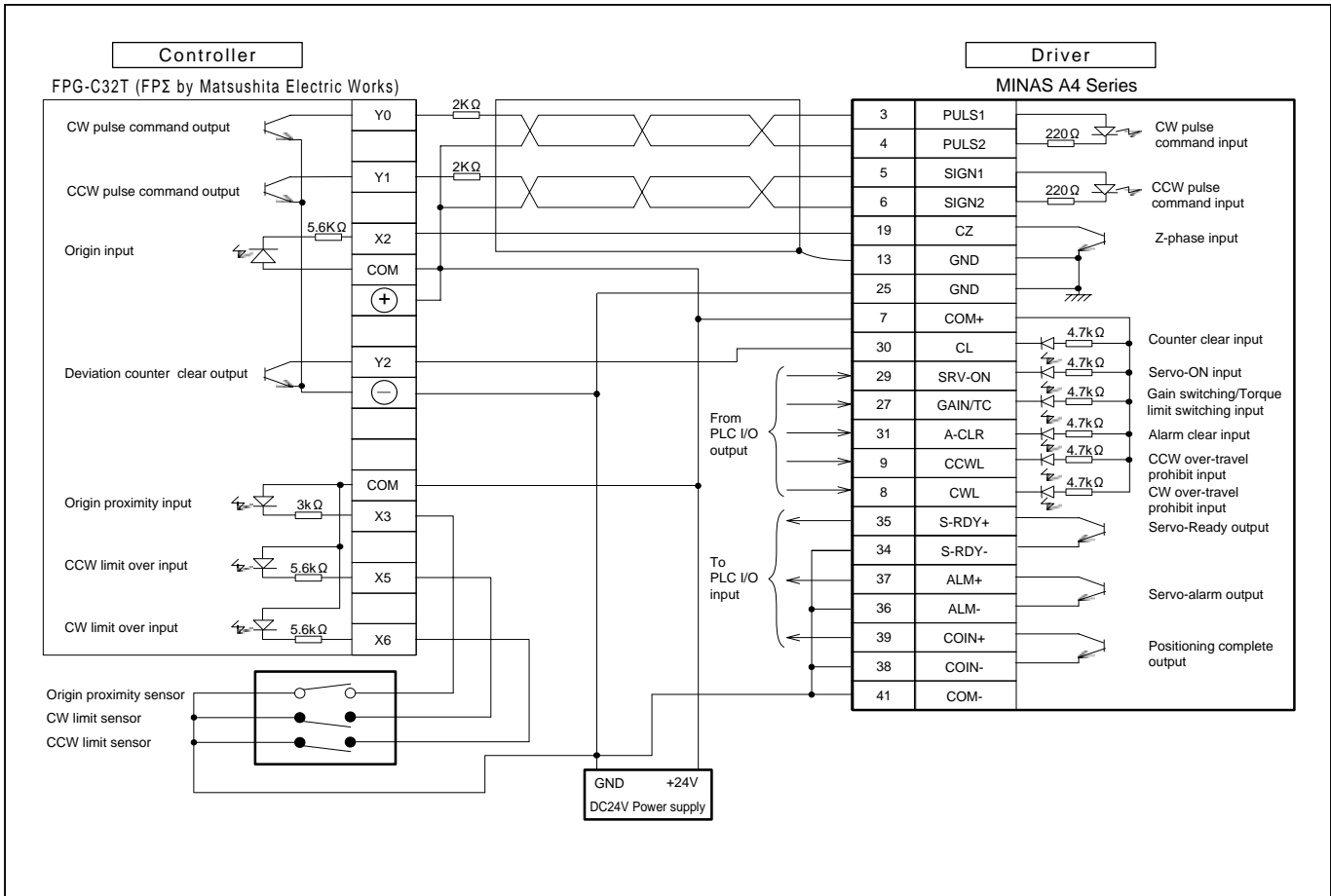

Connection between MINAS E and FPG-C32T (FPΣ, Matsushita Electric Works)

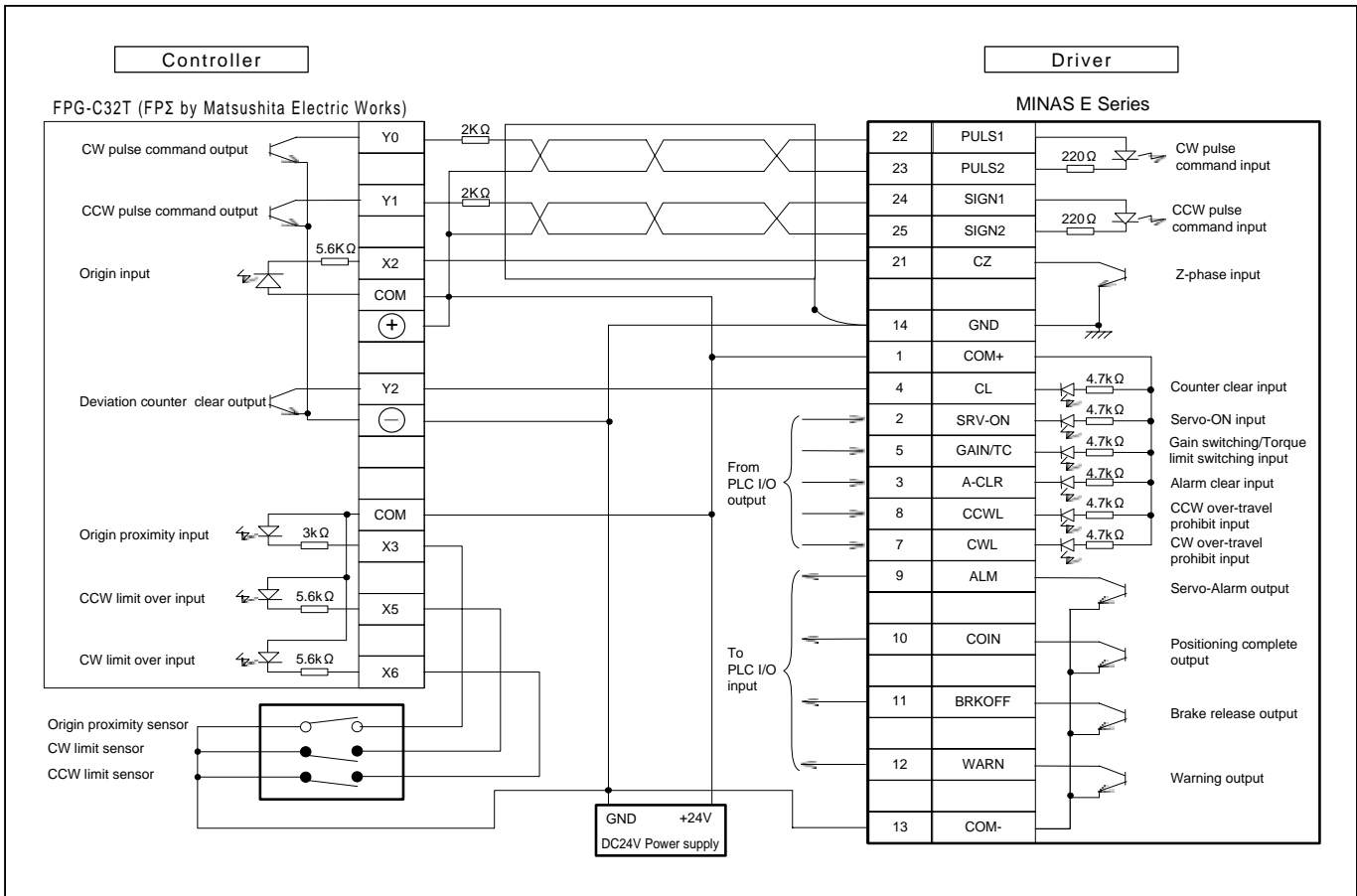

Information

Connection between Driver and Controller

Connection between MINAS A4 and F3YP14-0N/F3YP18-0N (Yokogawa Electric Corp.)

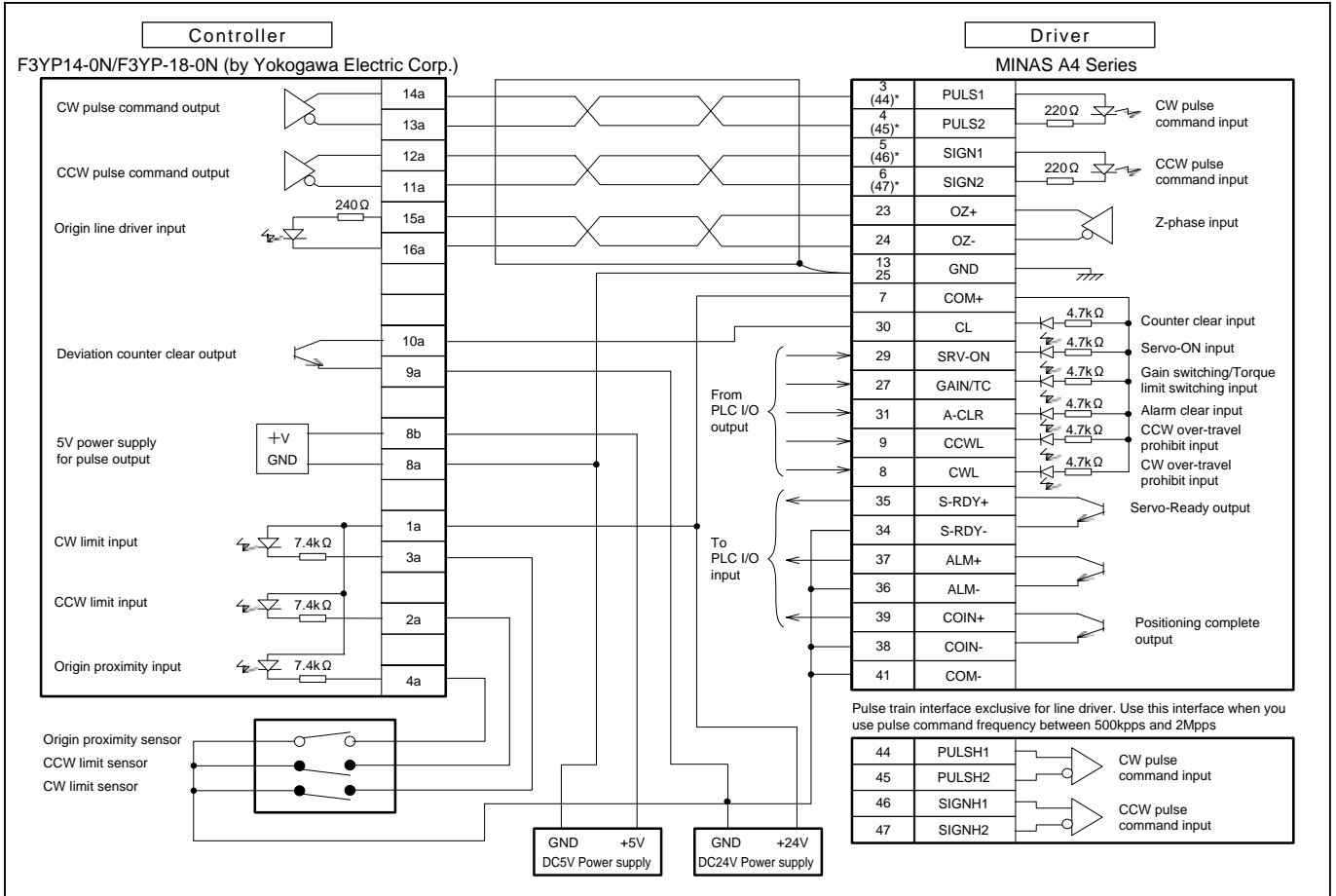

Connection between MINAS E and F3YP14-0N/F3YP18-0N (Yokogawa Electric Corp.)

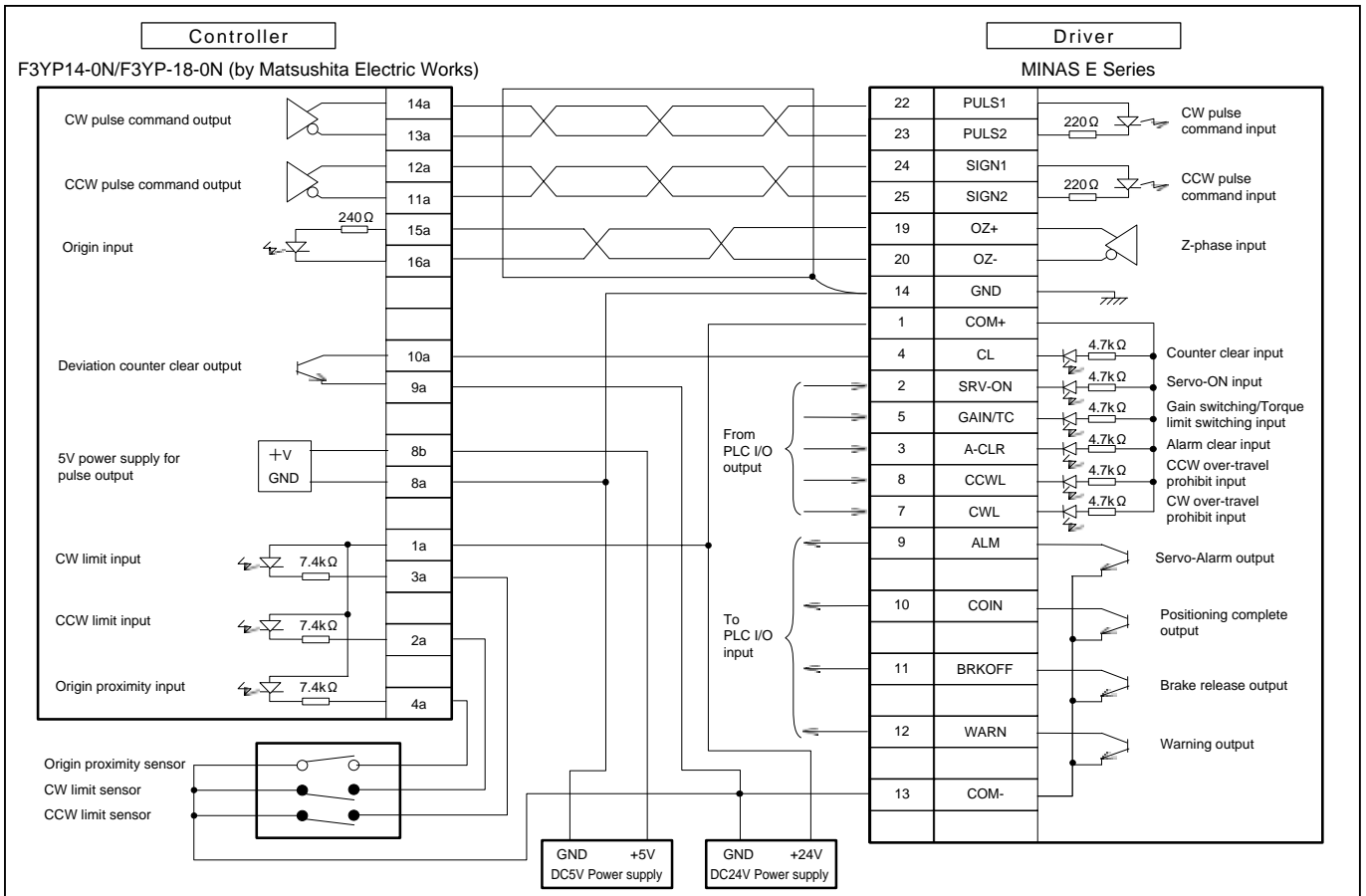

Connection between MINAS A4 and F3NC32-ON/F3NC34-ON (Yokogawa Electric Corp.)

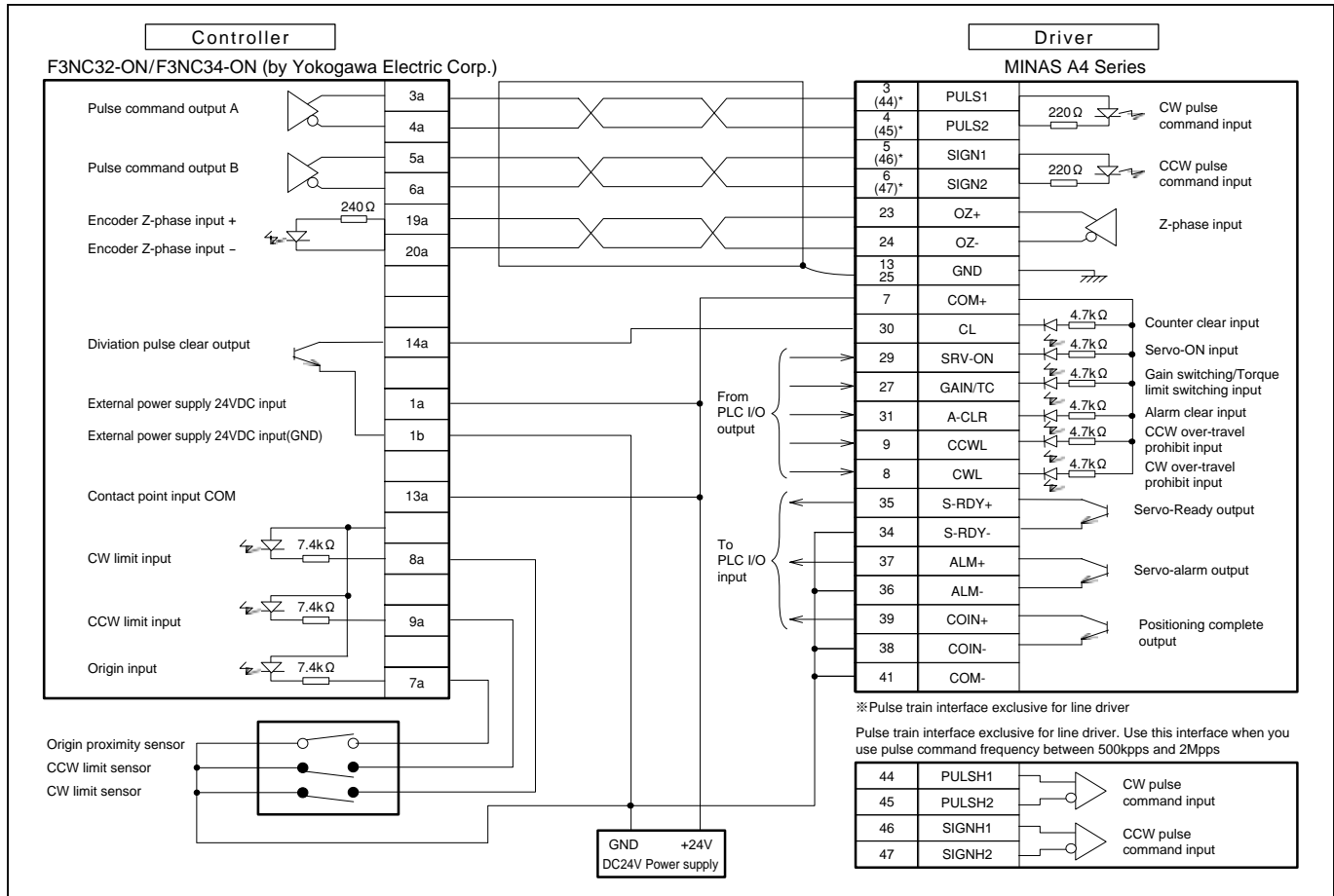

Connection between MINAS E and F3NC32-ON/F3NC34-ON (Yokogawa Electric Corp.)

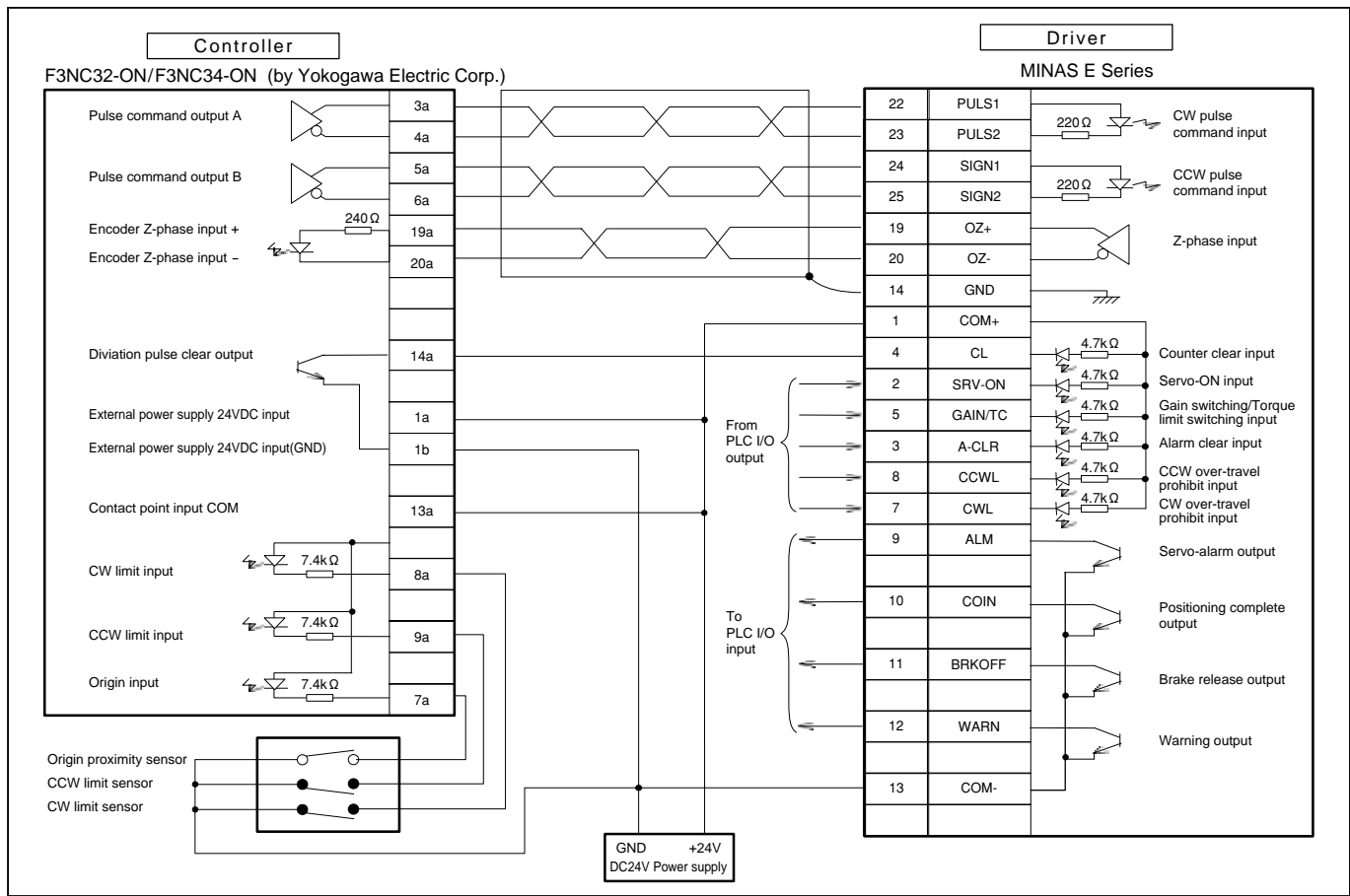

Information

Connection between Driver and Controller

Connection between MINAS A4 and CS1W-NC113(Omron Corp.)

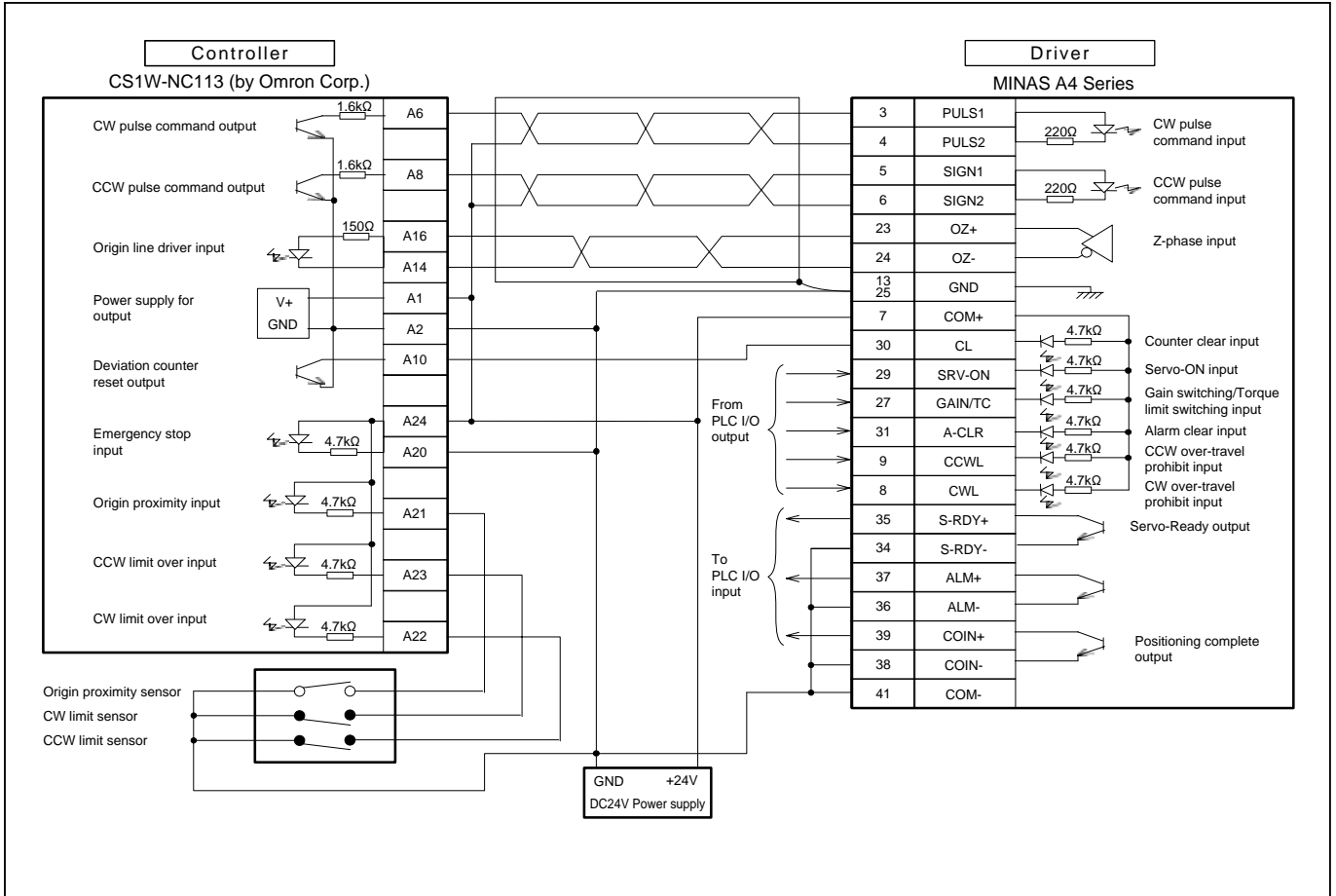

Connection between MINAS E and CS1W-NC113(Omron Corp.)

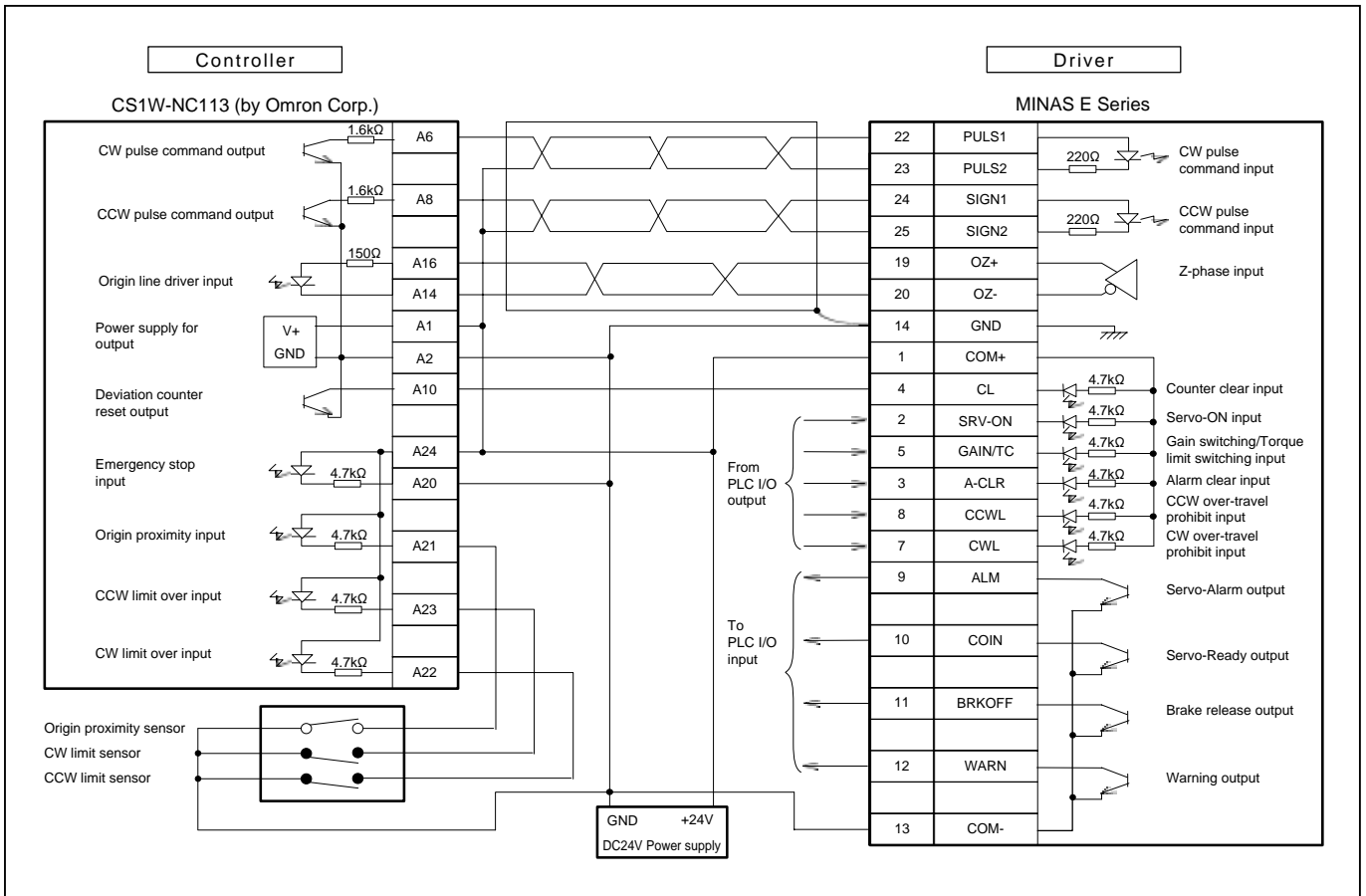

Connection between MINAS A4 and C200H-NC211 (Omron Corp.)

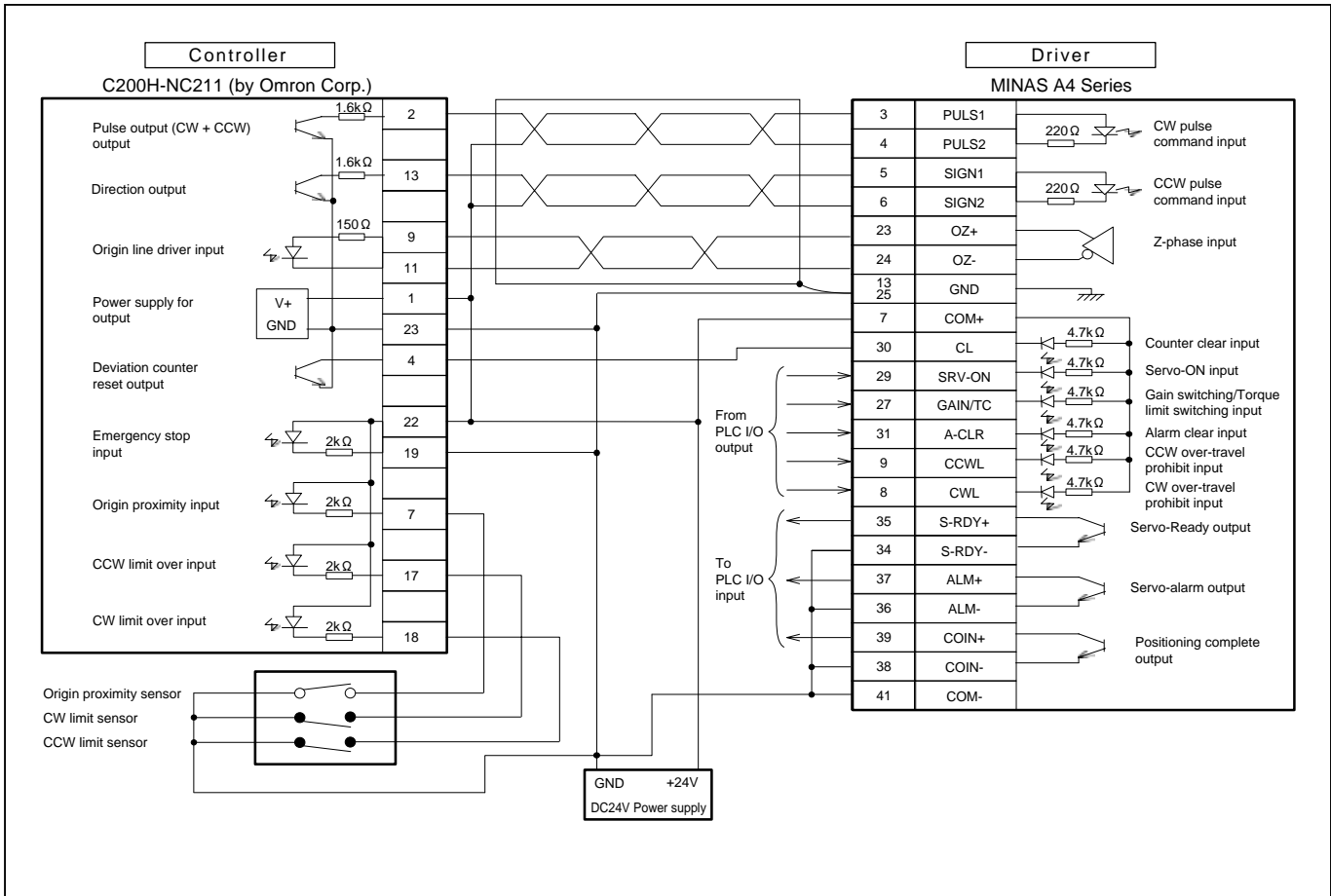

Connection between MINAS E and C200H-NC211 (Omron Corp.)

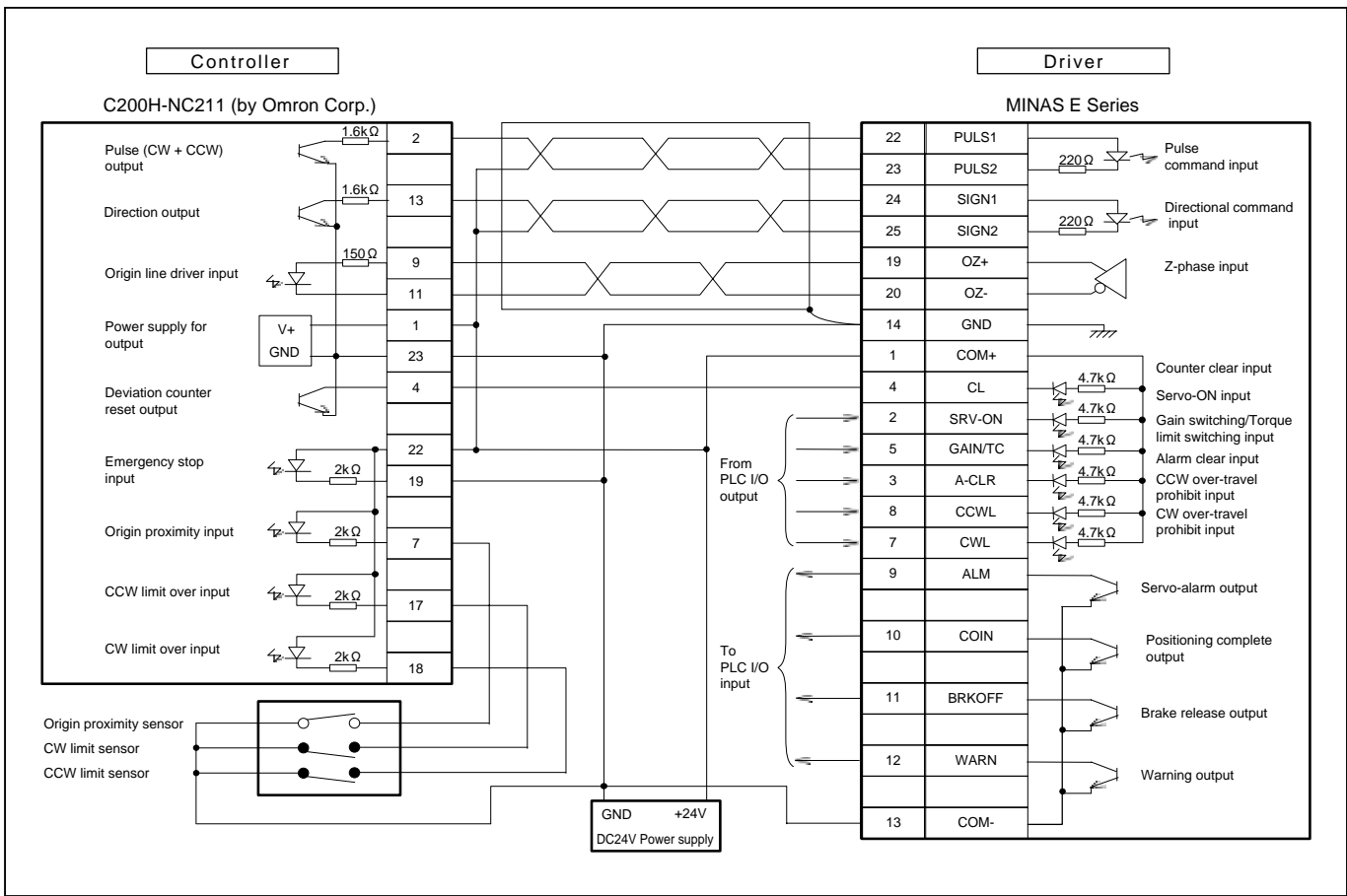

Information

Connection between Driver and Controller

Connection between MINAS A4 and CS1W-NC133(Omron Corp.)

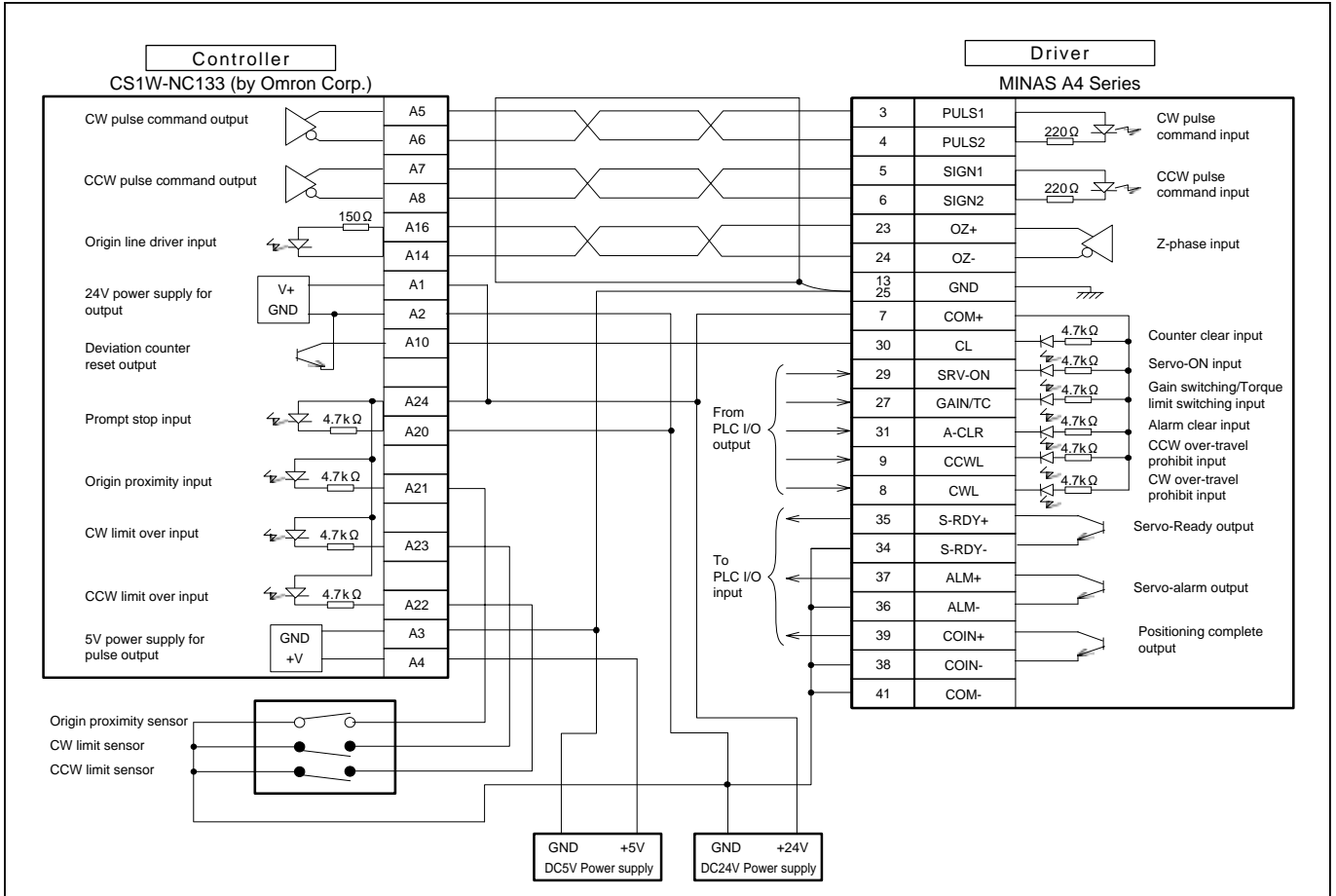

Connection between MINAS E and CS1W-NC133(Omron Corp.)

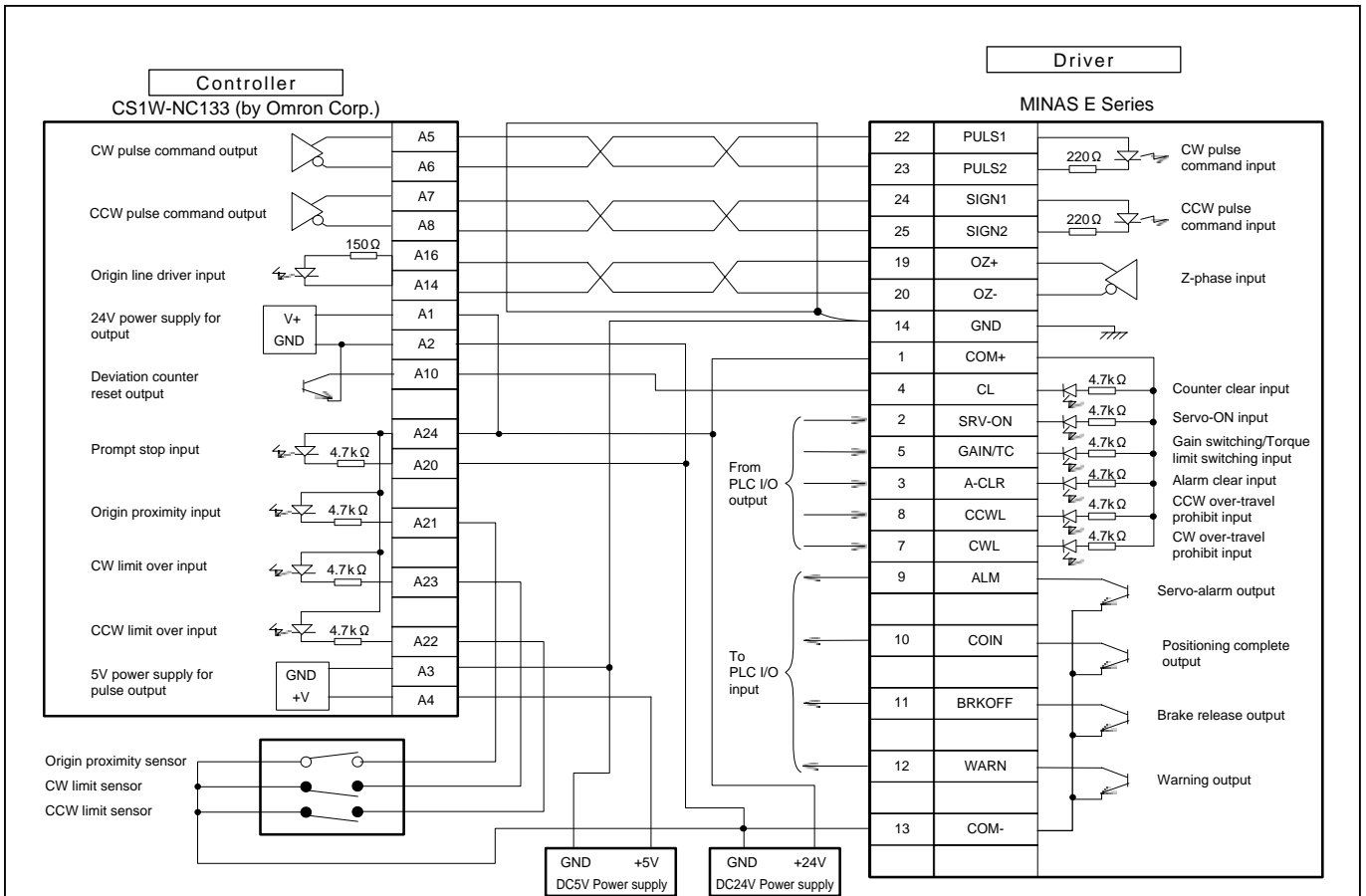

Connection between MINAS A4 and QD75D1(Mitsubishi Electric Corp.)

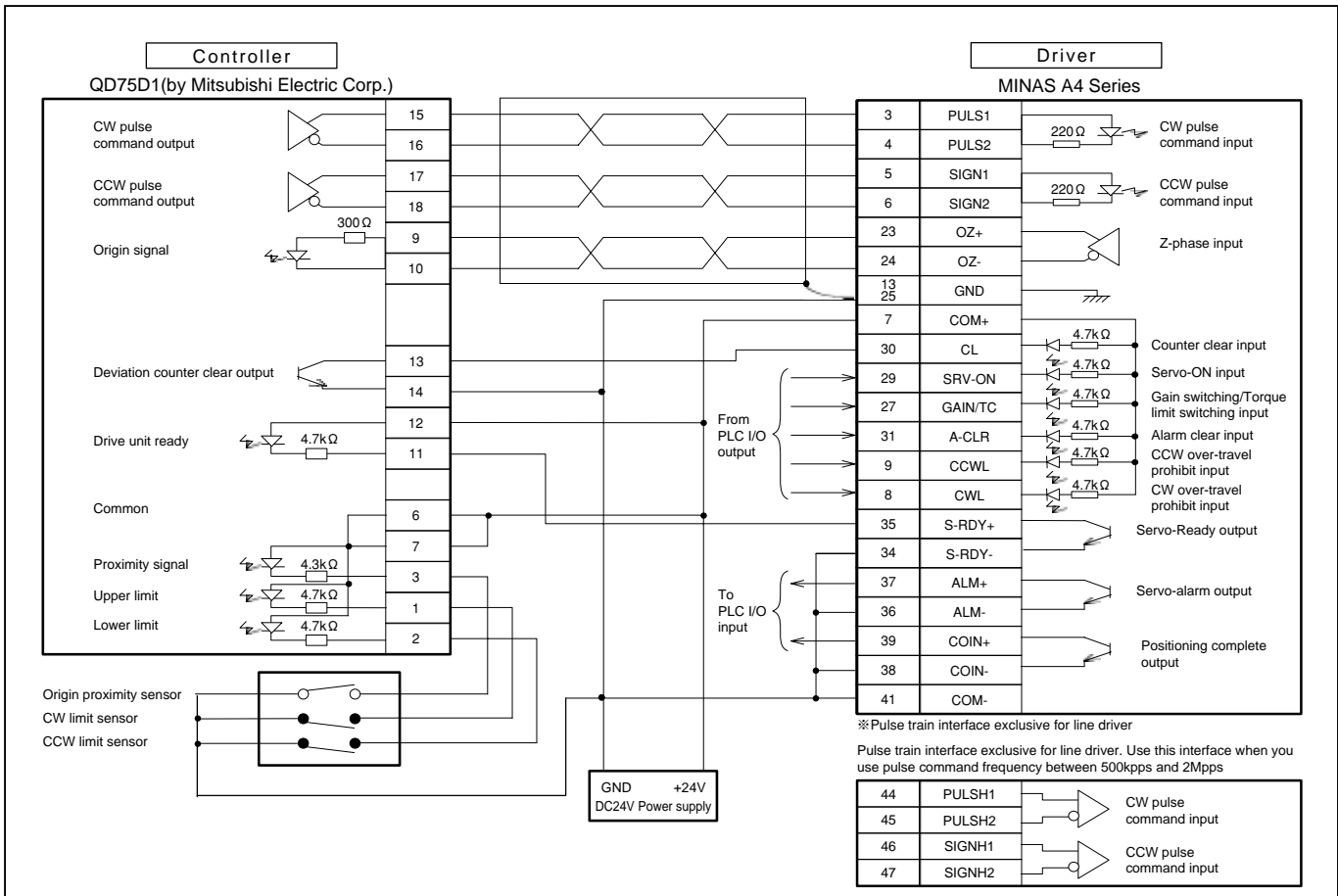

Connection between MINAS E and QD75D1(Mitsubishi Electric Corp.)

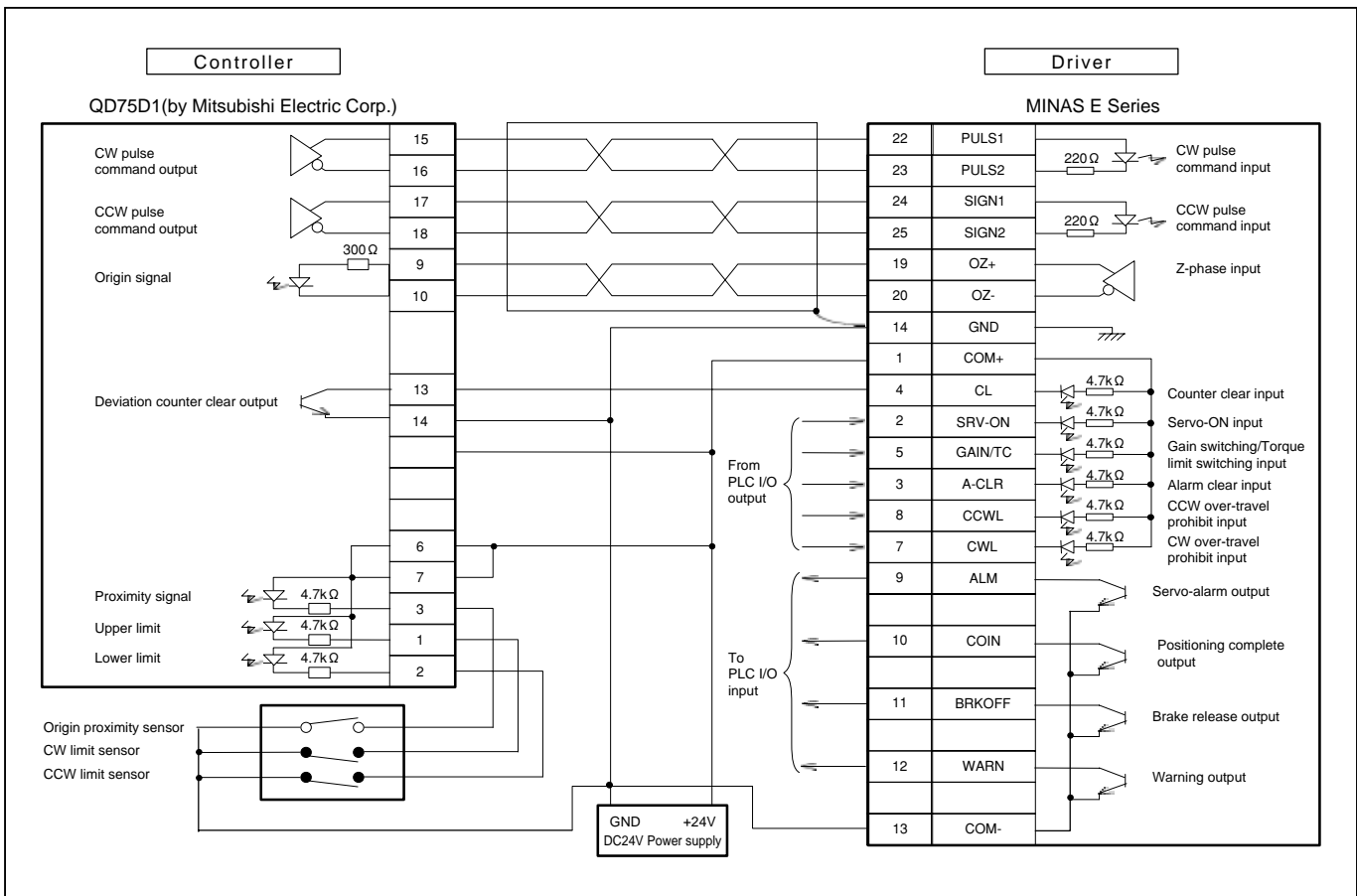

Information

Index (Alphabetical order)

● : Standard stock item

▲ : Build order item

DV0P							
Part No.	A4		Carrying page A4P		E		Delivery
	Specifications	Dimension	Specifications	Dimension	Specifications	Dimension	
DV0P0770					E27	E27	●
DV0P0800					E28	E28	●
DV0P1450	A4-110	A4-110	A4-110	A4-110	E10	E10	●
DV0P1460	A4-111	A4-111	A4-111	A4-111	E10	E10	●
DV0P1960	A4-119	A4-119	A4-119	A4-119	E28	E28	●
DV0P1970	A4-119	A4-119	A4-119	A4-119			●
DV0P1971	A4-119	A4-119	A4-119	A4-119			●
DV0P1972	A4-119	A4-119	A4-119	A4-119			●
DV0P220	A4-124	A4-124	A4-124	A4-124	E29	E29	●
DV0P221	A4-124	A4-124	A4-124	A4-124			●
DV0P222	A4-124	A4-124	A4-124	A4-124			●
DV0P223	A4-124	A4-124	A4-124	A4-124			●
DV0P224	A4-124	A4-124	A4-124	A4-124			●
DV0P225	A4-124	A4-124	A4-124	A4-124			●
DV0P227	A4-124	A4-124	A4-124	A4-124	E29	E29	●
DV0P228	A4-124	A4-124	A4-124	A4-124	E29	E29	●
DV0P2870					E26	E26	●
DV0P2890					E29	E29	●
DV0P2891					E29	E29	●
DV0P2990	A4-126	A4-126	A4-126	A4-126			●
DV0P3410	A4-110	A4-110	A4-110	A4-110			●
DV0P3470	A4-122	A4-122	A4-122	A4-122			●
DV0P3480	A4-122	A4-122	A4-122	A4-122			●
DV0P3670					E26	E26	●
DV0P3680					-	-	●
DV0P3700					-	-	●
DV0P37300					E25	E25	●
DV0P3811					E30	E30	●
DV0P39200					E25	E25	●
DV0P4160					E10	E10	●
DV0P4170	A4-110	A4-110	A4-110	A4-110			●
DV0P4180	A4-110	A4-110	A4-110	A4-110			●
DV0P4190	A4-110	A4-110	A4-110	A4-110	E10	E10	●
DV0P4200	-	-					●
DV0P4210	-	-					●
DV0P4220	A4-110	A4-110	A4-110	A4-110			●
DV0P4271	A4-123	A4-123	A4-123	A4-123			●
DV0P4272	A4-123	A4-123	A4-123	A4-123			●
DV0P4273	A4-123	A4-123	A4-123	A4-123			●
DV0P4274	A4-123	A4-123	A4-123	A4-123			●
DV0P4280	A4-125	A4-125	A4-125	A4-125			●
DV0P4281	A4-125	A4-125	A4-125	A4-125			●
DV0P4282	A4-125	A4-125	A4-125	A4-125			●
DV0P4283	A4-125	A4-125	A4-125	A4-125			●
DV0P4284	A4-125	A4-125	A4-125	A4-125			●
DV0P4285	A4-125	A4-125	A4-125	A4-125			●
DV0P4290	A4-120	A4-120	A4-120	A4-120			●
DV0P4310	A4-120	A4-120	A4-120	A4-120			●

● : Standard stock item

▲ : Build order item

DV0P							
Part No.	Carrying page				E	Dimension	Delivery
	Specifications	A4 Dimension	A4P Specifications	A4P Dimension			
DV0P4320	A4-121	A4-121	A4-121	A4-121			●
DV0P4330	A4-121	A4-121	A4-121	A4-121			●
DV0P4340	A4-121	A4-121	A4-121	A4-121			●
DV0P4350	A4-118	A4-118	A4-118	A4-118			●
DV0P4360	A4-119	A4-119	A4-119	A4-119			●
DV0P4380	A4-120	A4-120	A4-120	A4-120			●
DV0P4420	A4-124	A4-124	A4-124	A4-124	E25	E25	●
DV0P4460	A4-123	A4-123	A4-123	A4-123	E28	E28	●
DV0P4480			-	-			●
DV0P4490			-	-			●
DV0P4500	A4-118	A4-118	A4-118	A4-118			●
DV0P4510	A4-119	A4-119	A4-119	A4-119			●

● : Standard stock item

▲ : Build order item

MADDT							
Part No.	Carrying page				E	Dimension	Delivery
	Specifications	A4 Dimension	A4P Specifications	A4P Dimension			
MADDT1105	A4-15	A4-22					●
MADDT1105P			A4-39	A4-45			●
MADDT1107	A4-15	A4-22					●
MADDT1107P			A4-39	A4-45			●
MADDT1205	A4-15	A4-22					●
MADDT1205P			A4-39	A4-45			●
MADDT1207	A4-15	A4-22					●
MADDT1207P			A4-39	A4-45			●

● : Standard stock item

▲ : Build order item

MAMA							
Part No.	Carrying page				E	Dimension	Delivery
	Specifications	A4 Dimension	A4P Specifications	A4P Dimension			
MAMA012P1A	A4-49	A4-87	A4-49	A4-87			▲
MAMA012P1B	A4-49	A4-87	A4-49	A4-87			▲
MAMA012P1E	A4-49	A4-87	A4-49	A4-87			▲
MAMA012P1F	A4-49	A4-87	A4-49	A4-87			▲
MAMA012S1A	A4-49	A4-87	A4-49	A4-87			▲
MAMA012S1B	A4-49	A4-87	A4-49	A4-87			▲
MAMA012S1E	A4-49	A4-87	A4-49	A4-87			▲
MAMA012S1F	A4-49	A4-87	A4-49	A4-87			▲
MAMA022P1A	A4-49	A4-87	A4-49	A4-87			▲
MAMA022P1B	A4-49	A4-87	A4-49	A4-87			▲
MAMA022P1E	A4-49	A4-87	A4-49	A4-87			▲
MAMA022P1F	A4-49	A4-87	A4-49	A4-87			▲
MAMA022S1A	A4-49	A4-87	A4-49	A4-87			▲
MAMA022S1B	A4-49	A4-87	A4-49	A4-87			▲
MAMA022S1E	A4-49	A4-87	A4-49	A4-87			▲
MAMA022S1F	A4-49	A4-87	A4-49	A4-87			▲

Index (Alphabetical order)

● : Standard stock item

▲ : Build order item

MAMA							
Part No.	A4		Carrying page A4P		E		Delivery
	Specifications	Dimension	Specifications	Dimension	Specifications	Dimension	
MAMA042P1A	A4-49	A4-87	A4-49	A4-87			▲
MAMA042P1B	A4-49	A4-87	A4-49	A4-87			▲
MAMA042P1E	A4-49	A4-87	A4-49	A4-87			▲
MAMA042P1F	A4-49	A4-87	A4-49	A4-87			▲
MAMA042S1A	A4-49	A4-87	A4-49	A4-87			▲
MAMA042S1B	A4-49	A4-87	A4-49	A4-87			▲
MAMA042S1E	A4-49	A4-87	A4-49	A4-87			▲
MAMA042S1F	A4-49	A4-87	A4-49	A4-87			▲
MAMA082P1A	A4-49	A4-87	A4-49	A4-87			▲
MAMA082P1B	A4-49	A4-87	A4-49	A4-87			▲
MAMA082P1E	A4-49	A4-87	A4-49	A4-87			▲
MAMA082P1F	A4-49	A4-87	A4-49	A4-87			▲
MAMA082S1A	A4-49	A4-87	A4-49	A4-87			▲
MAMA082S1B	A4-49	A4-87	A4-49	A4-87			▲
MAMA082S1E	A4-49	A4-87	A4-49	A4-87			▲
MAMA082S1F	A4-49	A4-87	A4-49	A4-87			▲

● : Standard stock item

▲ : Build order item

MBDDT							
Part No.	A4		Carrying page A4P		E		Delivery
	Specifications	Dimension	Specifications	Dimension	Specifications	Dimension	
MBDDT2110	A4-15	A4-22					●
MBDDT2110P			A4-39	A4-45			●
MBDDT2210	A4-15	A4-22					●
MBDDT2210P			A4-39	A4-45			●

● : Standard stock item

▲ : Build order item

MCDDT							
Part No.	A4		Carrying page A4P		E		Delivery
	Specifications	Dimension	Specifications	Dimension	Specifications	Dimension	
MCDDT3120	A4-15	A4-23					●
MCDDT3120P			A4-39	A4-46			●
MCDDT3520	A4-15	A4-23					●
MCDDT3520P			A4-39	A4-46			●

● : Standard stock item

▲ : Build order item

MDDDT							
Part No.	A4		Carrying page A4P		E		Delivery
	Specifications	Dimension	Specifications	Dimension	Specifications	Dimension	
MDDDT3530	A4-15	A4-23					●
MDDDT3530P			A4-39	A4-46			●
MDDDT5540	A4-15	A4-23					●
MDDDT5540P			A4-39	A4-46			●

● : Standard stock item

▲ : Build order item

Part No.	Carrying page						Delivery
	A4		A4P		E		
	Specifications	Dimension	Specifications	Dimension	Specifications	Dimension	
MDMA102P1C	A4-67	A4-93	A4-67	A4-93			▲
MDMA102P1D	A4-67	A4-93	A4-67	A4-93			▲
MDMA102P1G	A4-67	A4-93	A4-67	A4-93			●
MDMA102P1H	A4-67	A4-93	A4-67	A4-93			●
MDMA102S1C	A4-67	A4-93	A4-67	A4-93			▲
MDMA102S1D	A4-67	A4-93	A4-67	A4-93			▲
MDMA102S1G	A4-67	A4-93	A4-67	A4-93			●
MDMA102S1H	A4-67	A4-93	A4-67	A4-93			●
MDMA152P1C	A4-67	A4-93	A4-67	A4-93			▲
MDMA152P1D	A4-67	A4-93	A4-67	A4-93			▲
MDMA152P1G	A4-67	A4-93	A4-67	A4-93			●
MDMA152P1H	A4-67	A4-93	A4-67	A4-93			●
MDMA152S1C	A4-67	A4-93	A4-67	A4-93			▲
MDMA152S1D	A4-67	A4-93	A4-67	A4-93			▲
MDMA152S1G	A4-67	A4-93	A4-67	A4-93			●
MDMA152S1H	A4-67	A4-93	A4-67	A4-93			●
MDMA202P1C	A4-69	A4-94	A4-69	A4-94			▲
MDMA202P1D	A4-69	A4-94	A4-69	A4-94			▲
MDMA202P1G	A4-69	A4-94	A4-69	A4-94			●
MDMA202P1H	A4-69	A4-94	A4-69	A4-94			●
MDMA202S1C	A4-69	A4-94	A4-69	A4-94			▲
MDMA202S1D	A4-69	A4-94	A4-69	A4-94			▲
MDMA202S1G	A4-69	A4-94	A4-69	A4-94			●
MDMA202S1H	A4-69	A4-94	A4-69	A4-94			●
MDMA302P1C	A4-69	A4-94	A4-69	A4-94			▲
MDMA302P1D	A4-69	A4-94	A4-69	A4-94			▲
MDMA302P1G	A4-69	A4-94	A4-69	A4-94			●
MDMA302P1H	A4-69	A4-94	A4-69	A4-94			●
MDMA302S1C	A4-69	A4-94	A4-69	A4-94			▲
MDMA302S1D	A4-69	A4-94	A4-69	A4-94			▲
MDMA302S1G	A4-69	A4-94	A4-69	A4-94			●
MDMA302S1H	A4-69	A4-94	A4-69	A4-94			●
MDMA402P1C	A4-71	A4-95	A4-71	A4-95			▲
MDMA402P1D	A4-71	A4-95	A4-71	A4-95			▲
MDMA402P1G	A4-71	A4-95	A4-71	A4-95			●
MDMA402P1H	A4-71	A4-95	A4-71	A4-95			●
MDMA402S1C	A4-71	A4-95	A4-71	A4-95			▲
MDMA402S1D	A4-71	A4-95	A4-71	A4-95			▲
MDMA402S1G	A4-71	A4-95	A4-71	A4-95			●
MDMA402S1H	A4-71	A4-95	A4-71	A4-95			●
MDMA502P1C	A4-71	A4-95	A4-71	A4-95			▲
MDMA502P1D	A4-71	A4-95	A4-71	A4-95			▲
MDMA502P1G	A4-71	A4-95	A4-71	A4-95			●
MDMA502P1H	A4-71	A4-95	A4-71	A4-95			●
MDMA502S1C	A4-71	A4-95	A4-71	A4-95			▲
MDMA502S1D	A4-71	A4-95	A4-71	A4-95			▲
MDMA502S1G	A4-71	A4-95	A4-71	A4-95			●
MDMA502S1H	A4-71	A4-95	A4-71	A4-95			●

Index (Alphabetical order)

● : Standard stock item

▲ : Build order item

MDMA							
Part No.	A4		Carrying page A4P		E		Delivery
	Specifications	Dimension	Specifications	Dimension	Specifications	Dimension	
MDMA752P1C	A4-71	A4-95					▲
MDMA752P1D	A4-71	A4-95					▲
MDMA752P1G	A4-71	A4-95					▲
MDMA752P1H	A4-71	A4-95					▲
MDMA752S1C	A4-71	A4-95					▲
MDMA752S1D	A4-71	A4-95					▲
MDMA752S1G	A4-71	A4-95					▲
MDMA752S1H	A4-71	A4-95					▲

● : Standard stock item

▲ : Build order item

MEDDT							
Part No.	A4		Carrying page A4P		E		Delivery
	Specifications	Dimension	Specifications	Dimension	Specifications	Dimension	
MEDDT7364	A4-15	A4-24					●
MEDDT7364P			A4-39	A4-47			●

● : Standard stock item

▲ : Build order item

MFDDT							
Part No.	A4		Carrying page A4P		E		Delivery
	Specifications	Dimension	Specifications	Dimension	Specifications	Dimension	
MFDDTA390	A4-15	A4-24					●
MFDDTA390P			A4-39	A4-47			●
MFDDTB3A2	A4-15	A4-24					●
MFDDTB3A2P			A4-39	A4-47			●

● : Standard stock item

▲ : Build order item

MFECA							
Part No.	A4		Carrying page A4P		E		Delivery
	Specifications	Dimension	Specifications	Dimension	Specifications	Dimension	
MFECA0030EAD	A4-115	A4-115	A4-115	A4-115			●
MFECA0030EAE	A4-115	A4-115	A4-115	A4-115			●
MFECA0030EAM	A4-115	A4-115	A4-115	A4-115	E25	E25	●
MFECA0030ESD	A4-115	A4-115	A4-115	A4-115			●
MFECA0030ESE	A4-115	A4-115	A4-115	A4-115			●
MFECA0050EAD	A4-115	A4-115	A4-115	A4-115			●
MFECA0050EAE	A4-115	A4-115	A4-115	A4-115			●
MFECA0050EAM	A4-115	A4-115	A4-115	A4-115	E25	E25	●
MFECA0050ESD	A4-115	A4-115	A4-115	A4-115			●
MFECA0050ESE	A4-115	A4-115	A4-115	A4-115			●
MFECA0100EAD	A4-115	A4-115	A4-115	A4-115			●
MFECA0100EAE	A4-115	A4-115	A4-115	A4-115			●
MFECA0100EAM	A4-115	A4-115	A4-115	A4-115	E25	E25	●
MFECA0100ESD	A4-115	A4-115	A4-115	A4-115			●
MFECA0100ESE	A4-115	A4-115	A4-115	A4-115			●
MFECA0200EAD	A4-115	A4-115	A4-115	A4-115			●

● : Standard stock item

▲ : Build order item

MFECA							
Part No.	Carrying page				E	Dimension	Delivery
	Specifications	A4 Dimension	A4P Specifications	A4P Dimension			
MFECA0200EAE	A4-115	A4-115	A4-115	A4-115			●
MFECA0200EAM	A4-115	A4-115	A4-115	A4-115	E25	E25	●
MFECA0200ESD	A4-115	A4-115	A4-115	A4-115			●
MFECA0200ESE	A4-115	A4-115	A4-115	A4-115			●

● : Standard stock item

▲ : Build order item

MFMA							
Part No.	Carrying page				E	Dimension	Delivery
	Specifications	A4 Dimension	A4P Specifications	A4P Dimension			
MFMA042P1C	A4-77	A4-99	A4-77	A4-99			▲
MFMA042P1D	A4-77	A4-99	A4-77	A4-99			▲
MFMA042P1G	A4-77	A4-99	A4-77	A4-99			▲
MFMA042P1H	A4-77	A4-99	A4-77	A4-99			▲
MFMA042S1C	A4-77	A4-99	A4-77	A4-99			▲
MFMA042S1D	A4-77	A4-99	A4-77	A4-99			▲
MFMA042S1G	A4-77	A4-99	A4-77	A4-99			▲
MFMA042S1H	A4-77	A4-99	A4-77	A4-99			▲
MFMA152P1C	A4-77	A4-99	A4-77	A4-99			▲
MFMA152P1D	A4-77	A4-99	A4-77	A4-99			▲
MFMA152P1G	A4-77	A4-99	A4-77	A4-99			▲
MFMA152P1H	A4-77	A4-99	A4-77	A4-99			▲
MFMA152S1C	A4-77	A4-99	A4-77	A4-99			▲
MFMA152S1D	A4-77	A4-99	A4-77	A4-99			▲
MFMA152S1G	A4-77	A4-99	A4-77	A4-99			▲
MFMA152S1H	A4-77	A4-99	A4-77	A4-99			▲
MFMA252P1C	A4-79	A4-100	A4-79	A4-100			▲
MFMA252P1D	A4-79	A4-100	A4-79	A4-100			▲
MFMA252P1G	A4-79	A4-100	A4-79	A4-100			▲
MFMA252P1H	A4-79	A4-100	A4-79	A4-100			▲
MFMA252S1C	A4-79	A4-100	A4-79	A4-100			▲
MFMA252S1D	A4-79	A4-100	A4-79	A4-100			▲
MFMA252S1G	A4-79	A4-100	A4-79	A4-100			▲
MFMA252S1H	A4-79	A4-100	A4-79	A4-100			▲
MFMA452P1C	A4-79	A4-100	A4-79	A4-100			▲
MFMA452P1D	A4-79	A4-100	A4-79	A4-100			▲
MFMA452P1G	A4-79	A4-100	A4-79	A4-100			▲
MFMA452P1H	A4-79	A4-100	A4-79	A4-100			▲
MFMA452S1C	A4-79	A4-100	A4-79	A4-100			▲
MFMA452S1D	A4-79	A4-100	A4-79	A4-100			▲
MFMA452S1G	A4-79	A4-100	A4-79	A4-100			▲
MFMA452S1H	A4-79	A4-100	A4-79	A4-100			▲

Index (Alphabetical order)

● : Standard stock item

▲ : Build order item

MFMCA							
Part No.	A4		Carrying page A4P		E		Delivery
	Specifications	Dimension	Specifications	Dimension	Specifications	Dimension	
MFMCA0030AEB					E25	E25	●
MFMCA0030EED	A4-116	A4-116	A4-116	A4-116			●
MFMCA0032ECD	A4-116	A4-116	A4-116	A4-116			●
MFMCA0032FCD	A4-117	A4-117	A4-117	A4-117			●
MFMCA0032FCT	A4-117	A4-117	A4-117	A4-117			●
MFMCA0033ECT	A4-116	A4-116	A4-116	A4-116			●
MFMCA0033FCT	A4-117	A4-117	A4-117	A4-117			●
MFMCA0050AEB					E25	E25	●
MFMCA0050EED	A4-116	A4-116	A4-116	A4-116			●
MFMCA0052ECD	A4-116	A4-116	A4-116	A4-116			●
MFMCA0052FCD	A4-117	A4-117	A4-117	A4-117			●
MFMCA0052FCT	A4-117	A4-117	A4-117	A4-117			●
MFMCA0053ECT	A4-116	A4-116	A4-116	A4-116			●
MFMCA0053FCT	A4-117	A4-117	A4-117	A4-117			●
MFMCA0100AEB					E25	E25	●
MFMCA0100EED	A4-116	A4-116	A4-116	A4-116			●
MFMCA0102ECD	A4-116	A4-116	A4-116	A4-116			●
MFMCA0102FCD	A4-117	A4-117	A4-117	A4-117			●
MFMCA0102FCT	A4-117	A4-117	A4-117	A4-117			●
MFMCA0103ECT	A4-116	A4-116	A4-116	A4-116			●
MFMCA0103FCT	A4-117	A4-117	A4-117	A4-117			●
MFMCA0200AEB					E25	E25	●
MFMCA0200EED	A4-116	A4-116	A4-116	A4-116			●
MFMCA0202ECD	A4-116	A4-116	A4-116	A4-116			●
MFMCA0202FCD	A4-117	A4-117	A4-117	A4-117			●
MFMCA0202FCT	A4-117	A4-117	A4-117	A4-117			●
MFMCA0203ECT	A4-116	A4-116	A4-116	A4-116			●
MFMCA0203FCT	A4-117	A4-117	A4-117	A4-117			●

● : Standard stock item

▲ : Build order item

MFMCB							
Part No.	A4		Carrying page A4P		E		Delivery
	Specifications	Dimension	Specifications	Dimension	Specifications	Dimension	
MFMCB0030GET	A4-117	A4-117	A4-117	A4-117	E25	E25	●
MFMCB0050GET	A4-117	A4-117	A4-117	A4-117	E25	E25	●
MFMCB0100GET	A4-117	A4-117	A4-117	A4-117	E25	E25	●
MFMCB0200GET	A4-117	A4-117	A4-117	A4-117	E25	E25	●

● : Standard stock item

▲ : Build order item

MFMCD							
Part No.	A4		Carrying page A4P		E		Delivery
	Specifications	Dimension	Specifications	Dimension	Specifications	Dimension	
MFMCD0032ECD	A4-116	A4-116	A4-116	A4-116			●
MFMCD0032ECT	A4-116	A4-116	A4-116	A4-116			●
MFMCD0033ECT	A4-116	A4-116	A4-116	A4-116			●
MFMCD0052ECD	A4-116	A4-116	A4-116	A4-116			●

● : Standard stock item

▲ : Build order item

MFMCD							
Part No.	Carrying page				E	Delivery	
	Specifications	A4 Dimension	A4P Specifications	A4P Dimension			Specifications
MFMCD0052ECT	A4-116	A4-116	A4-116	A4-116		●	
MFMCD0053ECT	A4-116	A4-116	A4-116	A4-116		●	
MFMCD0102ECD	A4-116	A4-116	A4-116	A4-116		●	
MFMCD0102ECT	A4-116	A4-116	A4-116	A4-116		●	
MFMCD0103ECT	A4-116	A4-116	A4-116	A4-116		●	
MFMCD0202ECD	A4-116	A4-116	A4-116	A4-116		●	
MFMCD0202ECT	A4-116	A4-116	A4-116	A4-116		●	
MFMCD0203ECT	A4-116	A4-116	A4-116	A4-116		●	

● : Standard stock item

▲ : Build order item

MGDDT							
Part No.	Carrying page				E	Delivery	
	Specifications	A4 Dimension	A4P Specifications	A4P Dimension			Specifications
MGDDTC3B4	A4-15	A4-25					

● : Standard stock item

▲ : Build order item

MGMA							
Part No.	Carrying page				E	Delivery	
	Specifications	A4 Dimension	A4P Specifications	A4P Dimension			Specifications
MGMA092P1C	A4-73	A4-96	A4-73	A4-96		▲	
MGMA092P1D	A4-73	A4-96	A4-73	A4-96		▲	
MGMA092P1G	A4-73	A4-96	A4-73	A4-96		▲	
MGMA092P1H	A4-73	A4-96	A4-73	A4-96		▲	
MGMA092S1C	A4-73	A4-96	A4-73	A4-96		▲	
MGMA092S1D	A4-73	A4-96	A4-73	A4-96		▲	
MGMA092S1G	A4-73	A4-96	A4-73	A4-96		▲	
MGMA092S1H	A4-73	A4-96	A4-73	A4-96		▲	
MGMA202P1C	A4-73	A4-96	A4-73	A4-96		▲	
MGMA202P1D	A4-73	A4-96	A4-73	A4-96		▲	
MGMA202P1G	A4-73	A4-96	A4-73	A4-96		▲	
MGMA202P1H	A4-73	A4-96	A4-73	A4-96		▲	
MGMA202S1C	A4-73	A4-96	A4-73	A4-96		▲	
MGMA202S1D	A4-73	A4-96	A4-73	A4-96		▲	
MGMA202S1G	A4-73	A4-96	A4-73	A4-96		▲	
MGMA202S1H	A4-73	A4-96	A4-73	A4-96		▲	
MGMA302P1C	A4-75	A4-97	A4-75	A4-97		▲	
MGMA302P1D	A4-75	A4-97	A4-75	A4-97		▲	
MGMA302P1G	A4-75	A4-97	A4-75	A4-97		▲	
MGMA302P1H	A4-75	A4-97	A4-75	A4-97		▲	
MGMA302S1C	A4-75	A4-97	A4-75	A4-97		▲	
MGMA302S1D	A4-75	A4-97	A4-75	A4-97		▲	
MGMA302S1G	A4-75	A4-97	A4-75	A4-97		▲	
MGMA302S1H	A4-75	A4-97	A4-75	A4-97		▲	
MGMA452P1C	A4-75	A4-97	A4-75	A4-97		▲	
MGMA452P1D	A4-75	A4-97	A4-75	A4-97		▲	
MGMA452P1G	A4-75	A4-97	A4-75	A4-97		▲	

Index (Alphabetical order)

● : Standard stock item

▲ : Build order item

MGMA							
Part No.	A4		Carrying page A4P		E		Delivery
	Specifications	Dimension	Specifications	Dimension	Specifications	Dimension	
MGMA452P1H	A4-75	A4-97	A4-75	A4-97			▲
MGMA452S1C	A4-75	A4-97	A4-75	A4-97			▲
MGMA452S1D	A4-75	A4-97	A4-75	A4-97			▲
MGMA452S1G	A4-75	A4-97	A4-75	A4-97			▲
MGMA452S1H	A4-75	A4-97	A4-75	A4-97			▲
MGMA602P1C	A4-75	A4-98					▲
MGMA602P1D	A4-75	A4-98					▲
MGMA602P1G	A4-75	A4-98					▲
MGMA602P1H	A4-75	A4-98					▲
MGMA602S1C	A4-75	A4-98					▲
MGMA602S1D	A4-75	A4-98					▲
MGMA602S1G	A4-75	A4-98					▲
MGMA602S1H	A4-75	A4-98					▲

● : Standard stock item

▲ : Build order item

MHMA							
Part No.	A4		Carrying page A4P		E		Delivery
	Specifications	Dimension	Specifications	Dimension	Specifications	Dimension	
MHMA052P1C	A4-81	A4-101	A4-81	A4-101			▲
MHMA052P1D	A4-81	A4-101	A4-81	A4-101			▲
MHMA052P1G	A4-81	A4-101	A4-81	A4-101			▲
MHMA052P1H	A4-81	A4-101	A4-81	A4-101			▲
MHMA052S1C	A4-81	A4-101	A4-81	A4-101			▲
MHMA052S1D	A4-81	A4-101	A4-81	A4-101			▲
MHMA052S1G	A4-81	A4-101	A4-81	A4-101			▲
MHMA052S1H	A4-81	A4-101	A4-81	A4-101			▲
MHMA102P1C	A4-81	A4-101	A4-81	A4-101			▲
MHMA102P1D	A4-81	A4-101	A4-81	A4-101			▲
MHMA102P1G	A4-81	A4-101	A4-81	A4-101			▲
MHMA102P1H	A4-81	A4-101	A4-81	A4-101			▲
MHMA102S1C	A4-81	A4-101	A4-81	A4-101			▲
MHMA102S1D	A4-81	A4-101	A4-81	A4-101			▲
MHMA102S1G	A4-81	A4-101	A4-81	A4-101			▲
MHMA102S1H	A4-81	A4-101	A4-81	A4-101			▲
MHMA152P1C	A4-81	A4-101	A4-81	A4-101			▲
MHMA152P1D	A4-81	A4-101	A4-81	A4-101			▲
MHMA152P1G	A4-81	A4-101	A4-81	A4-101			▲
MHMA152P1H	A4-81	A4-101	A4-81	A4-101			▲
MHMA152S1C	A4-81	A4-101	A4-81	A4-101			▲
MHMA152S1D	A4-81	A4-101	A4-81	A4-101			▲
MHMA152S1G	A4-81	A4-101	A4-81	A4-101			▲
MHMA152S1H	A4-81	A4-101	A4-81	A4-101			▲
MHMA202P1C	A4-83	A4-102	A4-83	A4-102			▲
MHMA202P1D	A4-83	A4-102	A4-83	A4-102			▲
MHMA202P1G	A4-83	A4-102	A4-83	A4-102			▲
MHMA202P1H	A4-83	A4-102	A4-83	A4-102			▲
MHMA202S1C	A4-83	A4-102	A4-83	A4-102			▲

● : Standard stock item

▲ : Build order item

MHMA								
Part No.	Carrying page				E	Delivery		
	Specifications	A4 Dimension	A4P Specifications	A4P Dimension			Dimension	
MHMA202S1D	A4-83	A4-102	A4-83	A4-102		▲		
MHMA202S1G	A4-83	A4-102	A4-83	A4-102		▲		
MHMA202S1H	A4-83	A4-102	A4-83	A4-102		▲		
MHMA302P1C	A4-83	A4-102	A4-83	A4-102		▲		
MHMA302P1D	A4-83	A4-102	A4-83	A4-102		▲		
MHMA302P1G	A4-83	A4-102	A4-83	A4-102		▲		
MHMA302P1H	A4-83	A4-102	A4-83	A4-102		▲		
MHMA302S1C	A4-83	A4-102	A4-83	A4-102		▲		
MHMA302S1D	A4-83	A4-102	A4-83	A4-102		▲		
MHMA302S1G	A4-83	A4-102	A4-83	A4-102		▲		
MHMA302S1H	A4-83	A4-102	A4-83	A4-102		▲		
MHMA402P1C	A4-83	A4-102	A4-83	A4-102		▲		
MHMA402P1D	A4-83	A4-102	A4-83	A4-102		▲		
MHMA402P1G	A4-83	A4-102	A4-83	A4-102		▲		
MHMA402P1H	A4-83	A4-102	A4-83	A4-102		▲		
MHMA402S1C	A4-83	A4-102	A4-83	A4-102		▲		
MHMA402S1D	A4-83	A4-102	A4-83	A4-102		▲		
MHMA402S1G	A4-83	A4-102	A4-83	A4-102		▲		
MHMA402S1H	A4-83	A4-102	A4-83	A4-102		▲		
MHMA502P1C	A4-83	A4-102	A4-83	A4-102		▲		
MHMA502P1D	A4-83	A4-102	A4-83	A4-102		▲		
MHMA502P1G	A4-83	A4-102	A4-83	A4-102		▲		
MHMA502P1H	A4-83	A4-102	A4-83	A4-102		▲		
MHMA502S1C	A4-83	A4-102	A4-83	A4-102		▲		
MHMA502S1D	A4-83	A4-102	A4-83	A4-102		▲		
MHMA502S1G	A4-83	A4-102	A4-83	A4-102		▲		
MHMA502S1H	A4-83	A4-102	A4-83	A4-102		▲		
MHMA752P1C	A4-85	A4-103				▲		
MHMA752P1D	A4-85	A4-103				▲		
MHMA752P1G	A4-85	A4-103				▲		
MHMA752P1H	A4-85	A4-103				▲		
MHMA752S1C	A4-85	A4-103				▲		
MHMA752S1D	A4-85	A4-103				▲		
MHMA752S1G	A4-85	A4-103				▲		
MHMA752S1H	A4-85	A4-103				▲		

● : Standard stock item
▲ : Build order item

MKDET								
Part No.	Carrying page				E	Delivery		
	Specifications	A4 Dimension	A4P Specifications	A4P Dimension			Dimension	
MKDET1105P					E20	E23	●	
MKDET1110P					E20	E23	●	
MKDET1310P					E20	E23	●	
MKDET1505P					E20	E23	●	

Index (Alphabetical order)

● : Standard stock item

▲ : Build order item

MLDET							
Part No.	A4		Carrying page A4P		E		Delivery
	Specifications	Dimension	Specifications	Dimension	Specifications	Dimension	
MLDET2110P					E20	E23	●
MLDET2210P					E20	E23	●
MLDET2310P					E20	E23	●
MLDET2510P					E20	E23	●

● : Standard stock item

▲ : Build order item

MQMA							
Part No.	A4		Carrying page A4P		E		Delivery
	Specifications	Dimension	Specifications	Dimension	Specifications	Dimension	
MQMA011P1A	A4-59	A4-90	A4-59	A4-90			▲
MQMA011P1B	A4-59	A4-90	A4-59	A4-90			▲
MQMA011P1S	A4-59	A4-90	A4-59	A4-90			▲
MQMA011P1T	A4-59	A4-90	A4-59	A4-90			▲
MQMA011S1A	A4-59	A4-90	A4-59	A4-90			▲
MQMA011S1B	A4-59	A4-90	A4-59	A4-90			▲
MQMA011S1S	A4-59	A4-90	A4-59	A4-90			▲
MQMA011S1T	A4-59	A4-90	A4-59	A4-90			▲
MQMA012P1A	A4-61	A4-90	A4-61	A4-90			▲
MQMA012P1B	A4-61	A4-90	A4-61	A4-90			▲
MQMA012P1S	A4-61	A4-90	A4-61	A4-90			▲
MQMA012P1T	A4-61	A4-90	A4-61	A4-90			▲
MQMA012S1A	A4-61	A4-90	A4-61	A4-90			▲
MQMA012S1B	A4-61	A4-90	A4-61	A4-90			▲
MQMA012S1S	A4-61	A4-90	A4-61	A4-90			▲
MQMA012S1T	A4-61	A4-90	A4-61	A4-90			▲
MQMA021P1A	A4-59	A4-90	A4-59	A4-90			▲
MQMA021P1B	A4-59	A4-90	A4-59	A4-90			▲
MQMA021P1S	A4-59	A4-90	A4-59	A4-90			▲
MQMA021P1T	A4-59	A4-90	A4-59	A4-90			▲
MQMA021S1A	A4-59	A4-90	A4-59	A4-90			▲
MQMA021S1B	A4-59	A4-90	A4-59	A4-90			▲
MQMA021S1S	A4-59	A4-90	A4-59	A4-90			▲
MQMA021S1T	A4-59	A4-90	A4-59	A4-90			▲
MQMA022P1A	A4-61	A4-90	A4-61	A4-90			▲
MQMA022P1B	A4-61	A4-90	A4-61	A4-90			▲
MQMA022P1S	A4-61	A4-90	A4-61	A4-90			▲
MQMA022P1T	A4-61	A4-90	A4-61	A4-90			▲
MQMA022S1A	A4-61	A4-90	A4-61	A4-90			▲
MQMA022S1B	A4-61	A4-90	A4-61	A4-90			▲
MQMA022S1S	A4-61	A4-90	A4-61	A4-90			▲
MQMA022S1T	A4-61	A4-90	A4-61	A4-90			▲
MQMA041P1A	A4-59	A4-90	A4-59	A4-90			▲
MQMA041P1B	A4-59	A4-90	A4-59	A4-90			▲
MQMA041P1S	A4-59	A4-90	A4-59	A4-90			▲
MQMA041P1T	A4-59	A4-90	A4-59	A4-90			▲
MQMA041S1A	A4-59	A4-90	A4-59	A4-90			▲
MQMA041S1B	A4-59	A4-90	A4-59	A4-90			▲

● : Standard stock item

▲ : Build order item

MQMA							
Part No.	Carrying page				Delivery		
	A4		A4P			E	
	Specifications	Dimension	Specifications	Dimension	Specifications	Dimension	
MQMA041S1S	A4-59	A4-90	A4-59	A4-90			▲
MQMA041S1T	A4-59	A4-90	A4-59	A4-90			▲
MQMA042P1A	A4-61	A4-90	A4-61	A4-90			▲
MQMA042P1B	A4-61	A4-90	A4-61	A4-90			▲
MQMA042P1S	A4-61	A4-90	A4-61	A4-90			▲
MQMA042P1T	A4-61	A4-90	A4-61	A4-90			▲
MQMA042S1A	A4-61	A4-90	A4-61	A4-90			▲
MQMA042S1B	A4-61	A4-90	A4-61	A4-90			▲
MQMA042S1S	A4-61	A4-90	A4-61	A4-90			▲
MQMA042S1T	A4-61	A4-90	A4-61	A4-90			▲

● : Standard stock item

▲ : Build order item

MSMA							
Part No.	Carrying page				Delivery		
	A4		A4P			E	
	Specifications	Dimension	Specifications	Dimension	Specifications	Dimension	
MSMA102P1C	A4-63	A4-91	A4-63	A4-91			▲
MSMA102P1D	A4-63	A4-91	A4-63	A4-91			▲
MSMA102P1G	A4-63	A4-91	A4-63	A4-91			●
MSMA102P1H	A4-63	A4-91	A4-63	A4-91			●
MSMA102S1C	A4-63	A4-91	A4-63	A4-91			▲
MSMA102S1D	A4-63	A4-91	A4-63	A4-91			▲
MSMA102S1G	A4-63	A4-91	A4-63	A4-91			●
MSMA102S1H	A4-63	A4-91	A4-63	A4-91			●
MSMA152P1C	A4-63	A4-91	A4-63	A4-91			▲
MSMA152P1D	A4-63	A4-91	A4-63	A4-91			▲
MSMA152P1G	A4-63	A4-91	A4-63	A4-91			●
MSMA152P1H	A4-63	A4-91	A4-63	A4-91			●
MSMA152S1C	A4-63	A4-91	A4-63	A4-91			▲
MSMA152S1D	A4-63	A4-91	A4-63	A4-91			▲
MSMA152S1G	A4-63	A4-91	A4-63	A4-91			●
MSMA152S1H	A4-63	A4-91	A4-63	A4-91			●
MSMA202P1C	A4-63	A4-91	A4-63	A4-91			▲
MSMA202P1D	A4-63	A4-91	A4-63	A4-91			▲
MSMA202P1G	A4-63	A4-91	A4-63	A4-91			●
MSMA202P1H	A4-63	A4-91	A4-63	A4-91			●
MSMA202S1C	A4-63	A4-91	A4-63	A4-91			▲
MSMA202S1D	A4-63	A4-91	A4-63	A4-91			▲
MSMA202S1G	A4-63	A4-91	A4-63	A4-91			●
MSMA202S1H	A4-63	A4-91	A4-63	A4-91			●
MSMA302P1C	A4-65	A4-92	A4-65	A4-92			▲
MSMA302P1D	A4-65	A4-92	A4-65	A4-92			▲
MSMA302P1G	A4-65	A4-92	A4-65	A4-92			●
MSMA302P1H	A4-65	A4-92	A4-65	A4-92			●
MSMA302S1C	A4-65	A4-92	A4-65	A4-92			▲
MSMA302S1D	A4-65	A4-92	A4-65	A4-92			▲
MSMA302S1G	A4-65	A4-92	A4-65	A4-92			●
MSMA302S1H	A4-65	A4-92	A4-65	A4-92			●

Index (Alphabetical order)

● : Standard stock item

▲ : Build order item

MSMA							
Part No.	A4		Carrying page A4P		E		Delivery
	Specifications	Dimension	Specifications	Dimension	Specifications	Dimension	
MSMA402P1C	A4-65	A4-92	A4-65	A4-92			▲
MSMA402PID	A4-65	A4-92	A4-65	A4-92			▲
MSMA402P1G	A4-65	A4-92	A4-65	A4-92			●
MSMA402P1H	A4-65	A4-92	A4-65	A4-92			●
MSMA402S1C	A4-65	A4-92	A4-65	A4-92			▲
MSMA402S1D	A4-65	A4-92	A4-65	A4-92			▲
MSMA402S1G	A4-65	A4-92	A4-65	A4-92			●
MSMA402S1H	A4-65	A4-92	A4-65	A4-92			●
MSMA502P1C	A4-65	A4-92	A4-65	A4-92			▲
MSMA502PID	A4-65	A4-92	A4-65	A4-92			▲
MSMA502P1G	A4-65	A4-92	A4-65	A4-92			●
MSMA502P1H	A4-65	A4-92	A4-65	A4-92			●
MSMA502S1C	A4-65	A4-92	A4-65	A4-92			▲
MSMA502S1D	A4-65	A4-92	A4-65	A4-92			▲
MSMA502S1G	A4-65	A4-92	A4-65	A4-92			●
MSMA502S1H	A4-65	A4-92	A4-65	A4-92			●

● : Standard stock item

▲ : Build order item

MSMD							
Part No.	A4		Carrying page A4P		E		Delivery
	Specifications	Dimension	Specifications	Dimension	Specifications	Dimension	
MSMD011P1A	A4-51	A4-88	A4-51	A4-88			●
MSMD011P1B	A4-51	A4-88	A4-51	A4-88			●
MSMD011P1S	A4-51	A4-88	A4-51	A4-88			●
MSMD011P1T	A4-51	A4-88	A4-51	A4-88			●
MSMD011P31N	A4-105	A4-108	A4-105	A4-108			▲
MSMD011P32N	A4-105	A4-108	A4-105	A4-108			▲
MSMD011P33N	A4-105	A4-108	A4-105	A4-108			▲
MSMD011P34N	A4-105	A4-108	A4-105	A4-108			▲
MSMD011P41N	A4-105	A4-108	A4-105	A4-108			▲
MSMD011P42N	A4-105	A4-108	A4-105	A4-108			▲
MSMD011P43N	A4-105	A4-108	A4-105	A4-108			▲
MSMD011P44N	A4-105	A4-108	A4-105	A4-108			▲
MSMD011S1A	A4-51	A4-88	A4-51	A4-88			●
MSMD011S1B	A4-51	A4-88	A4-51	A4-88			●
MSMD011S1S	A4-51	A4-88	A4-51	A4-88			●
MSMD011S1T	A4-51	A4-88	A4-51	A4-88			●
MSMD011S31N	A4-105	A4-108	A4-105	A4-108			▲
MSMD011S32N	A4-105	A4-108	A4-105	A4-108			▲
MSMD011S33N	A4-105	A4-108	A4-105	A4-108			▲
MSMD011S34N	A4-105	A4-108	A4-105	A4-108			▲
MSMD011S41N	A4-105	A4-108	A4-105	A4-108			▲
MSMD011S42N	A4-105	A4-108	A4-105	A4-108			▲
MSMD011S43N	A4-105	A4-108	A4-105	A4-108			▲
MSMD011S44N	A4-105	A4-108	A4-105	A4-108			▲
MSMD012P1A	A4-55	A4-88	A4-55	A4-88			●
MSMD012P1B	A4-55	A4-88	A4-55	A4-88			●

● : Standard stock item

▲ : Build order item

MSMD							
Part No.	Carrying page				E	Delivery	
	Specifications	A4 Dimension	A4P Specifications	A4P Dimension			Specifications
MSMD012P1S	A4-55	A4-88	A4-55	A4-88		●	
MSMD012P1T	A4-55	A4-88	A4-55	A4-88		●	
MSMD012P31N	A4-105	A4-108	A4-105	A4-108		▲	
MSMD012P32N	A4-105	A4-108	A4-105	A4-108		▲	
MSMD012P33N	A4-105	A4-108	A4-105	A4-108		▲	
MSMD012P34N	A4-105	A4-108	A4-105	A4-108		▲	
MSMD012P41N	A4-105	A4-108	A4-105	A4-108		▲	
MSMD012P42N	A4-105	A4-108	A4-105	A4-108		▲	
MSMD012P43N	A4-105	A4-108	A4-105	A4-108		▲	
MSMD012P44N	A4-105	A4-108	A4-105	A4-108		▲	
MSMD012S1A	A4-55	A4-88	A4-55	A4-88		●	
MSMD012S1B	A4-55	A4-88	A4-55	A4-88		●	
MSMD012S1S	A4-55	A4-88	A4-55	A4-88		●	
MSMD012S1T	A4-55	A4-88	A4-55	A4-88		●	
MSMD012S31N	A4-105	A4-108	A4-105	A4-108		▲	
MSMD012S32N	A4-105	A4-108	A4-105	A4-108		▲	
MSMD012S33N	A4-105	A4-108	A4-105	A4-108		▲	
MSMD012S34N	A4-105	A4-108	A4-105	A4-108		▲	
MSMD012S41N	A4-105	A4-108	A4-105	A4-108		▲	
MSMD012S42N	A4-105	A4-108	A4-105	A4-108		▲	
MSMD012S43N	A4-105	A4-108	A4-105	A4-108		▲	
MSMD012S44N	A4-105	A4-108	A4-105	A4-108		▲	
MSMD021P1A	A4-53	A4-89	A4-53	A4-89		●	
MSMD021P1B	A4-53	A4-89	A4-53	A4-89		●	
MSMD021P1S	A4-53	A4-89	A4-53	A4-89		●	
MSMD021P1T	A4-53	A4-89	A4-53	A4-89		●	
MSMD021P31N	A4-105	A4-108	A4-105	A4-108		▲	
MSMD021P32N	A4-105	A4-108	A4-105	A4-108		▲	
MSMD021P33N	A4-105	A4-108	A4-105	A4-108		▲	
MSMD021P34N	A4-105	A4-108	A4-105	A4-108		▲	
MSMD021P41N	A4-105	A4-108	A4-105	A4-108		▲	
MSMD021P42N	A4-105	A4-108	A4-105	A4-108		▲	
MSMD021P43N	A4-105	A4-108	A4-105	A4-108		▲	
MSMD021P44N	A4-105	A4-108	A4-105	A4-108		▲	
MSMD021S1A	A4-53	A4-89	A4-53	A4-89		●	
MSMD021S1B	A4-53	A4-89	A4-53	A4-89		●	
MSMD021S1S	A4-53	A4-89	A4-53	A4-89		●	
MSMD021S1T	A4-53	A4-89	A4-53	A4-89		●	
MSMD021S31N	A4-105	A4-108	A4-105	A4-108		▲	
MSMD021S32N	A4-105	A4-108	A4-105	A4-108		▲	
MSMD021S33N	A4-105	A4-108	A4-105	A4-108		▲	
MSMD021S34N	A4-105	A4-108	A4-105	A4-108		▲	
MSMD021S41N	A4-105	A4-108	A4-105	A4-108		▲	
MSMD021S42N	A4-105	A4-108	A4-105	A4-108		▲	
MSMD021S43N	A4-105	A4-108	A4-105	A4-108		▲	
MSMD021S44N	A4-105	A4-108	A4-105	A4-108		▲	
MSMD022P1A	A4-57	A4-89	A4-57	A4-89		●	
MSMD022P1B	A4-57	A4-89	A4-57	A4-89		●	

Index (Alphabetical order)

● : Standard stock item

▲ : Build order item

MSMD							
Part No.	A4		Carrying page A4P		E		Delivery
	Specifications	Dimension	Specifications	Dimension	Specifications	Dimension	
MSMD022P1S	A4-57	A4-89	A4-57	A4-89			●
MSMD022P1T	A4-57	A4-89	A4-57	A4-89			●
MSMD022P31N	A4-105	A4-108	A4-105	A4-108			▲
MSMD022P32N	A4-105	A4-108	A4-105	A4-108			▲
MSMD022P33N	A4-105	A4-108	A4-105	A4-108			▲
MSMD022P34N	A4-105	A4-108	A4-105	A4-108			▲
MSMD022P41N	A4-105	A4-108	A4-105	A4-108			▲
MSMD022P42N	A4-105	A4-108	A4-105	A4-108			▲
MSMD022P43N	A4-105	A4-108	A4-105	A4-108			▲
MSMD022P44N	A4-105	A4-108	A4-105	A4-108			▲
MSMD022S1A	A4-57	A4-89	A4-57	A4-89			●
MSMD022S1B	A4-57	A4-89	A4-57	A4-89			●
MSMD022S1S	A4-57	A4-89	A4-57	A4-89			●
MSMD022S1T	A4-57	A4-89	A4-57	A4-89			●
MSMD022S31N	A4-105	A4-108	A4-105	A4-108			▲
MSMD022S32N	A4-105	A4-108	A4-105	A4-108			▲
MSMD022S33N	A4-105	A4-108	A4-105	A4-108			▲
MSMD022S34N	A4-105	A4-108	A4-105	A4-108			▲
MSMD022S41N	A4-105	A4-108	A4-105	A4-108			▲
MSMD022S42N	A4-105	A4-108	A4-105	A4-108			▲
MSMD022S43N	A4-105	A4-108	A4-105	A4-108			▲
MSMD022S44N	A4-105	A4-108	A4-105	A4-108			▲
MSMD041P1A	A4-53	A4-89	A4-53	A4-89			●
MSMD041P1B	A4-53	A4-89	A4-53	A4-89			●
MSMD041P1S	A4-53	A4-89	A4-53	A4-89			●
MSMD041P1T	A4-53	A4-89	A4-53	A4-89			●
MSMD041P31N	A4-105	A4-108	A4-105	A4-108			▲
MSMD041P32N	A4-105	A4-108	A4-105	A4-108			▲
MSMD041P33N	A4-105	A4-108	A4-105	A4-108			▲
MSMD041P34N	A4-105	A4-108	A4-105	A4-108			▲
MSMD041P41N	A4-105	A4-108	A4-105	A4-108			▲
MSMD041P42N	A4-105	A4-108	A4-105	A4-108			▲
MSMD041P43N	A4-105	A4-108	A4-105	A4-108			▲
MSMD041P44N	A4-105	A4-108	A4-105	A4-108			▲
MSMD041S1A	A4-53	A4-89	A4-53	A4-89			●
MSMD041S1B	A4-53	A4-89	A4-53	A4-89			●
MSMD041S1S	A4-53	A4-89	A4-53	A4-89			●
MSMD041S1T	A4-53	A4-89	A4-53	A4-89			●
MSMD041S31N	A4-105	A4-108	A4-105	A4-108			▲
MSMD041S32N	A4-105	A4-108	A4-105	A4-108			▲
MSMD041S33N	A4-105	A4-108	A4-105	A4-108			▲
MSMD041S34N	A4-105	A4-108	A4-105	A4-108			▲
MSMD041S41N	A4-105	A4-108	A4-105	A4-108			▲
MSMD041S42N	A4-105	A4-108	A4-105	A4-108			▲
MSMD041S43N	A4-105	A4-108	A4-105	A4-108			▲
MSMD041S44N	A4-105	A4-108	A4-105	A4-108			▲
MSMD042P1A	A4-57	A4-89	A4-57	A4-89			●
MSMD042P1B	A4-57	A4-89	A4-57	A4-89			●

● : Standard stock item

▲ : Build order item

MSMD							
Part No.	Carrying page				E	Delivery	
	A4		A4P				Dimension
	Specifications	Dimension	Specifications	Dimension	Dimension		
MSMD042P1S	A4-57	A4-89	A4-57	A4-89		●	
MSMD042P1T	A4-57	A4-89	A4-57	A4-89		●	
MSMD042P31N	A4-105	A4-108	A4-105	A4-108		▲	
MSMD042P32N	A4-105	A4-108	A4-105	A4-108		▲	
MSMD042P33N	A4-105	A4-108	A4-105	A4-108		▲	
MSMD042P34N	A4-105	A4-108	A4-105	A4-108		▲	
MSMD042P41N	A4-105	A4-108	A4-105	A4-108		▲	
MSMD042P42N	A4-105	A4-108	A4-105	A4-108		▲	
MSMD042P43N	A4-105	A4-108	A4-105	A4-108		▲	
MSMD042P44N	A4-105	A4-108	A4-105	A4-108		▲	
MSMD042S1A	A4-57	A4-89	A4-57	A4-89		●	
MSMD042S1B	A4-57	A4-89	A4-57	A4-89		●	
MSMD042S1S	A4-57	A4-89	A4-57	A4-89		●	
MSMD042S1T	A4-57	A4-89	A4-57	A4-89		●	
MSMD042S31N	A4-105	A4-108	A4-105	A4-108		▲	
MSMD042S32N	A4-105	A4-108	A4-105	A4-108		▲	
MSMD042S33N	A4-105	A4-108	A4-105	A4-108		▲	
MSMD042S34N	A4-105	A4-108	A4-105	A4-108		▲	
MSMD042S41N	A4-105	A4-108	A4-105	A4-108		▲	
MSMD042S42N	A4-105	A4-108	A4-105	A4-108		▲	
MSMD042S43N	A4-105	A4-108	A4-105	A4-108		▲	
MSMD042S44N	A4-105	A4-108	A4-105	A4-108		▲	
MSMD082P1A	A4-57	A4-89	A4-57	A4-89		●	
MSMD082P1B	A4-57	A4-89	A4-57	A4-89		●	
MSMD082P1S	A4-57	A4-89	A4-57	A4-89		●	
MSMD082P1T	A4-57	A4-89	A4-57	A4-89		●	
MSMD082P31N	A4-105	A4-108	A4-105	A4-108		●	
MSMD082P32N	A4-105	A4-108	A4-105	A4-108		●	
MSMD082P33N	A4-105	A4-108	A4-105	A4-108		▲	
MSMD082P34N	A4-105	A4-108	A4-105	A4-108		▲	
MSMD082P41N	A4-105	A4-108	A4-105	A4-108		▲	
MSMD082P42N	A4-105	A4-108	A4-105	A4-108		▲	
MSMD082P43N	A4-105	A4-108	A4-105	A4-108		▲	
MSMD082P44N	A4-105	A4-108	A4-105	A4-108		▲	
MSMD082S1A	A4-57	A4-89	A4-57	A4-89		●	
MSMD082S1B	A4-57	A4-89	A4-57	A4-89		●	
MSMD082S1S	A4-57	A4-89	A4-57	A4-89		▲	
MSMD082S1T	A4-57	A4-89	A4-57	A4-89		▲	
MSMD082S31N	A4-105	A4-108	A4-105	A4-108		▲	
MSMD082S32N	A4-105	A4-108	A4-105	A4-108		▲	
MSMD082S33N	A4-105	A4-108	A4-105	A4-108		▲	
MSMD082S34N	A4-105	A4-108	A4-105	A4-108		▲	
MSMD082S41N	A4-105	A4-108	A4-105	A4-108		▲	
MSMD082S42N	A4-105	A4-108	A4-105	A4-108		▲	
MSMD082S43N	A4-105	A4-108	A4-105	A4-108		▲	
MSMD082S44N	A4-105	A4-108	A4-105	A4-108		▲	
MSMD5AZP1A	A4-51,55	A4-88	A4-51,55	A4-88		●	
MSMD5AZP1B	A4-51,55	A4-88	A4-51,55	A4-88		●	

Index (Alphabetical order)

● : Standard stock item

▲ : Build order item

MSMD							
Part No.	A4		Carrying page A4P		E		Delivery
	Specifications	Dimension	Specifications	Dimension	Specifications	Dimension	
MSMD5AZP1S	A4-51,55	A4-88	A4-51,55	A4-88			●
MSMD5AZP1T	A4-51,55	A4-88	A4-51,55	A4-88			●
MSMD5AZS1A	A4-51,55	A4-88	A4-51,55	A4-88			●
MSMD5AZS1B	A4-51,55	A4-88	A4-51,55	A4-88			●
MSMD5AZS1S	A4-51,55	A4-88	A4-51,55	A4-88			●
MSMD5AZS1T	A4-51,55	A4-88	A4-51,55	A4-88			●

● : Standard stock item

▲ : Build order item

MUMA							
Part No.	A4		Carrying page A4P		E		Delivery
	Specifications	Dimension	Specifications	Dimension	Specifications	Dimension	
MUMA011P1S					E11	E15	●
MUMA011P1T					E11	E15	●
MUMA011P31N					E17	E19	▲
MUMA011P32N					E17	E19	▲
MUMA011P34N					E17	E19	▲
MUMA011P41N					E17	E19	▲
MUMA011P42N					E17	E19	▲
MUMA011P44N					E17	E19	▲
MUMA012P1S					E13	E15	●
MUMA012P1T					E13	E15	●
MUMA012P31N					E17	E19	▲
MUMA012P32N					E17	E19	▲
MUMA012P34N					E17	E19	▲
MUMA012P41N					E17	E19	▲
MUMA012P42N					E17	E19	▲
MUMA012P44N					E17	E19	▲
MUMA021P1S					E11	E15	●
MUMA021P1T					E11	E15	●
MUMA021P31N					E17	E19	▲
MUMA021P32N					E17	E19	▲
MUMA021P34N					E17	E19	▲
MUMA021P41N					E17	E19	▲
MUMA021P42N					E17	E19	▲
MUMA021P44N					E17	E19	▲
MUMA022P1S					E13	E15	●
MUMA022P1T					E13	E15	●
MUMA022P31N					E17	E19	▲
MUMA022P32N					E17	E19	▲
MUMA022P34N					E17	E19	▲
MUMA022P41N					E17	E19	▲
MUMA022P42N					E17	E19	▲
MUMA022P44N					E17	E19	▲
MUMA042P1S					E13	E15	●
MUMA042P1T					E13	E15	●
MUMA042P31N					E17	E19	▲
MUMA042P32N					E17	E19	▲

● : Standard stock item

▲ : Build order item

MUMA						
Part No.	Carrying page				E	Delivery
	Specifications	A4 Dimension	Specifications	A4P Dimension		
MUMA042P34N					E17	E19 ▲
MUMA042P41N					E17	E19 ▲
MUMA042P42N					E17	E19 ▲
MUMA042P44N					E17	E19 ▲
MUMA5AZP1S					E11,13	E15 ●
MUMA5AZP1T					E11,13	E15 ●

Sales Office

[Panasonic Sales Office of Motors]

(Jun. 25. 2006)

Country	Company Name	City	Address	TEL
				FAX
U.S.A.	Panasonic Industrial Company(PIC)	New Jersey	Two Panasonic Way Secaucus, New Jersey 07094 U.S.A.	1-201-348-5356 1-201-392-4888
		California	2033 Gateway Place, Suite 200 San Jose, CA 95110, U.S.A.	1-408-487-9536 1-408-436-8037
Europe	Panasonic Industrial Europe Ltd.(PIEL)	Bracknell	Panasonic House,Willoughby Road Brecknell, Berks, RG12 8FP,U.K.	44-1344-476-523 44-1344-476-579
	Panasonic Industrial Europe GmbH(PIEG)	Munich	Hans-Pinsel-Str. 2, 85540 Haar, Gemany	49-89-46159-230 49-89-46159-212
		Milano	Via Lucini 19, 20125 Milano, ITALY	39-02-6788-413 39-02-6788-207
	Barcelona	Avda. Josep Tarradellas. 20-30 Reception 5 Plantas4,5Y6 08029 Barcelona, SPAIN	34-93-494-9240 34-93-419-8931	
Taiwan	Panasonic Industrial Sales (Taiwan) Co., Ltd.(PIST)	Taipei	6F, 550, Sec.4, Chung Hsiao E.RD. Taipei, 110, TAIWAN, R.O.C	886-2-2757-1899 886-2-2757-1977
Singapore	Panasonic Industrial Singapore(PICS)	Singapore	300 Beach Road #16-01 The Concourse Singapore 199555	65-6390-8384 65-6390-3834
China	Panasonic Shun Hing Industrial Sales (Hong kong) Co., Ltd.	Hong kong	Level 33, Office Tower, Langham Place, 8 Argyle Street, Mongkok, Kin.,Hong Kong	852-2529-7322 852-2598-9743
	Panasonic Industrial (China) Co.,Ltd. (PICH)	Shanghai	Floor 5, China Insurance Building, 166 East Road LuJiaZui PuDong New District, Shanghai, China, 200120	86-21-6841-9651 86-21-6841-9249
India	Panasonic Industrial Asia Pte Ltd. (PIAI)	New Delhi	510, E-Block, International Trade Tower, Nehru Place, New Delhi	91-11-26292870 91-11-26292878

[Distributor]

Country	Company Name	City	Address	TEL
				FAX
Korea	YOUNG IL Electric Co.,Ltd.	Seoul	982-4, 3 Dong, Shiheung, Keumcheon-Ku, Seoul	82-2-805-2471 82-2-805-2475
	Soonhan Engineering Co.,Ltd.	Sungnam	333-11, Sangdaewon-Dong, Jungwon-Ku, Sungnam-Si, Gyunggi-Do, Korea	82-31-737-9188 82-31-732-9188
	Zeus Co.,Ltd.	Osan	163-1, Busan-Dong, Osan-City, Kyunggi-Do, Korea	82-31-377-9500 82-31-378-8660

Cautions for Proper Use

- This product is intended to be used with a general industrial product, but not designed or manufactured to be used in a machine or system that may cause personal death when it is failed.
- Install a safety equipments or apparatus in your application, when a serious accident or loss of property is expected due to the failure of this product.
- Consult us if the application of this product is under such special conditions and environments as nuclear energy control, aerospace, transportation, medical equipment, various safety equipments or equipments which require a least air contamination.
- We have been making the best effort to ensure the highest quality of the products, however, application of exceptionally larger external noise disturbance and static electricity, or failure in input power, wiring and components may result in unexpected action. It is highly recommended that you make a fail-safe design and secure the safety in the operative range.
- If the motor shaft is not electrically grounded, it may cause an electrolytic corrosion to the bearing, depending on the condition of the machine and its mounting environment, and may result in the bearing noise. Checking and verification by customer is required.
- Failure of this product depending on its content, may generate smoke of about one cigarette. Take this into consideration when the application of the machine is clean room related.
- Please be careful when using in an environment with high concentrations of sulphur or sulphuric gases, as sulphuration can lead to disconnection from the chip resistor or a poor contact connection.
- Take care to avoid inputting a supply voltage which significantly exceeds the rated range to the power supply of this product. Failure to heed this caution may result in damage to the internal parts, causing smoking and/or a fire and other trouble.
- Read and observe the instruction manual without fail for proper usage of the products.

Repair

Consult to the dealer from whom you have purchased this product for details of repair work.
When the product is incorporated to the machine you have purchased, consult to the machine manufacturer or its dealer.

URL

Electric data of this product (Instruction Manual, CAD data) can be download from the following web site;
<http://industrial.panasonic.com/ww/i_e/25000/motor_fa_e/motor_fa_e.html>

Contact to :

Motor Company Matsushita Electric Industrial Co., Ltd.

1-1 Morofuku 7-chome, Daito, Osaka 574-0044, Japan
Tel : +81-72-871-1212
Fax: +81-72-870-3151



ISO14001 Certificate division
CERTIFICATE OF APPROVAL ISO14001



ISO9001 Certificate division
CERTIFICATE OF APPROVAL ISO9001

The contents of this catalog apply
to the products as of Jun. 1, 2006.

- Printed colors may be slightly different from the actual products.
- Specifications and design of the products are subject to change without notice for the product improvement.
- For environmental protection, this document is made of recycled paper, and printed with soybean oil ink.

